

Robinsons Reach Rosette

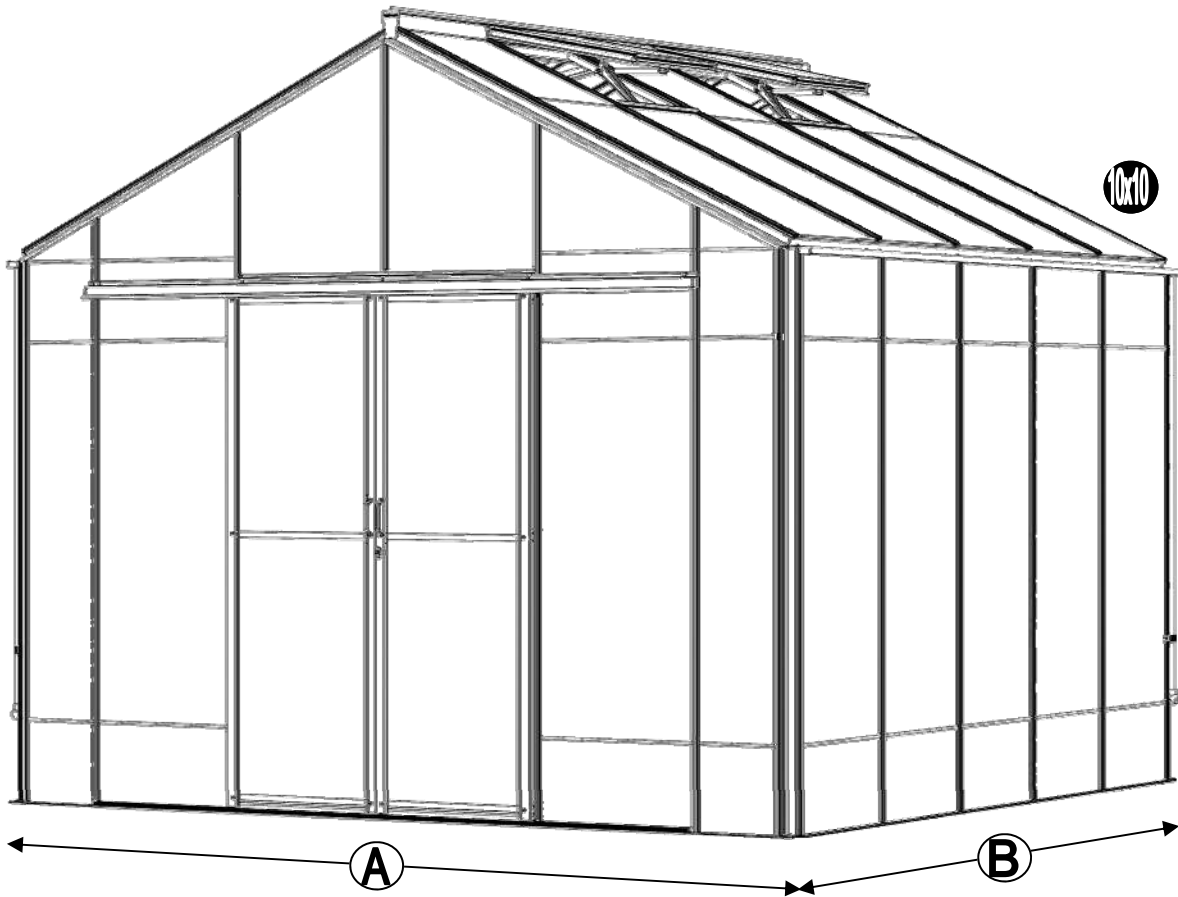

NOMINAL SIZE	A (mm)	B (mm)
10 x 6	3260	2012
10 x 8		2632
10 x 10		3252
10 x 12		3872

NOMINAL SIZE	A (mm)	B (mm)
6ft extension	-	1860
8ft extension		2480
10ft extension		3100
12ft extension		3720

Bedankt voor de aankoop van uw nieuwe Robinsons tuinkas. Wij raden u aan de instructies te lezen en alle veiligheidsinformatie door te nemen voordat u begint met de montage.

Deze handleiding is onderverdeeld in secties die gemarkeerd worden door een wit nummer/letter op een zwarte achtergrond in de rechterhoek van de meeste pagina's (zie de volgende pagina voor meer informatie); onderdelenlijst, **B**-base/fundering, **V**-voorbereiding, **1**-zijwanden, **2**-voorwand, **3**-achterwand, **4**-de wanden aan elkaar bevestigen, **5**-dak, **6**-dakraam, **7**-deur, **8**-beglazing, **9**-dakraambevestiging, **10**-deurbevestiging, **11**-verankering, **12**-optionele lamellenramen, **13**-optionele opbergplanken, **14**-optionele werktafel, **15**-afwerking. Indien u contact met ons moet opnemen voor hulp, verwijst dan naar de betreffende sectie(s). Als uw tuinkas langer is dan 3872 mm, dan komt er een extensie aan uw kas. Raadpleeg dan ook de aparte uitbreidingshandleiding.

Veiligheidswaarschuwing

- Glas en aluminium kan letsel veroorzaken. Zorg ervoor dat u een **veiligheidsbril, handschoenen, veiligheidshelm** en **geschikt schoeisel** draagt tijdens het monteren en beglazen van de tuinkas.
- Denk eraan dat glas breekbaar is en dat u er voorzichtig mee om moet gaan. Ruim gebroken glas altijd onmiddellijk op en gooi het weg.
- Zet de kas niet in elkaar bij harde wind; verifieer de weersvoorspelling voor de periode waarop de tuinkas wordt gemonteerd.
- Om veiligheidsredenen en om de montage te vergemakkelijken, raden we u aan om de kas door minimaal twee personen te laten monteren.
- Verwijder altijd de sneeuw dat op het dak van de kas ligt om overbelasting van de kas te voorkomen.
- Bij harde wind of storm is het gevaarlijk om in de kas aanwezig te zijn.
- Uw kas is geleverd met gehard glas. De zijde waar u doorheen kijkt is extreem sterk, maar de randen zijn erg gevoelig. Zet daarom nooit het glas op de grond zonder klosjes eronder.

Voorbereiding van de werkplek

- Een betonnen of betegelde fundering biedt de meest solide basis voor uw tuinkas.
- **BELANGRIJK:** Zet uw de kas pas vast aan de grond als deze volledig gemonteerd is, inclusief beglazing.
- Plaats uw kas niet onder bomen of op andere kwetsbare locaties.
- Probeer een beschutte locatie te kiezen, bijvoorbeeld naast een haag of tuinhek, om het risico op windschade te minimaliseren.

Aanvullende opmerkingen

- Houd er rekening mee dat de montage van uw kas tijdrovend werk is. Het is verstandig om de montage over twee of meer dagen te verspreiden. We raden u aan om de tuinkas niet gedeeltelijk beglaasd achter te laten om windschade te voorkomen.
- Het is handig om een grote, schone en overzichtelijke werkplek voor te bereiden. Een garagevloer of vlak grasveld is ideaal.
- Het verankeren van uw kas is de laatste fase (na het beglazen).
- Eenmaal geïnstalleerd heeft uw kas weinig onderhoud nodig, maar om ervoor te zorgen dat uw deur(en) soepel blijven lopen, kunt u WD40 aanbrengen op de deurwielen en de deurgeleiders.

Garantie

- Uw nieuwe Robinsons kas heeft 10 jaar garantie tegen fabrieksfouten aan het frame. Dit omvat geen glas, bewegende onderdelen en schade door ongevallen of windschade.

Robinsons afdeklijsten:

Bij een Robinsons tuinkas bestaan de afdeklijsten uit twee delen. De onderste zwarte kunststof afdeklijsten worden op het frame geschroefd. Hierdoor wordt het glas op het rubber profiel wordt gedrukt. Daarna moeten de bovenste aluminium afdeklijsten worden aangebracht. Op deze manier worden de kopjes van de RVS schroeven afgedekt. Indien u moeite heeft met het aandrukken van de afdeklijsten, raden wij u aan om een rubberen hamer of een houten blok en hamer te gebruiken. Een korte, scherpe tik op de afdeklijst aan één kant is alles wat nodig is om deze vast te zetten.

Sommige aluminium afdeklijsten hebben aan één kant een gat dat wordt gebruikt om de onderdelen aan op te hangen tijdens het poedercoaten. Als u wilt, kunt u het gat gebruiken om te voorkomen dat de afdeklijsten in het dak schuiven.

DRAAG EEN VEILIGHEIDSBRIL EN HANDSCHOENEN OM LETSEL TE VOORKOMEN!



ICOON	BETEKENIS
	BUITENAANZICHT
	BINNENAANZICHT
	DENK
	DEZE SECTIE HEEFT BETREKKING OP EEN ANDERE (bijvoorbeeld 1 en 5)
	CORRECT
	<u>NIET</u> VASTZETTEN!
	DRAAIEN OM TE VERGRENDELEN
	AANDRAAIEN
	DRUKKEN EN VASTHOUDEN
	KNIP OP LENGTE

SECTIE NUMMER	TITEL	MONTAGE SAMENVATTING: BELANGRIJKE INFORMATIE / OVERWEGINGEN
	ONDERDELEN- LIJST	Monteer eerst alle wanden separaat op een vlakke schone ondergrond. Sorteert de onderdelen en leg ze in de vorm zoals op de tekening is aangegeven. Pak niet alle bundels tegelijk uit. Zorg dat u georganiseerd te werk gaat. Onderdelen kunnen worden geïdentificeerd aan de hand van hun profielfoto's en opgegeven lengtes.
B	BASE FUNDERING	Afmetingen en aanbevelingen voor de fundering. Zorg ervoor dat uw fundering vlak en waterpas is. Iedere oneffenheid komt terug in het gebouw bij het beglazen!
V	VOORBEREIDING	Benodigde gereedschappen o.a.: 2x steeksleutel 10mm, stanley-mes, kitspuit, kruiskopschroevendraaier, schroefmachine (niet voor bouten/moeren!), waterpas, veiligheidsbril, veiligheidshelm en handschoenen.
1	ZIJWAND(EN)	Neem het tuinkasprofiel met de rubbers erin en de diagonale schoren, gebruik 10mm bouten om ze aan de goot te bevestigen en gebruik 15mm bouten aan de dorpels (let op hoe de kop van de bouten in elk profiel schuift tijdens de constructie).
2	VOORWAND	Zorg er opnieuw voor dat het frame is gerubberd en volg de instructies om het frame van de kas in elkaar te zetten. Zorg ervoor dat u de extra bouten heeft aangebracht die u in sectie 4, 5 en 10 heeft moeten gebruiken. Voor de dak- en zijhoekbalken is niet voor elke sleuf rubber nodig, tenzij u een (optionele) scheidingswand heeft (zie aparte handleiding en sectie V).
3	ACHTERWAND	
4	DE WANDEN AAN ELKAAR BEVESTIGEN	Neem de zijwand(en) (1), de voorwand (2) en de achterwand (3) en voeg ze samen op de fundering.
5	DAK	Bevestig de nok en plaats vervolgens de gerubberde dakprofielen. Zorg ervoor dat de deze volledig tegen de nok en de goot aanliggen. Er worden buisvormige beugels meegeleverd voor extra stevigheid. Deze kunnen nu of later worden gemonteerd met (hamerkop)bouten.
6a	DAKRAAM	Gebruik silicone om de glasplaat in de sponning vast te zetten. Ook zonder silicone blijft het dakraam in het profielwerk zitten. Soms komen de gaatjes niet 100% overeen bij het monteren van het dakraam. U kunt deze dan eenvoudig opboren met een 7mm boortje zodat de onderdelen alsnog in elkaar passen.
6b	RAAMDORPEL	Plaats de raamdorpel nadat u de glasplaat heeft geplaatst die eronder komt. Op die manier heeft u direct de juiste plek. De raamdorpel schuift iets over het glas heen.
7	DEUR	Monteer de deur op aan de hand van de instructies. Leg de deur aan de kant klaar voor bevestiging in sectie (10).
8	BEGLAZING	Voor u het glas plaatst kunt u de zwarte schroeflijsten alvast rondom de kas klaarzetten. In sommige gevallen moeten de zwarte lijsten nog iets worden ingekort. Ook is het belangrijk dat de gaatjes waar de RVS schroeven doorheen gaan ook op het uiteinde zitten. Neem een 6.5mm boortje om eventueel nog een gaatje bij te boren. Leg eerst de glasplaat linksachter op het dak, dan linksachter in de zijwand en in de kopgevel linksachter. Op deze manier kunt u zien of het frame helemaal recht en haaks staat. Meestal moet er nog een en ander afgesteld worden voor u het glas in de kas kunt monteren. Na linksachter kunt u rechtsvoor erin zetten. Hierdoor weet u (zeker bij grotere kassen) dat alle glas er netjes in komt. Helemaal perfect bestaat bijna niet. In de ondergrond zit altijd wel een kleine oneffenheid.
9	DAKRAAM- BEVESTIGING	Neem het voorgemonteerde dakraam en schuif deze aan de voor- of achterzijde in de nok. Vergeet niet om onderdeel D220 voor en achter het raam te plaatsen zodat het raam op zijn plek blijft.
10	DEUR- BEVESTIGING	Gebruik de boutjes die u al heeft ingevoerd bij stap 2 om de deurgeleider te bevestigen. De onderdorpel moet in elkaar geklikt worden. Zorg dat de ondergrond hier 100% recht en vlak is.
11	VERANKERING	Nu de kas volledig is afgemonteerd en het glas in de sponningen is geplaatst kunt u de kas verankeren aan de ondergrond.
12	OPTIONELE LAMELLENRAMEN	De lamellenramen plaatst u tijdens het beglazen met een zwart H-profiel eronder en erboven.
13	OPTIONELE OPBERG- PLANKEN	Robinsons opbergplanken en werktafels zijn een efficiënte en integrale oplossing. Let op dat het monteren tijdrovend is. U kunt bij het voorbereiden van de kas boutjes en moertjes in de profielen schuiven zodat u het gebruik van hamerkopbouten voorkomt. Met de vierkante boutjes is het monteren een stuk gemakkelijker. Neem rustig de tijd om de tafel en plank te installeren.
14	OPTIONELE WERKTAFEL	
15	AFWERKING	Als laatste kunt u de regenpijpen monteren. Kit e.e.a. goed af om lekkage te voorkomen.

Section Ref	Part No.	Section	Size (mm)	10 6	10 8	10 10	10 12
-------------	----------	---------	-----------	------	------	-------	-------

1	D036		1890	2			
	D037		2510		2		
	D050		3130			2	
	D040		3750				2
	D042		1897	2			
	D014		2517		2		
	D015		3137			2	
	D016		3757				2
	D782		2071	4			
	D051		1976	4	6	8	10
RUBBER		1000 (1m)	16	24	32	40	
D174		N/A	4	4	8	8	

2 + 3	D038		3140		2		
	D780		1976		4		
	D055		2422		4		
	D056		2126		4		
	D744		2718		1		
	D109		3140		2		
	D719		2186		4		
	D854L		1744		2		
	D854R		1744		2		

Section Ref	Part No.	Section	Size (mm)	10 6	10 8	10 10	10 12
-------------	----------	---------	-----------	------	------	-------	-------

2 + 3	D111		N/A		2		
	RUBBER		1000 (1m)		66		
	D174		N/A		8		

5	D044		1897	1			
	D001		2517		1		
	D002		3137			1	
	D003		3757				1
	D065		1744	4	6	8	10
	D126		445	0	2	4	6
	D128		1015	0	1	2	2
	RUBBER		1000 (1m)	14	21	28	35

6	D866		639	1	2	3	4
	D863L		613	1	2	3	4
	D863R		613	1	2	3	4
	D862		593	1	2	3	4
	D079 PLUS FLUFF		590	1	2	3	4
	D114		N/A	2	4	6	8
	D220 PLUS FS6060 SCREW		N/A	2	4	6	8
	D205		N/A	2	4	6	8

Section Ref	Part No.	Section	Size (mm)	10 6	10 8	10 10	10 12
-------------	----------	---------	-----------	------	------	-------	-------

7	D090 + D347 lock = D301		1824			1	
	D092 + D156 strike = D303		1824			1	
	D093		1824			1	
	D094		1824			1	
	D096 + D217 wheel = D307		611			2	
	D095		611			2	
	D097		611			2	
	D232		905			4	
	D233		797			4	
	P053		N/A			2	
	D225		610			2	
	D840B		4000			1	

HOOFDFRAME HOEVEELHEDEN DAKRAMEN/DEUREN ECT. APART		10mm	34	40	46	52
		15mm	48	50	52	54
		m6	82	90	98	106

Section Ref	Part No.	Section	Size (mm)	10 6	10 8	10 10	10 12
-------------	----------	---------	-----------	------	------	-------	-------

8	3	D746		2718			1	
	2	D748		787			1	
	1	D816		1976	4	6	8	10
	2/3	D818		2126			4	
	3	D822		2422			2	
	2	D823		516			2	
	5	D870		601	4	6	8	10
	5	D876		1152	4	6	8	10
	1/2/3	D781			1976			8
	2	D814			1883			2
	5	D871			601			4
	5	D877			1152			4
10	3	D747		2718			1	
	2	D749		787			1	
	5	D811		1754	8	10	12	14
	1/2/3	D828		1978	12	14	16	18
	2/3	D829		2128			4	
	3	D832		2424			2	
	2	D833		518			2	
	2	D836		1883			2	

10	D745		812			1
	D865		1210			1
	D861		2450			1
	D088		1207			1
	D086		2510			1
	D085		2510			1
	D153		198			2
	D163		90			2
	D150		N/A			1
	D154		N/A			2

DE AFMETINGEN HIERONDER ZIJN DE EXACTE BUITENMATEN VAN DE FUNDERING VOOR HET ROBINSONS ASSORTIMENT.

We kunnen niet genoeg benadrukken hoe belangrijk het is om een goede fundering te hebben voor uw Robinsons tuinkas.

Het is van essentieel belang dat de fundering VLAK, GELIJK, HAAKS en STEVIG genoeg is om het gewicht van de kas inclusief het glas te dragen.

Zorg ervoor dat er voldoende ruimte is rondom de fundering voor zowel het plaatsen van het glas als eventueel onderhoud/schoonmaak.

Een fundering van stoeptegels die iets groter is dan de kas is de ideale oplossing en heeft onze voorkeur.

Een fundering gemaakt met opsluitbanden is ook geschikt. Houd dan wel rekening met de breedte van de opsluitbanden. Bij de voordeur kunnen twee opsluitbanden naast elkaar nodig zijn om de deurgeleider rails op de bodem goed te ondersteunen.

BELANGRIJK: Veranker uw kas niet voordat deze volledig is gemonteerd, inclusief beglazing, tenzij u 100% zeker weet dat uw fundering haaks en waterpas is. Anders past het glas niet goed.

BELANGRIJK: Als er iets over de nok van een aangebouwd gebouw uitsteekt (zoals een dakoverstek), zorg er dan voor dat het de werking van de dakramen niet belemmert.

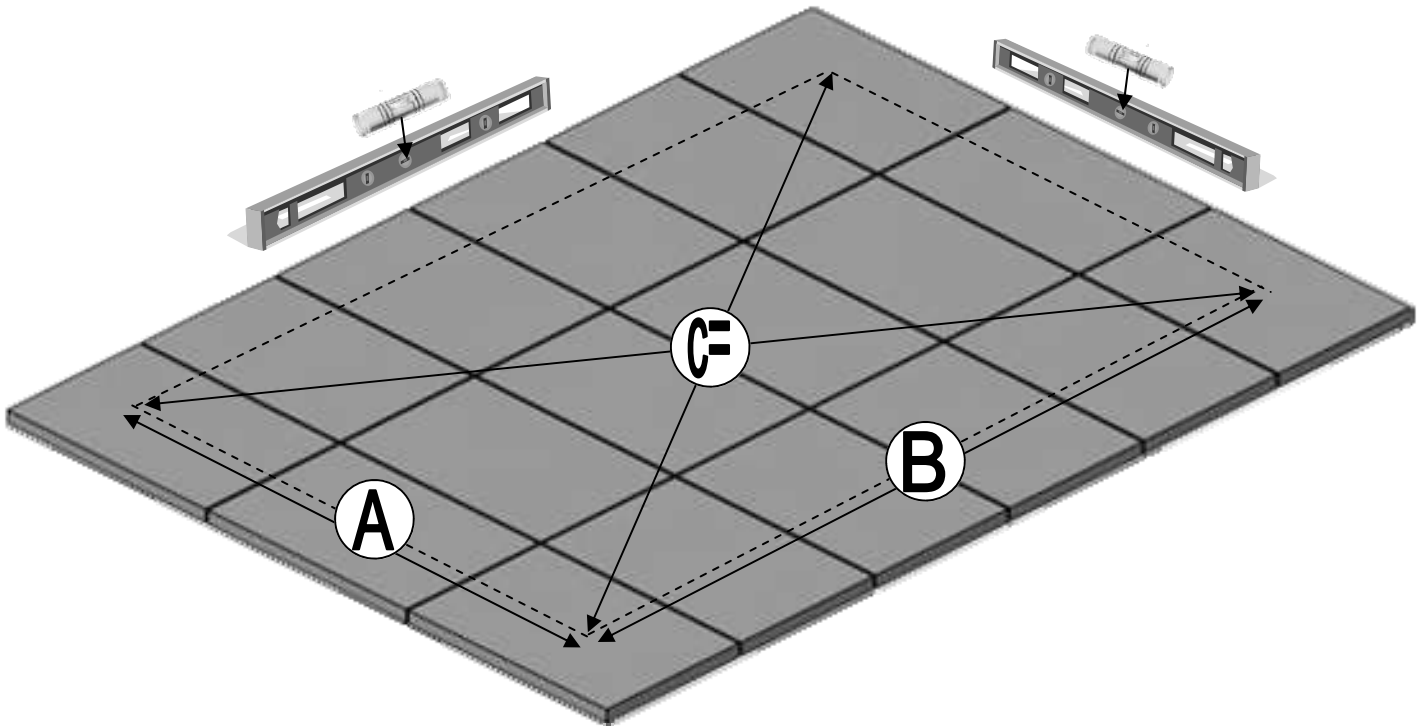

BUITENAFMETINGEN (MM)

De maten in mm hieronder zijn de buitenmaten

MODEL	A (mm) WIDTH	B (mm) LENGTH	C (mm) DIAGONAL	
REACH ROSETTE	10 x 6	2012	3787	
	10 x 8	3260	2632	4150
	10 x 10	3252	4568	
	10 x 12	3872	5028	
EXTENSIONS	6ft ext.	-	1860	-
	8ft ext.	-	2480	-
	10ft ext.	-	3100	-
	12ft ext.	-	3720	-

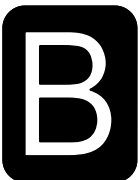

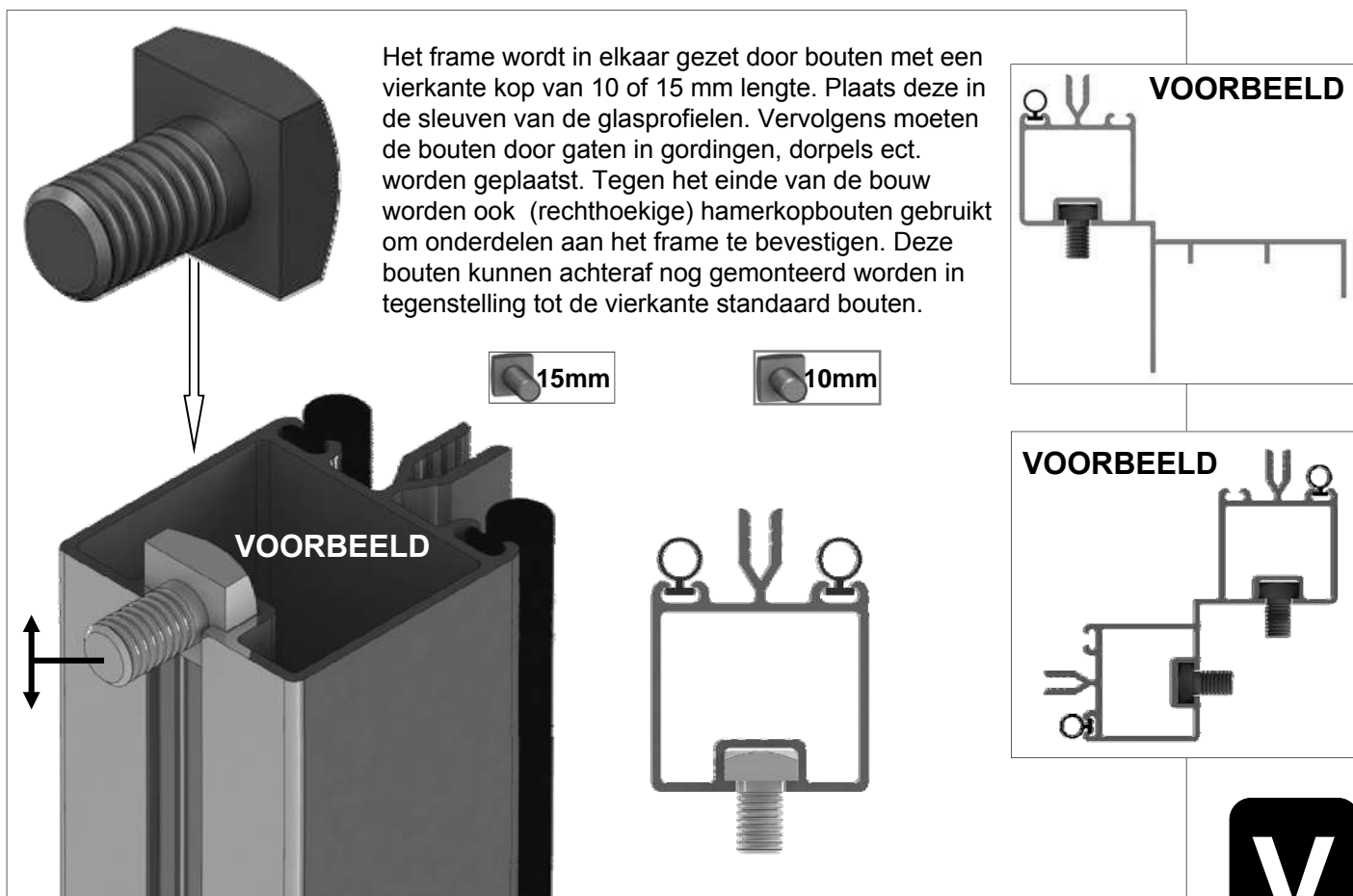
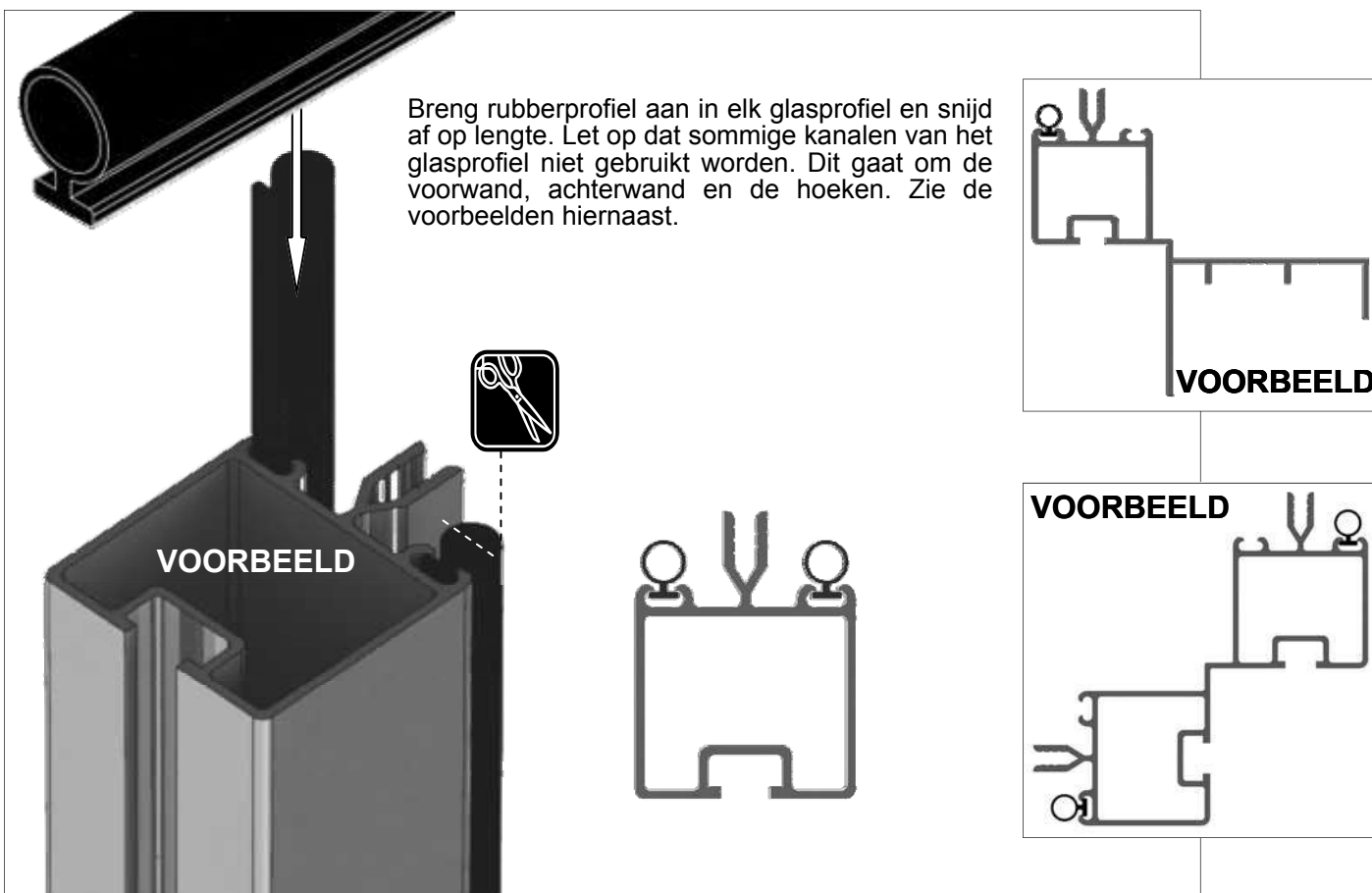

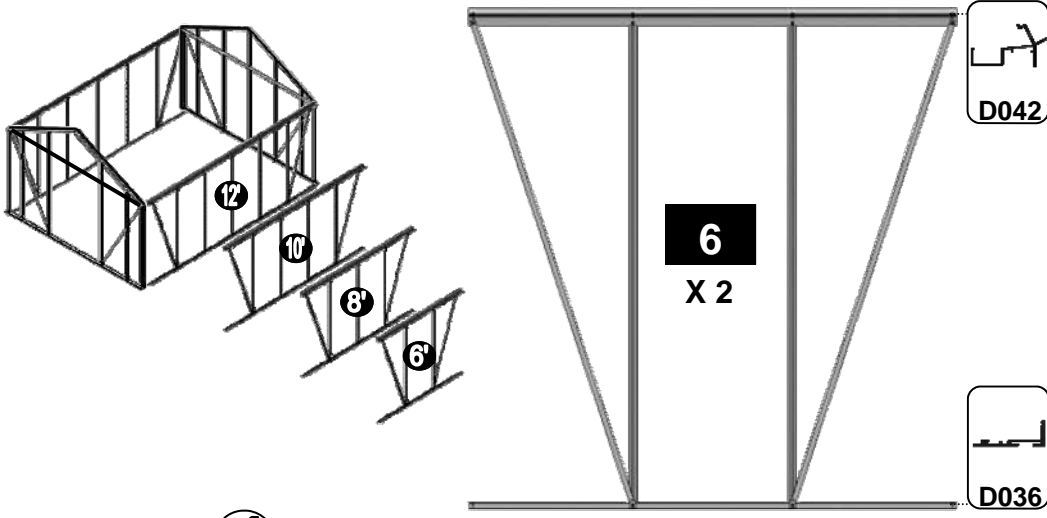

HIGH SIDE 6 X 2		
Part No	mm	Quantity
D042	1897	2
D036	1890	2
D051	1976	4
D782	2071	4
D174		4
M6-10mm		4
M6-15mm		8
M6-NUT		12
Rubber	1000	16

VOORBEELD ①

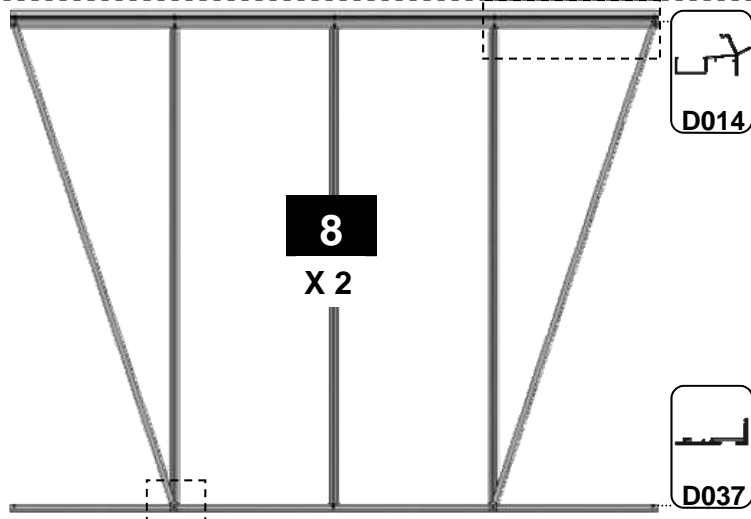

HIGH SIDE 8 X 2		
Part No	mm	Quantity
D014	2517	2
D037	2510	2
D051	1976	6
D782	2071	4
D174		4
M6-10mm		6
M6-15mm		10
M6-NUT		16
Rubber	1000	24

VOORBEELD ②

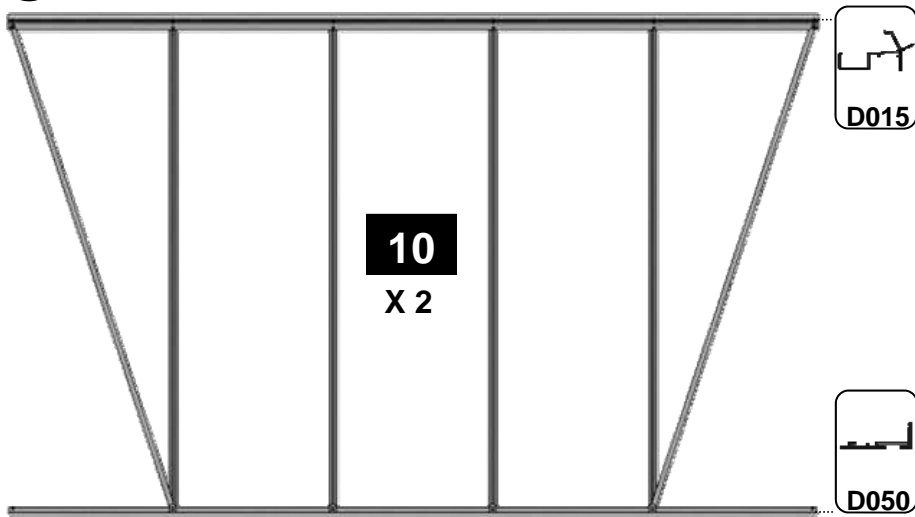

HIGH SIDE 10X 2		
Part No	mm	Quantity
D015	3137	2
D050	3130	2
D051	1976	8
D782	2071	4
D174		8
M6-10mm		8
M6-15mm		12
M6-NUT		20
Rubber	1000	32

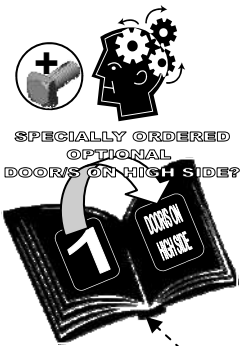

SPECIALLY ORDERED
OPTIONAL
DOORS ON HIGH SIDE?

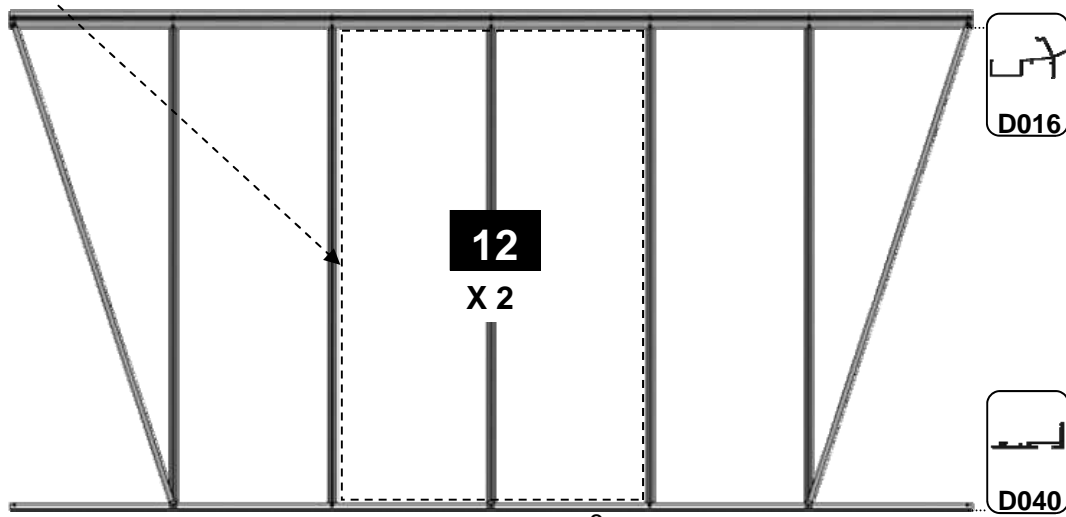

HIGH SIDE 12X 2		
Part No	mm	Quantity
D016	3757	2
D040	3750	2
D051	1976	10
D782	2071	4
D174		8
M6-10mm		10
M6-15mm		14
M6-NUT		24
Rubber	1000	40



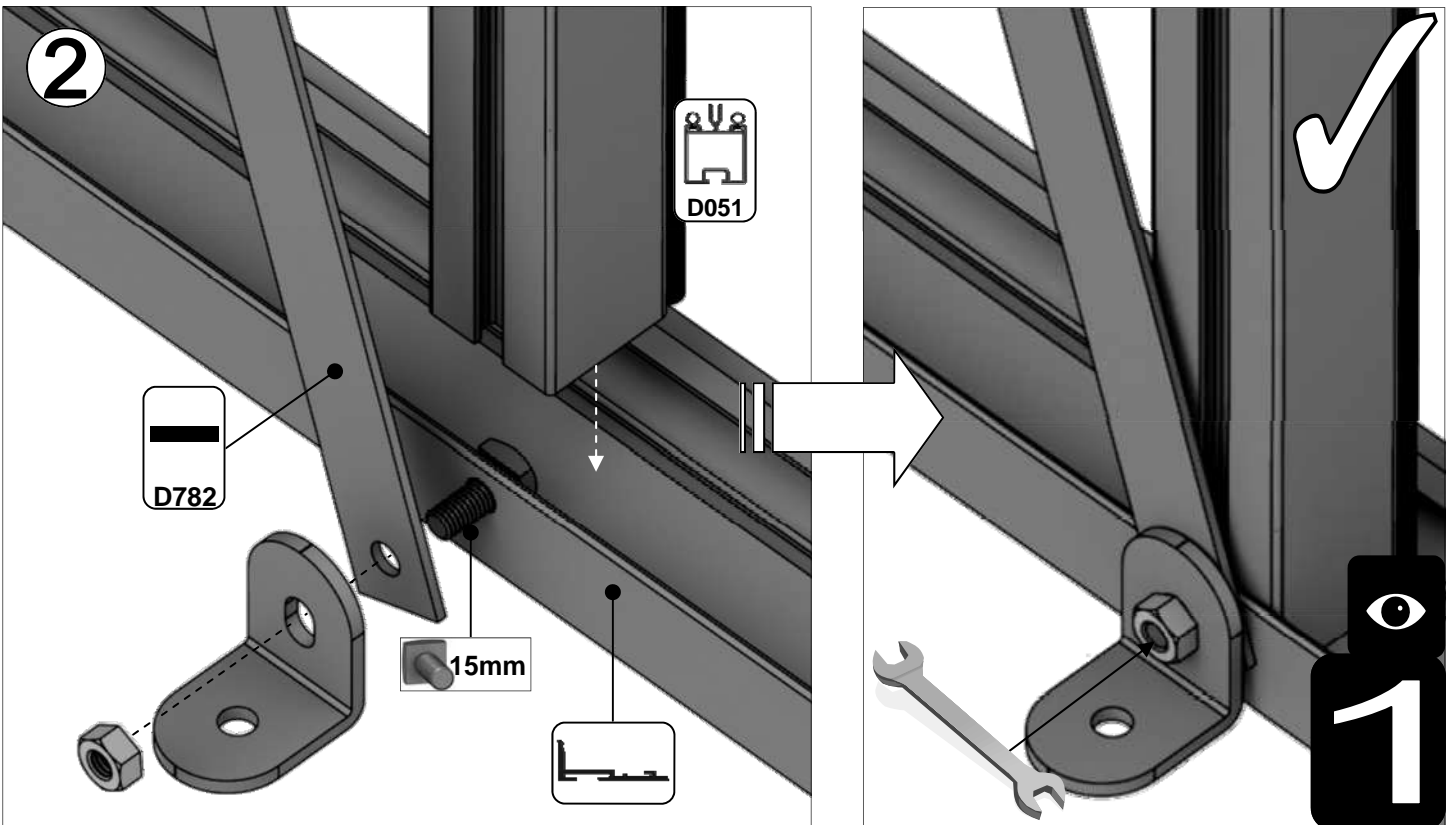
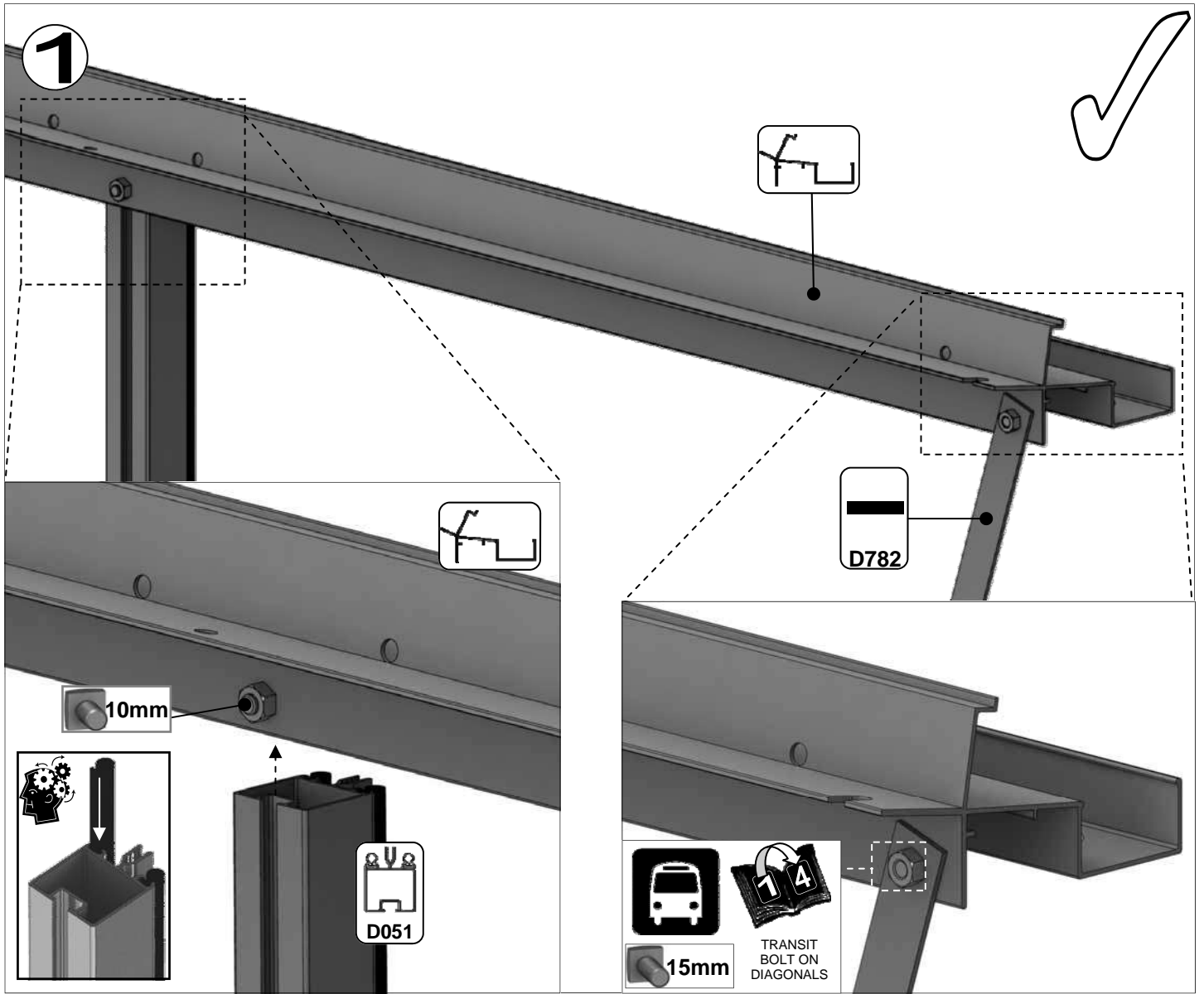

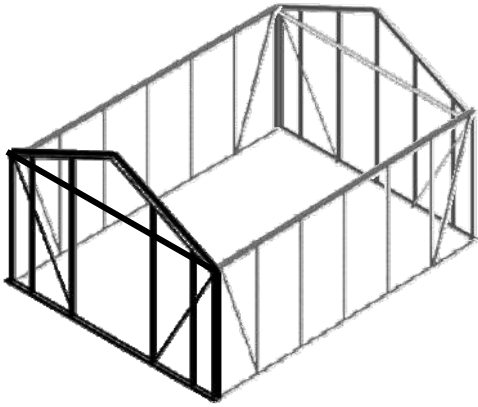

Part No	mm	Quantity
D038	3140	1
D055	2422	2
D056	2126	2
D109	3140	1
D719	2186	2
D780	1976	2
D854L	1744	1
D854R	1744	1

Part No	mm	Quantity
D111		1
D174		4
D227		30m
M6X10		10
M6X15		20
M6NUT		30

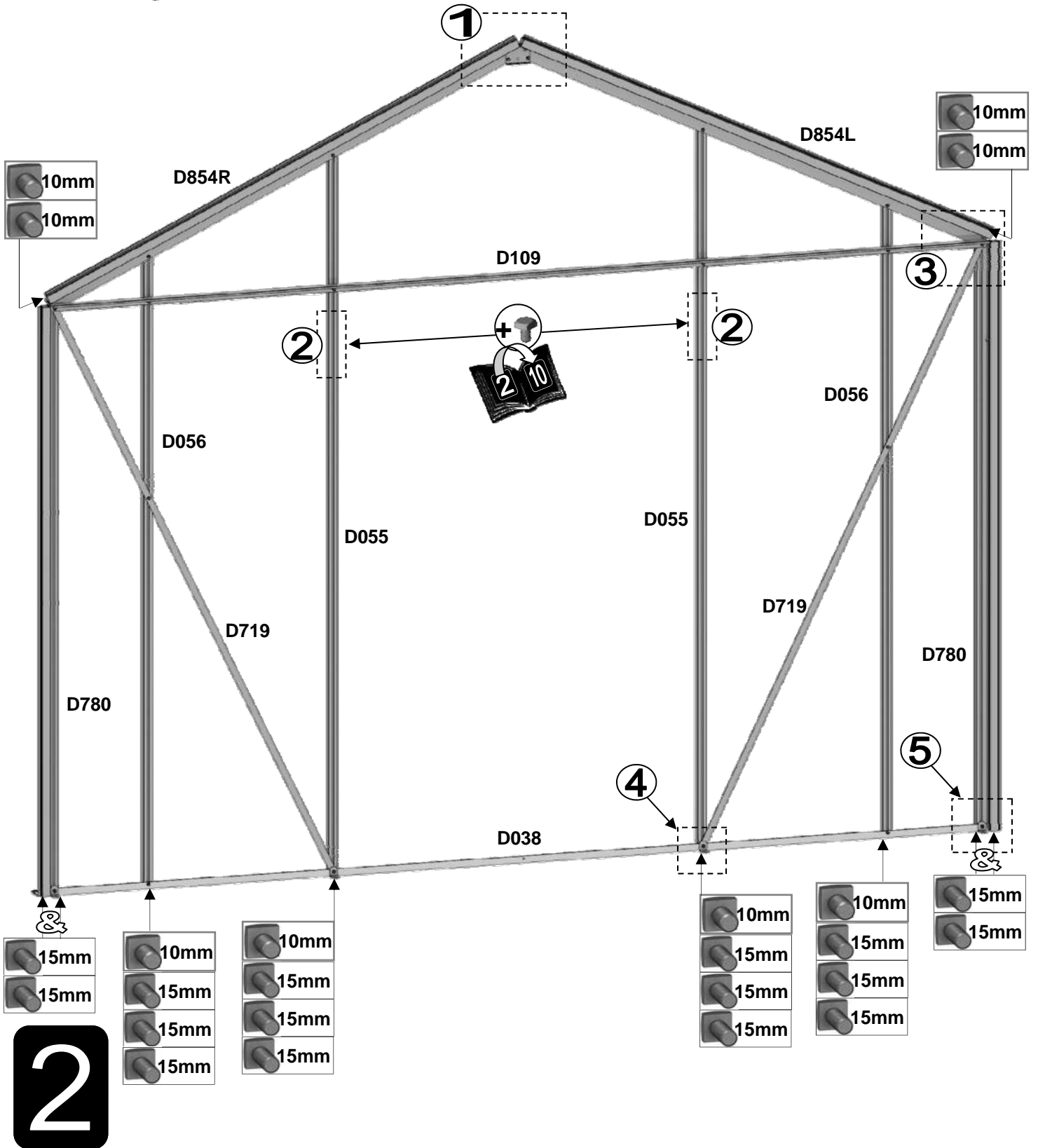

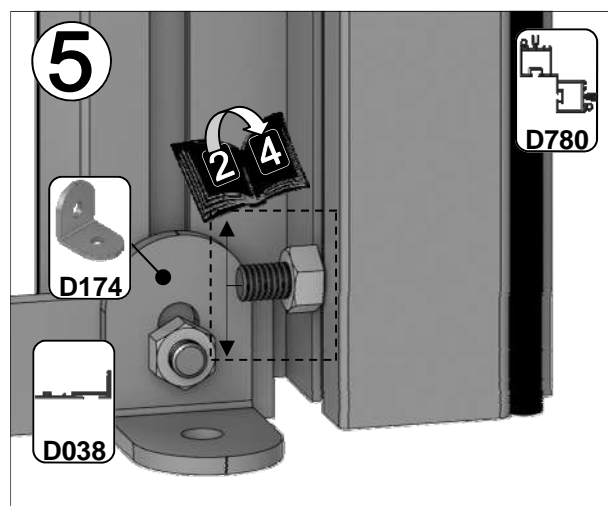
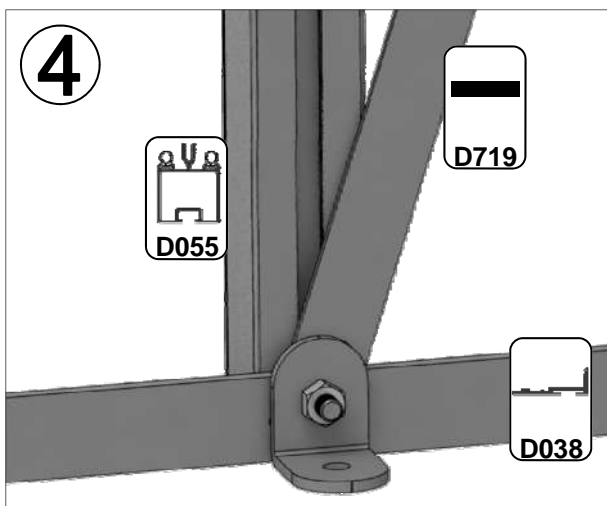
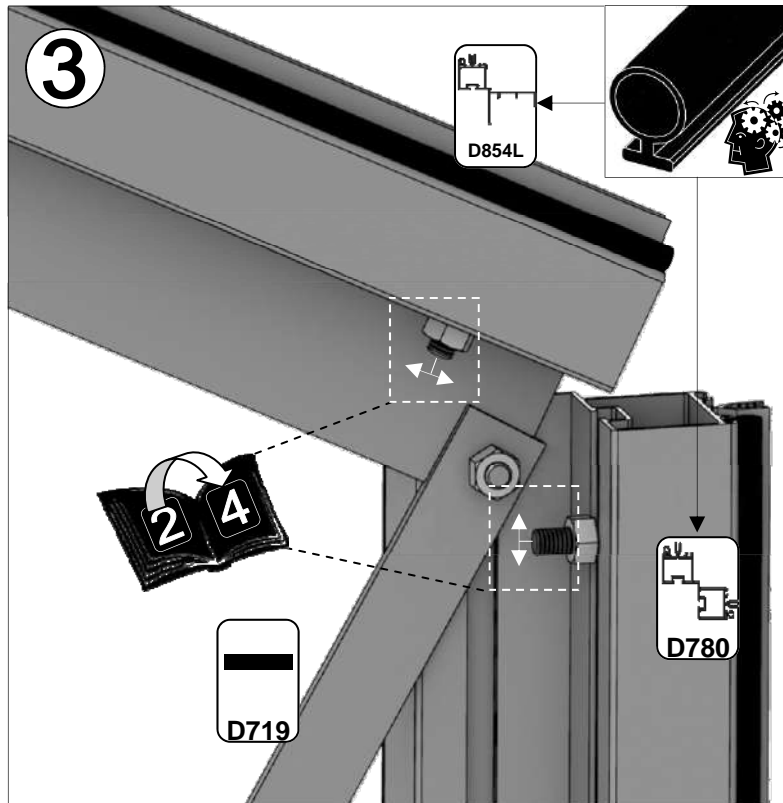
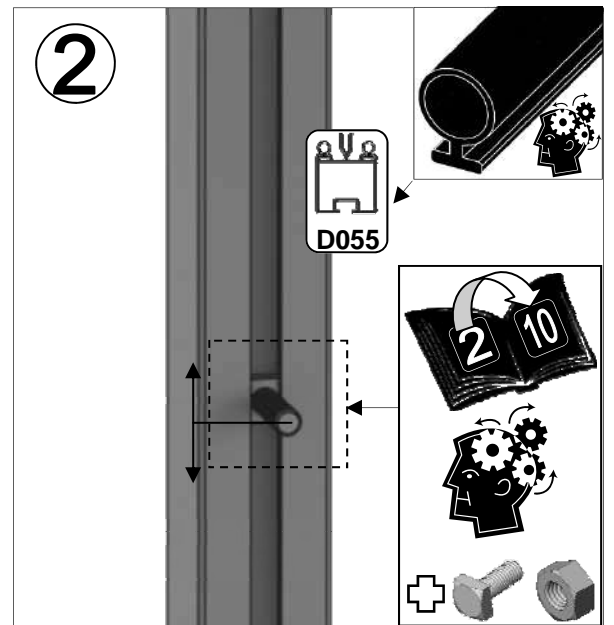
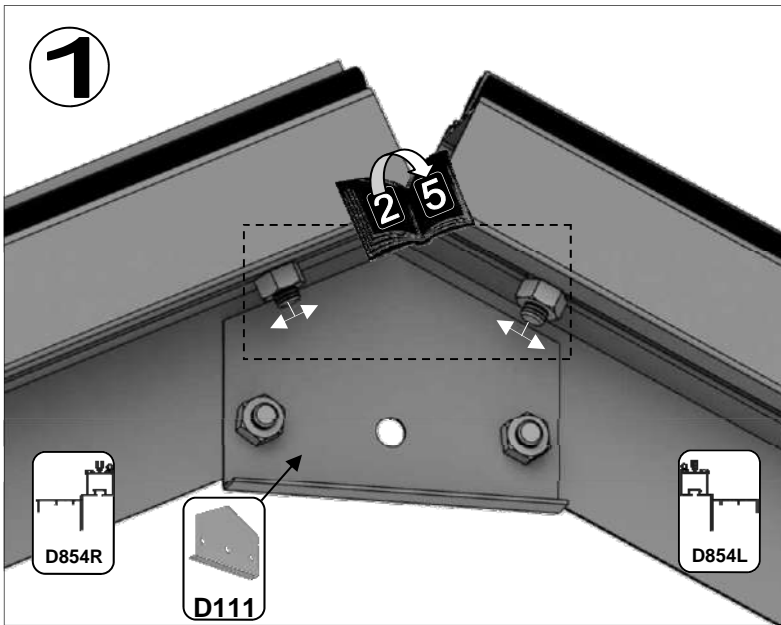

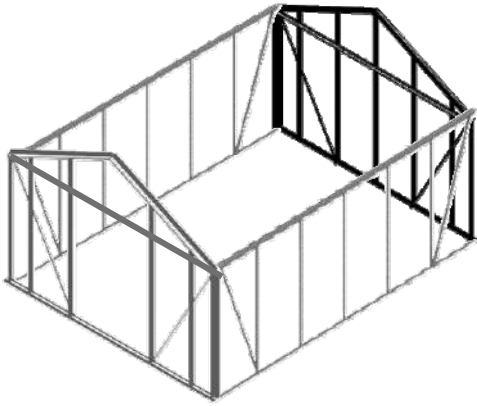

Part No	mm	Quantity
D038	3140	1
D055	2422	2
D056	2126	2
D109	3140	1
D719	2186	2
D744	2718	1
D780	1976	2
D854L	1744	1
D854R	1744	1

Part No	mm	Quantity
D111		1
D174		4
D227		36m
M6X10		11
M6X15		20
M6NUT		31

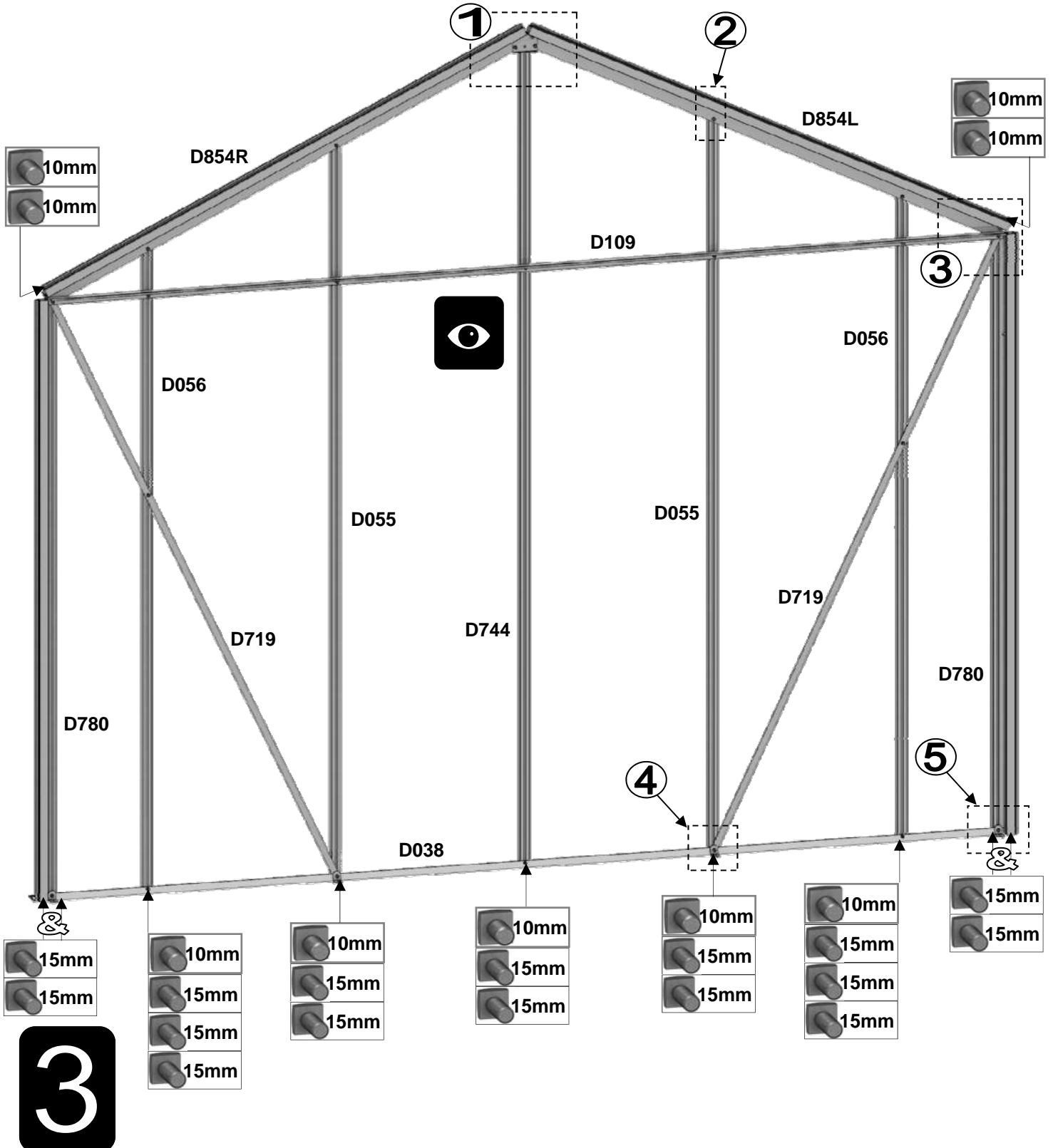

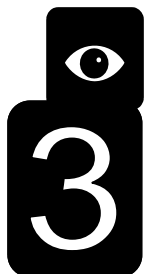
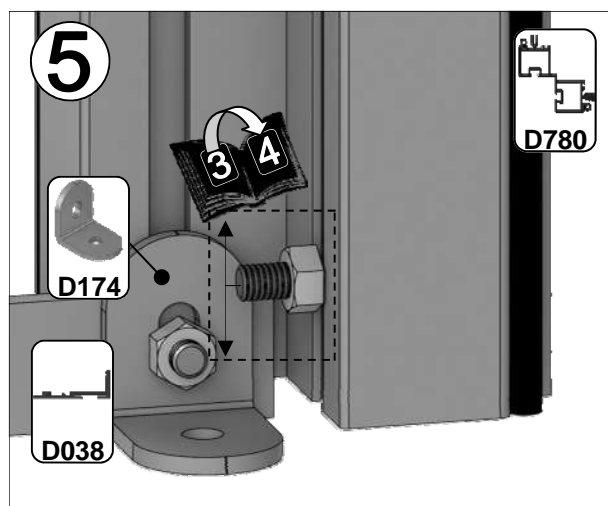
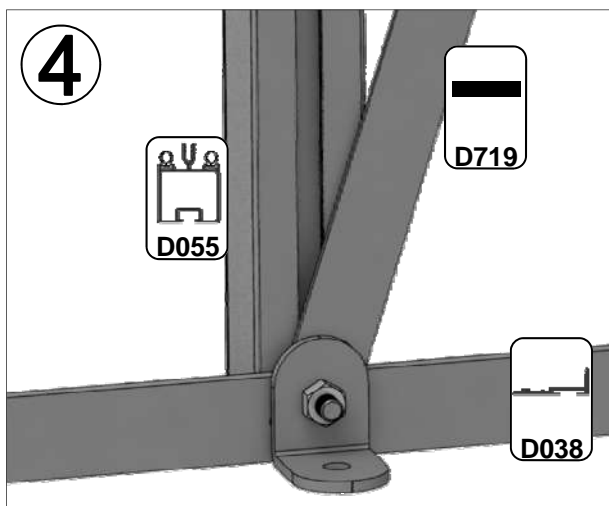
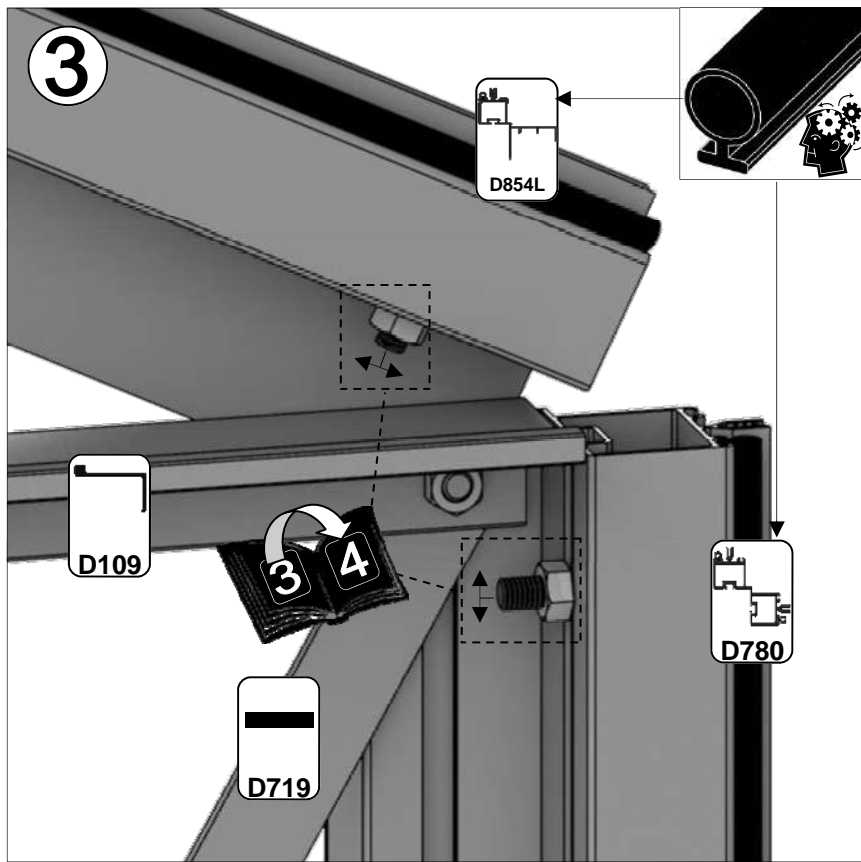
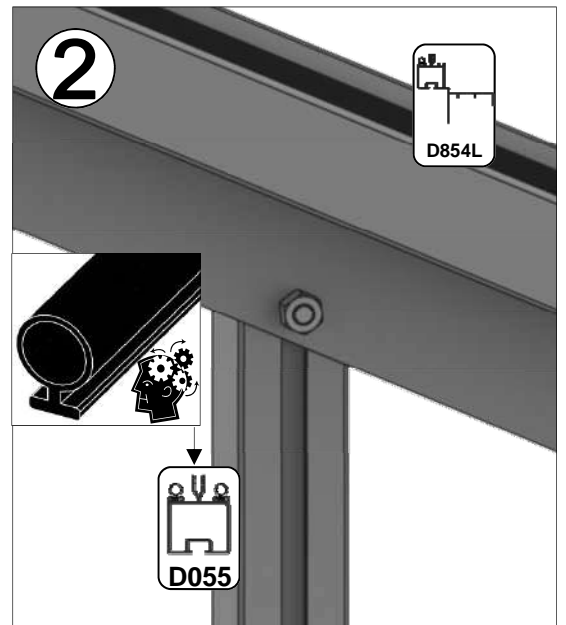
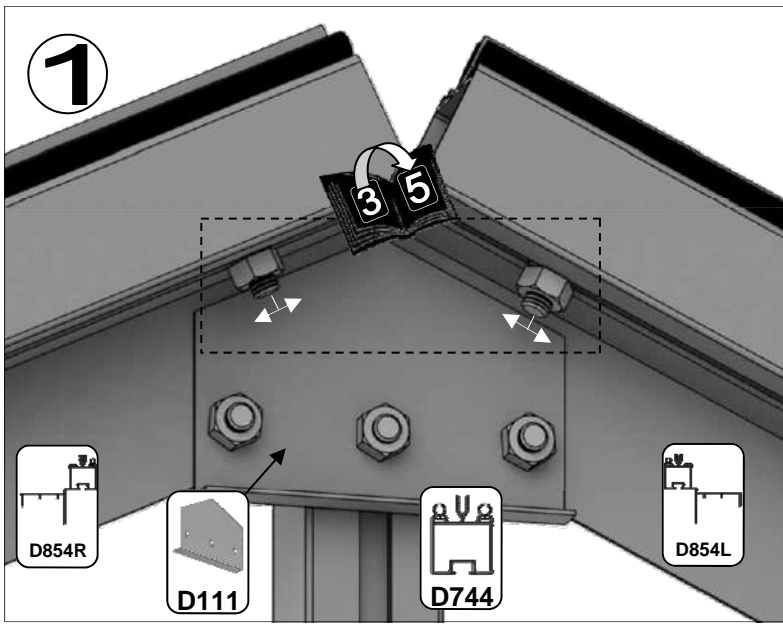

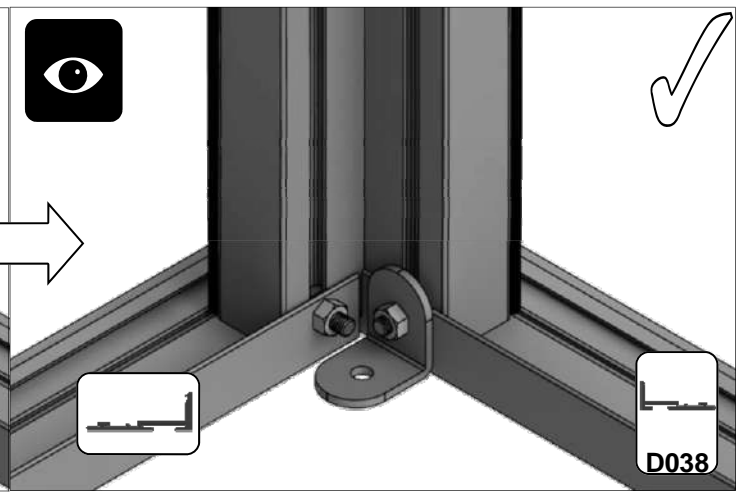
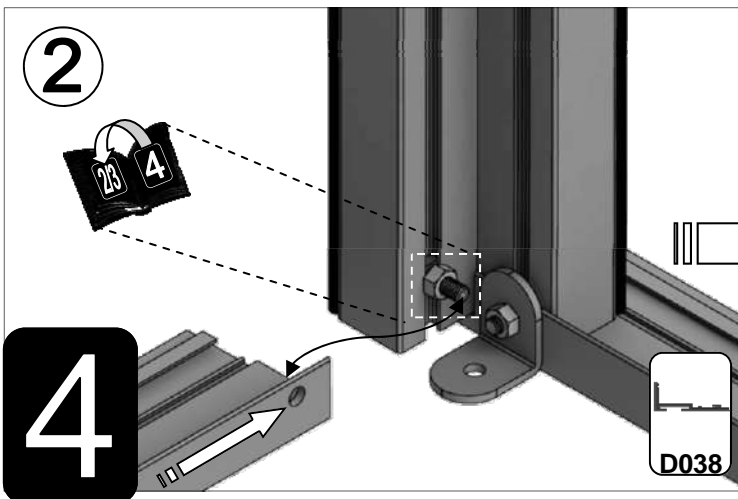
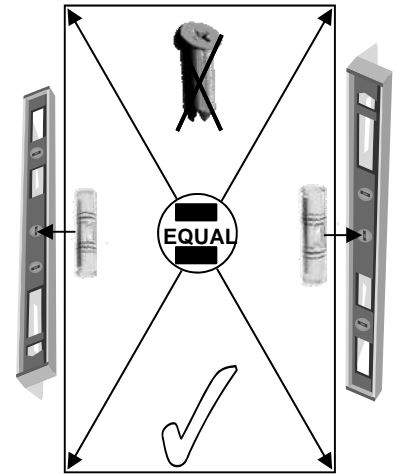
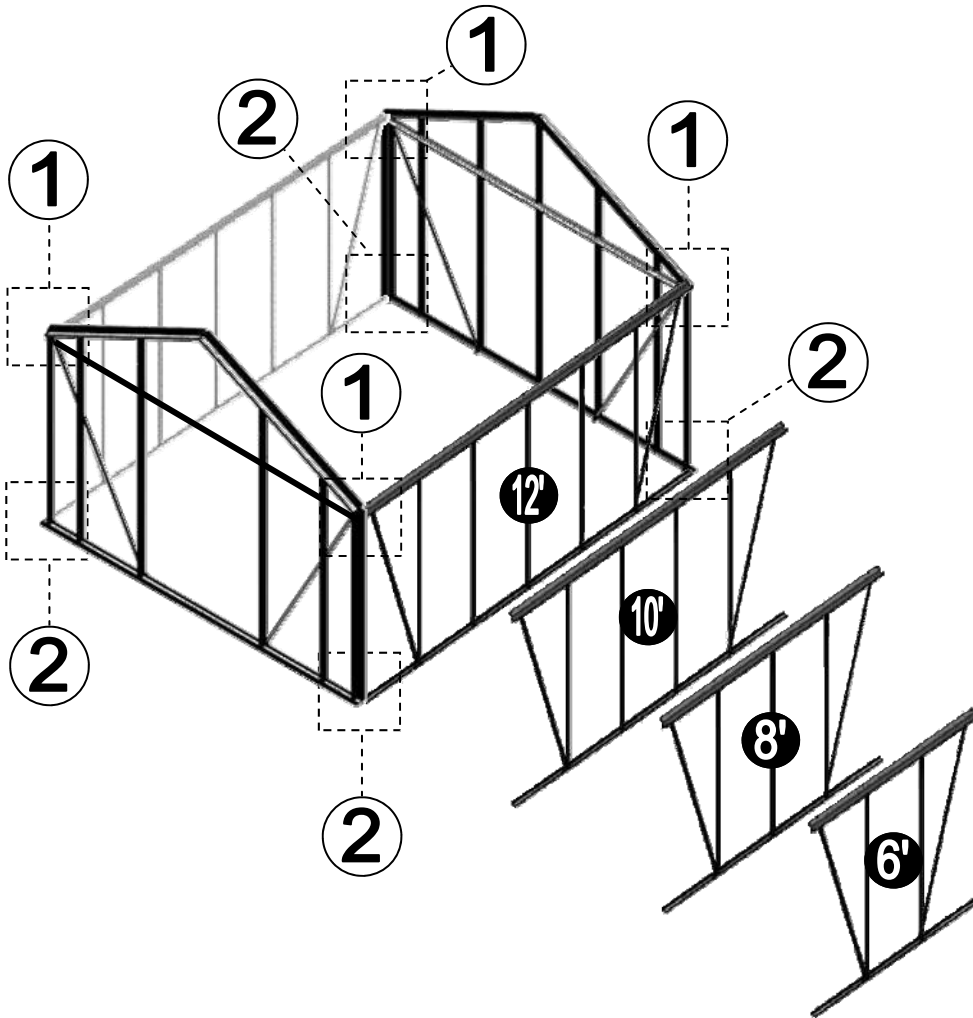
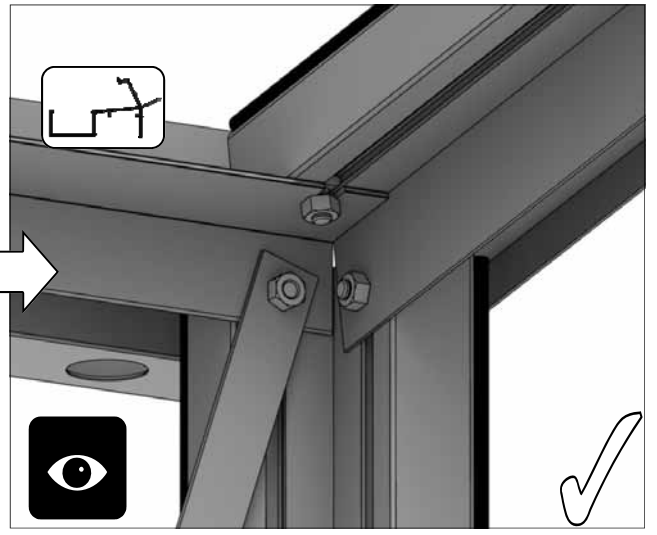
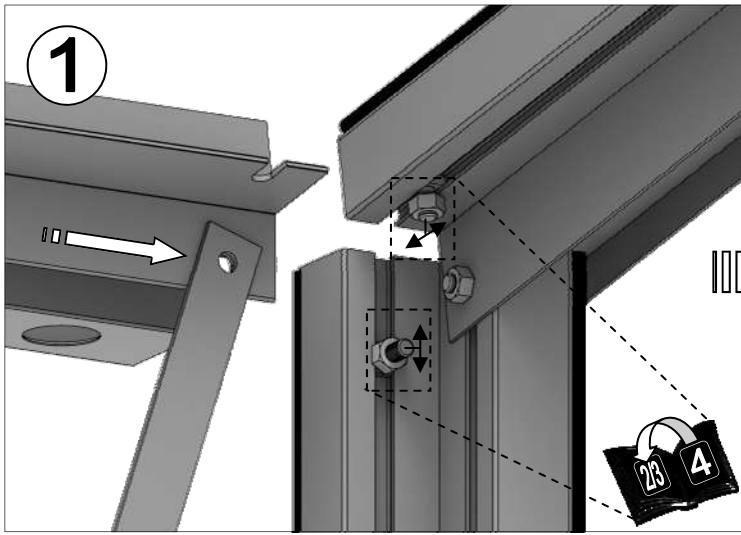

6'		
Part No	mm	Quantity
D044	1897	1
D065	1744	4
D126	445	0
D128	1015	0
RUBBER	1000	14

8'		
Part No	mm	Quantity
D001	2517	1
D065	1744	6
D126	445	2
D128	1015	1
RUBBER	1000	21

10'		
Part No	mm	Quantity
D002	3137	1
D065	1744	8
D126	445	4
D128	1015	2
RUBBER	1000	28

12'		
Part No	mm	Quantity
D003	3757	1
D065	1744	10
D126	445	6
D128	1015	2
RUBBER	1000	35

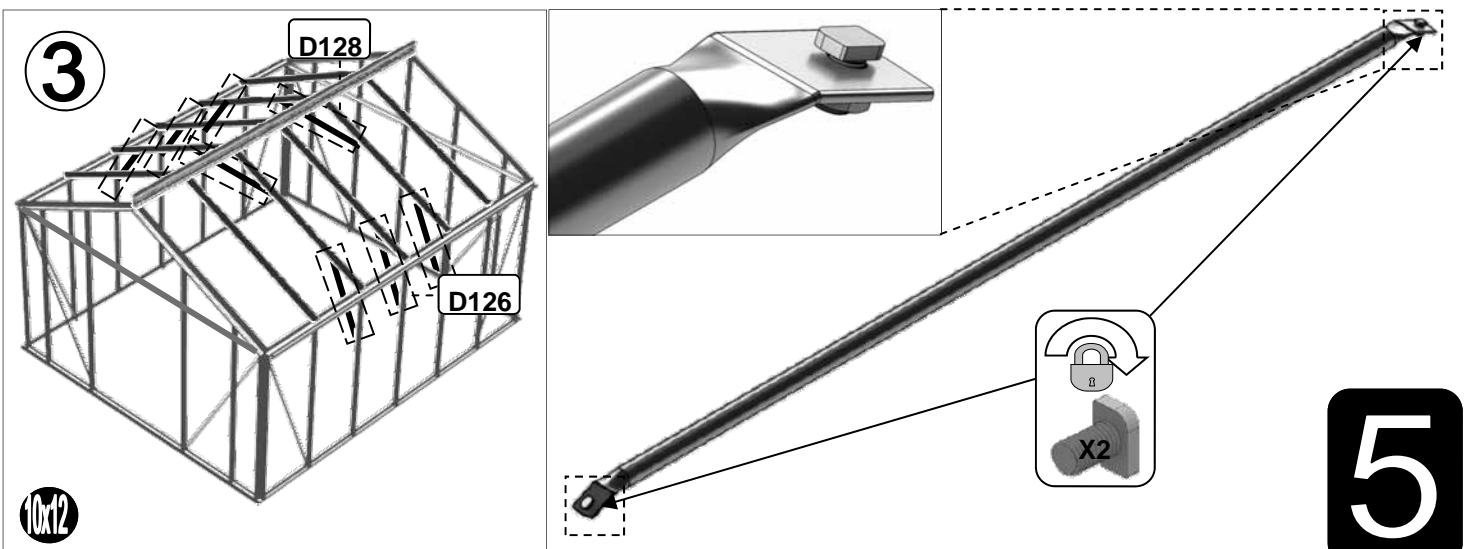
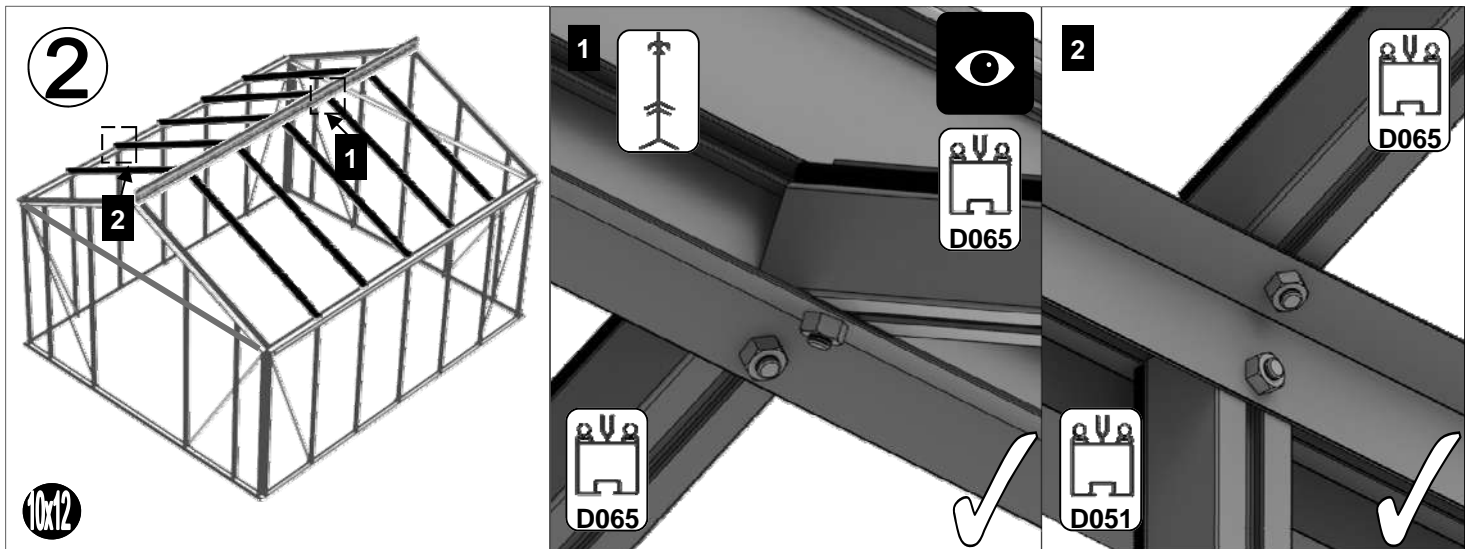
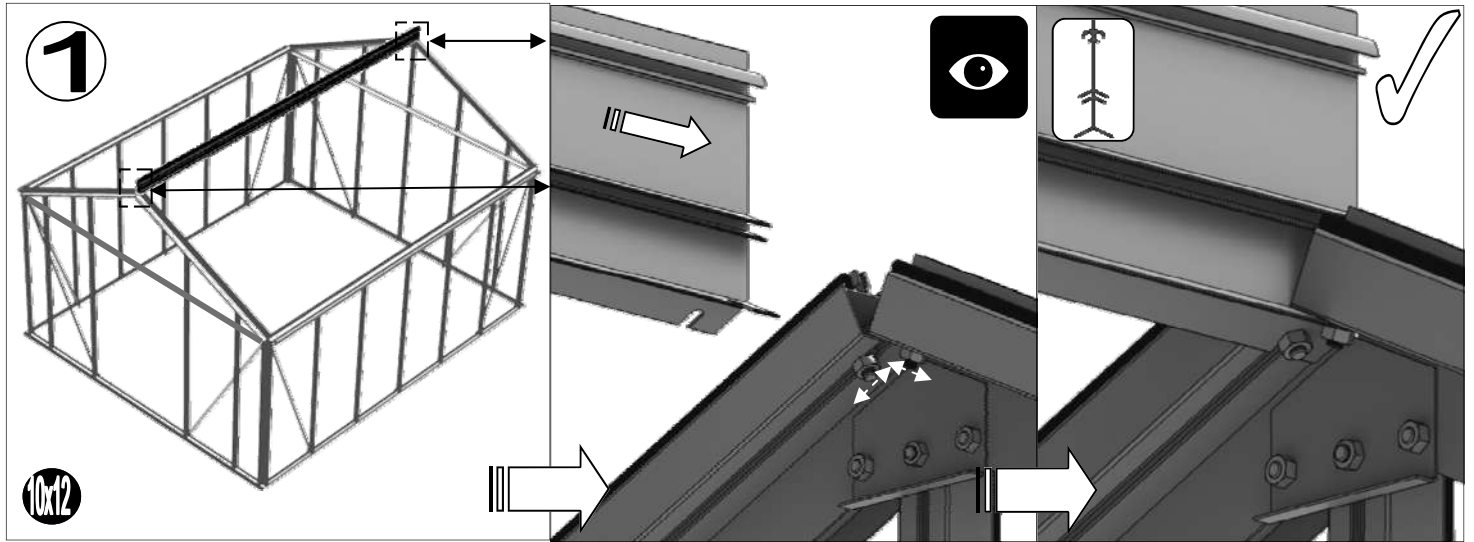

5



1 Dakraam = {



D1208
1 of -
610 x 610
Glasplaat

Part No		mm	Quantity
D866		639	1
D863L		613	1
D863R		613	1
D862		593	1

Part No		mm	Quantity
D220 PLUS FS6060 SCREW		N/A	2
D205		N/A	2
SY-BOLM6X11		10	4
SYNUTM6		M6	4
8 X 12 S/T FS6017		10	2
8 x 19 S/T FS6018		19	2

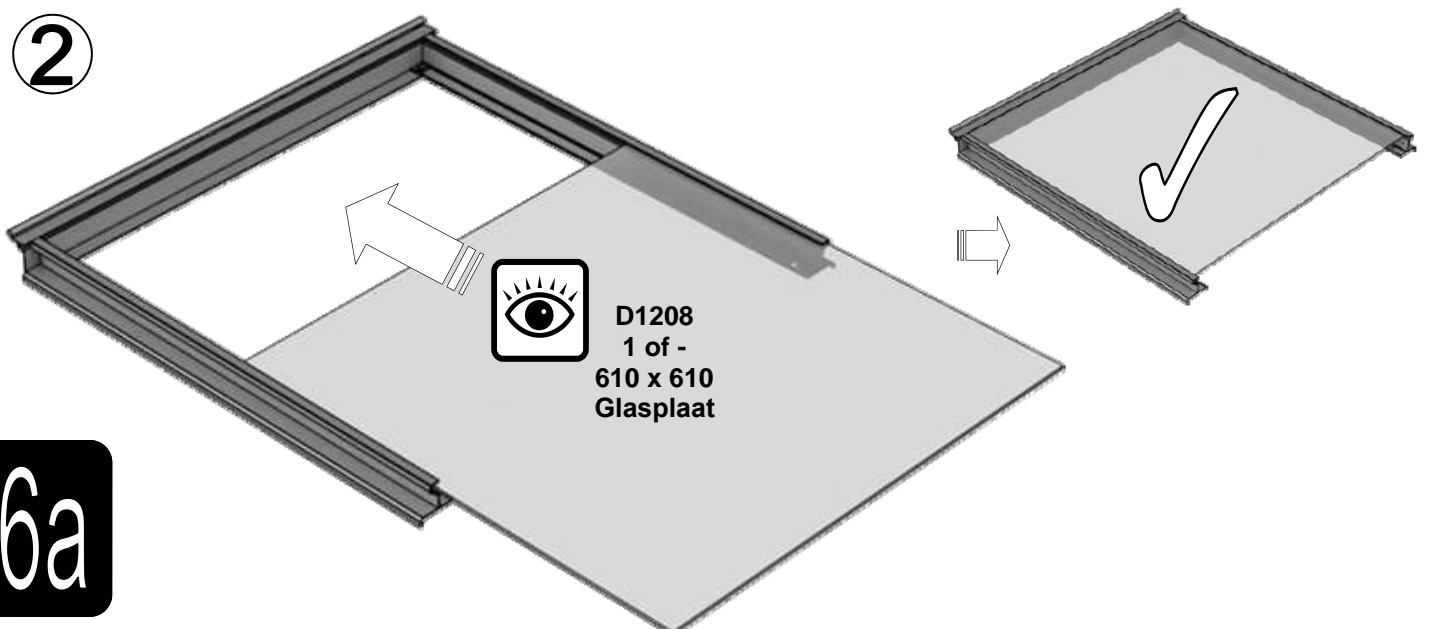
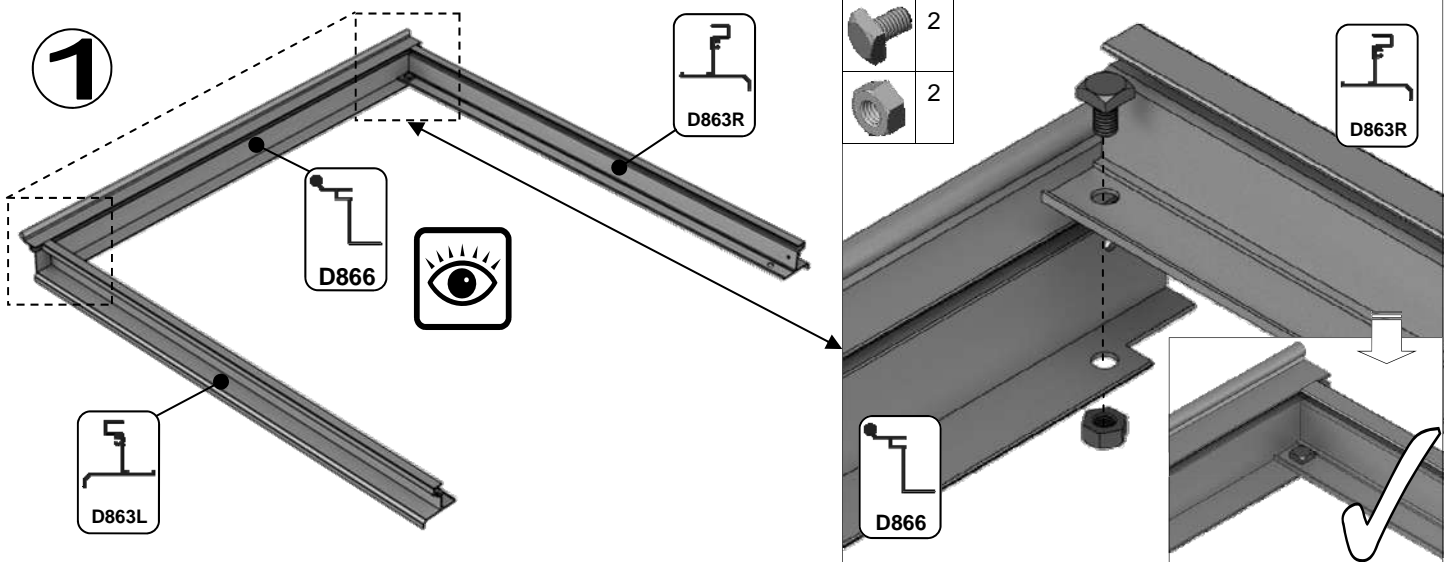

6a

3 

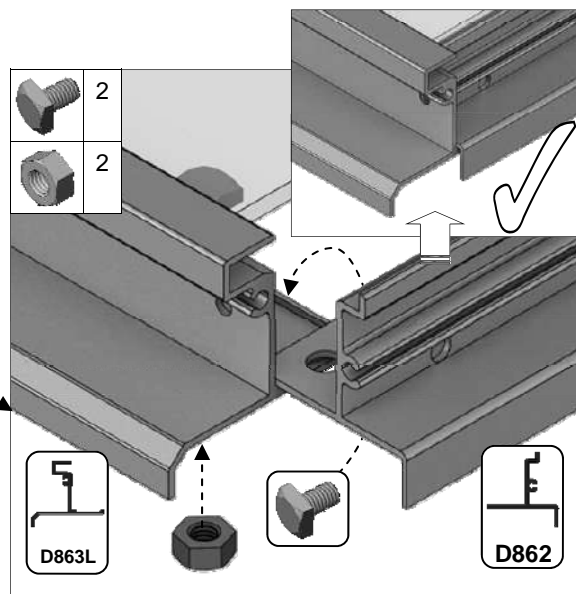
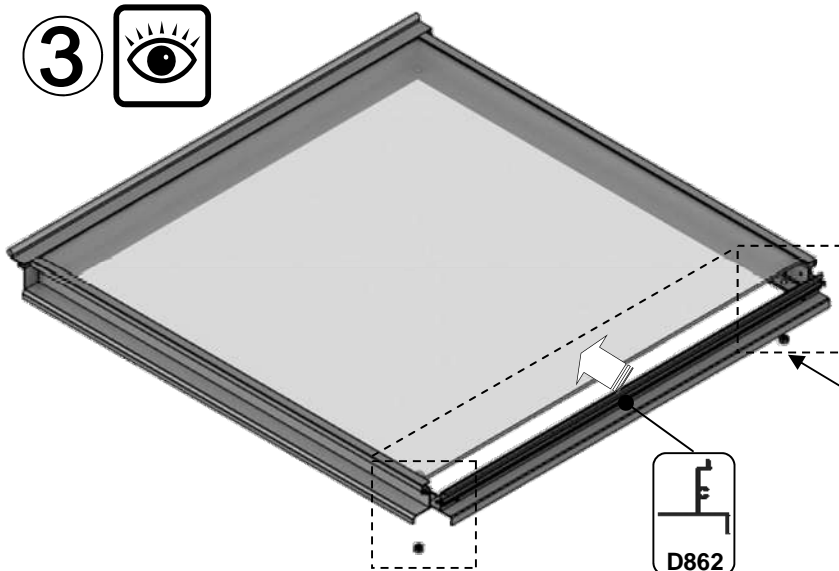

4 

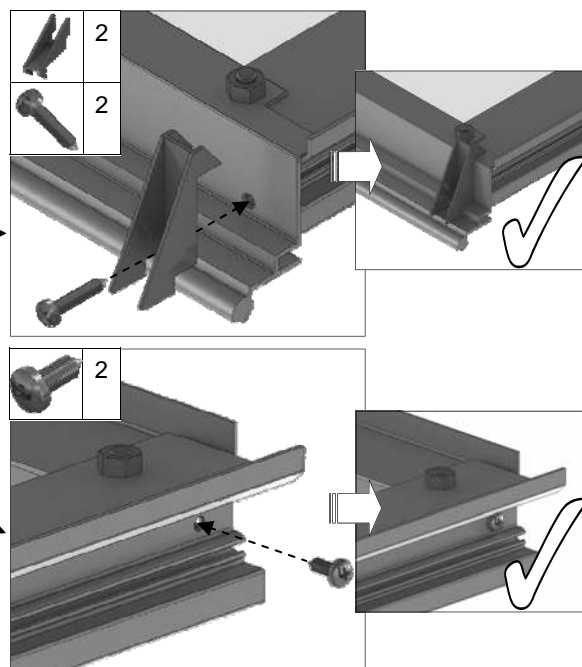
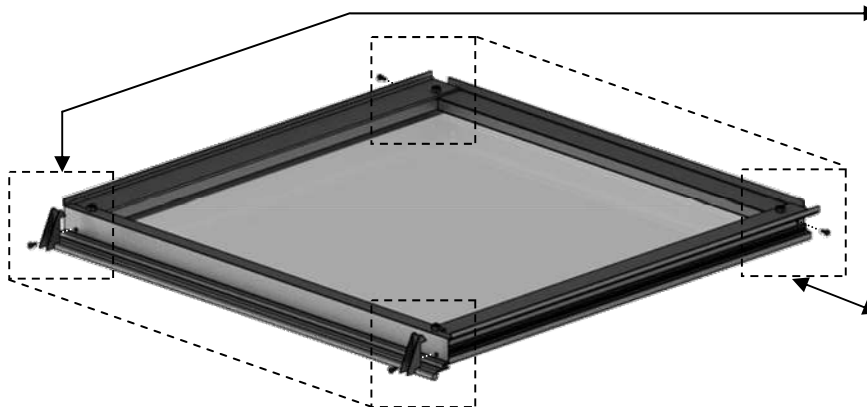
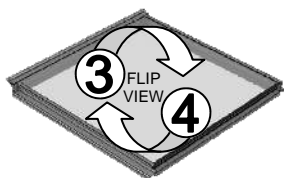

5 

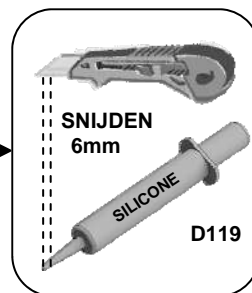
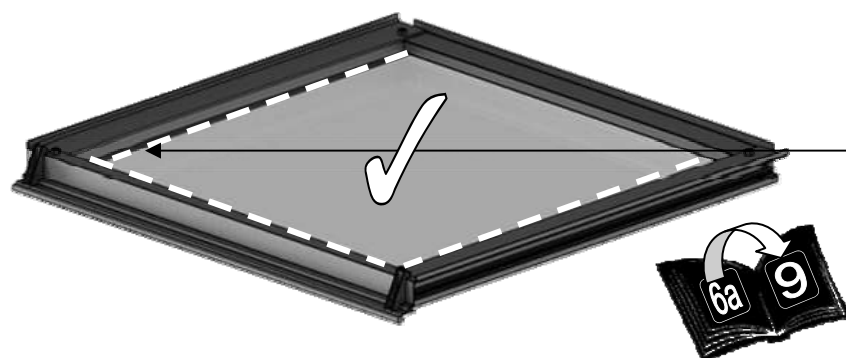

6a

1 Raamdorpel = {

Part No		mm	Quantity
SY-BOLM6X11		10	2
SY-BOLM6X15		15	2
SYBOLM6 X11CROP		10	2
SYNUTM6		N/A	4

Part No		mm	Quantity
D079 PLUS FLUFF		590	1
D114		N/A	2

6

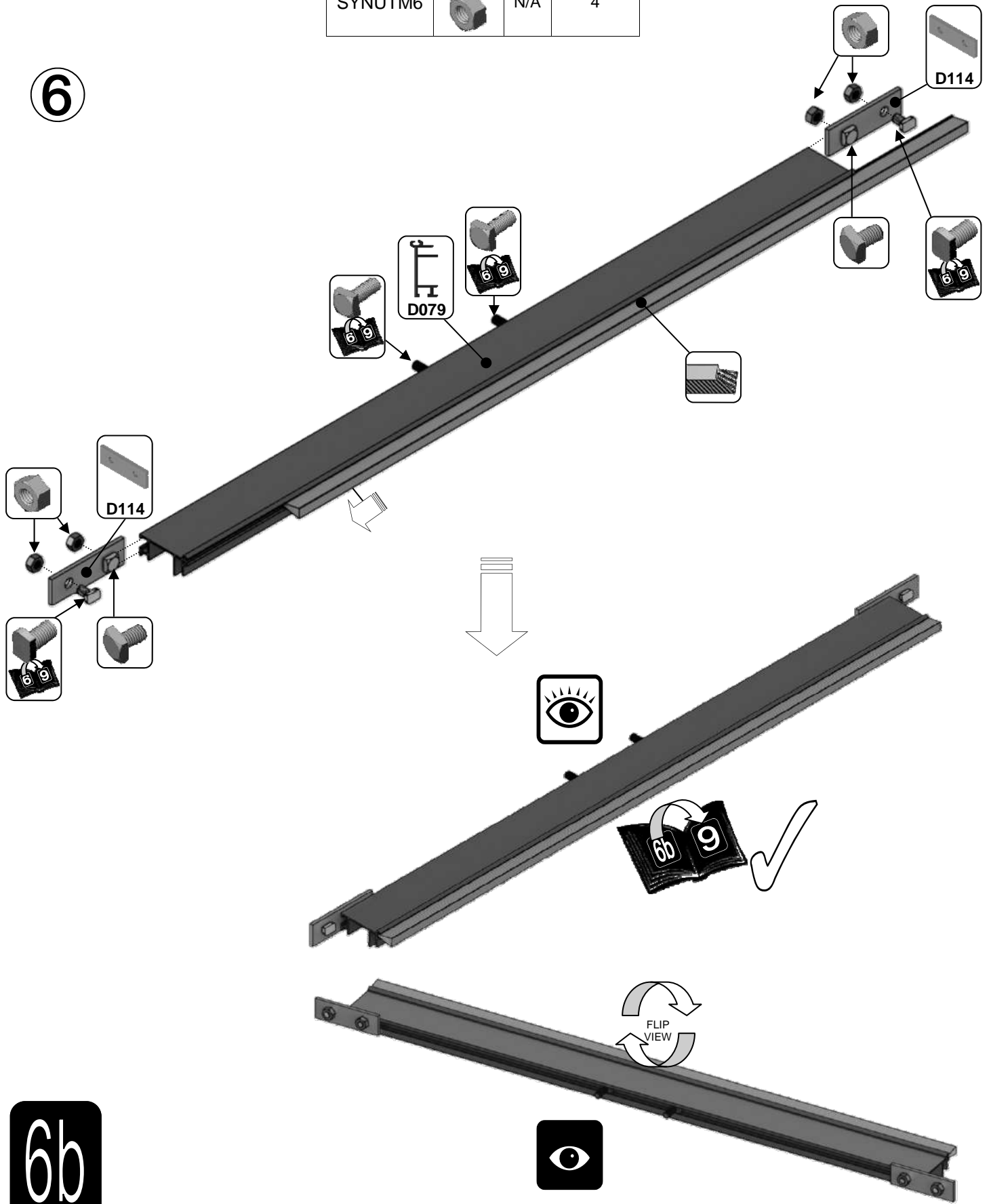

6b

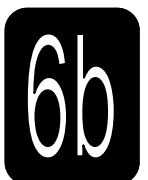
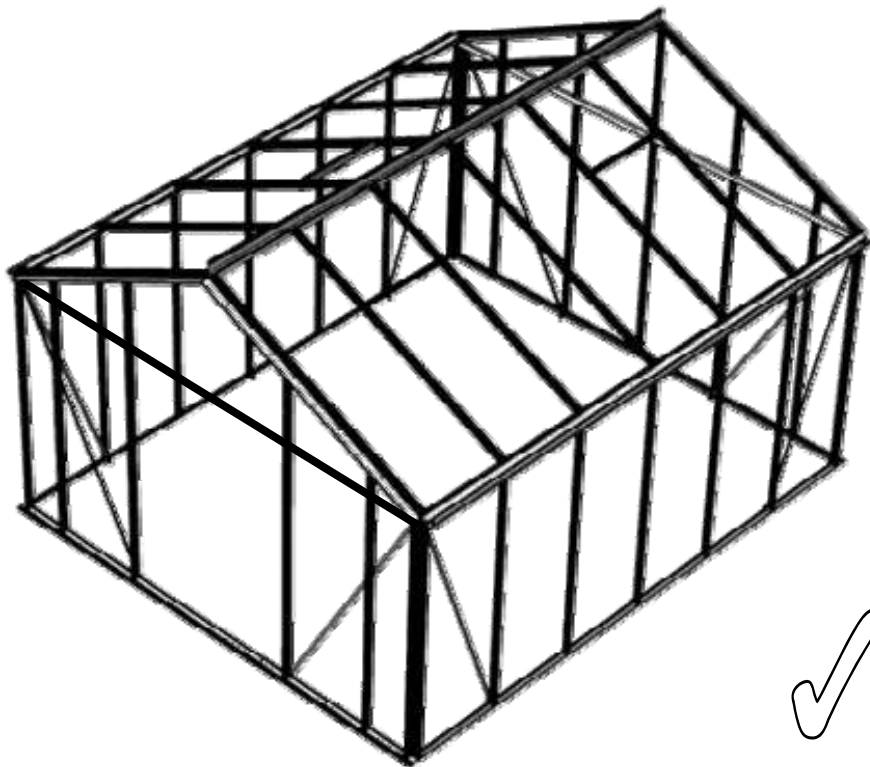
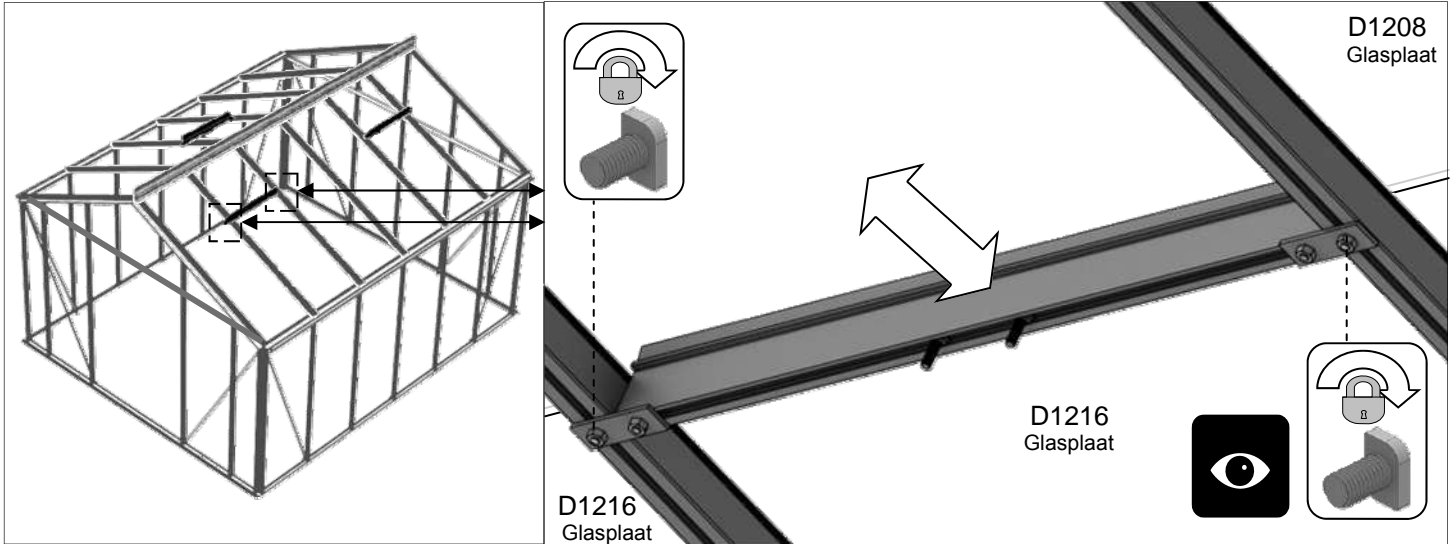
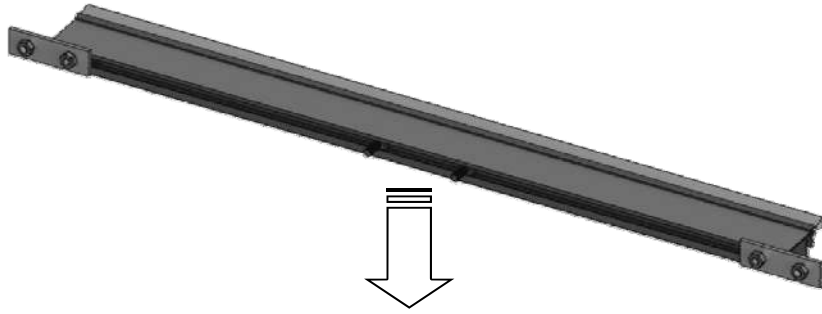

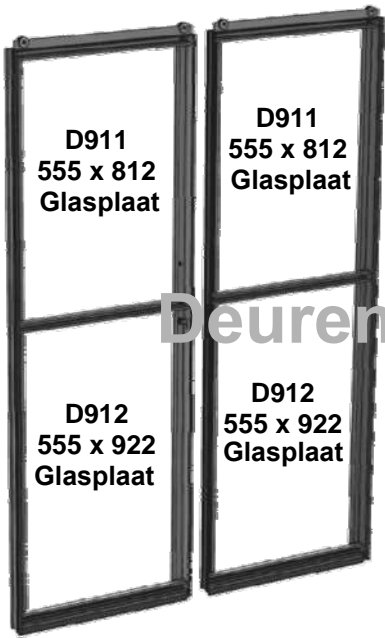

Deuren = {

Part No		mm	Q
D094		1824	1
D090 + D347 lock = D301		1824	1
D092 + D156 strike = D303		1824	1
D093		1824	1
D096 + D217 wheel = D307		611	2
D095		611	2
D097		611	2

Part No		mm	Q
D232		905	4
D233		797	4
P053		N/A	2
D225		610	2
D840B		4000	1
D263 PACK x 2		N/A	14
		N/A	14
D261 PACK		N/A	24

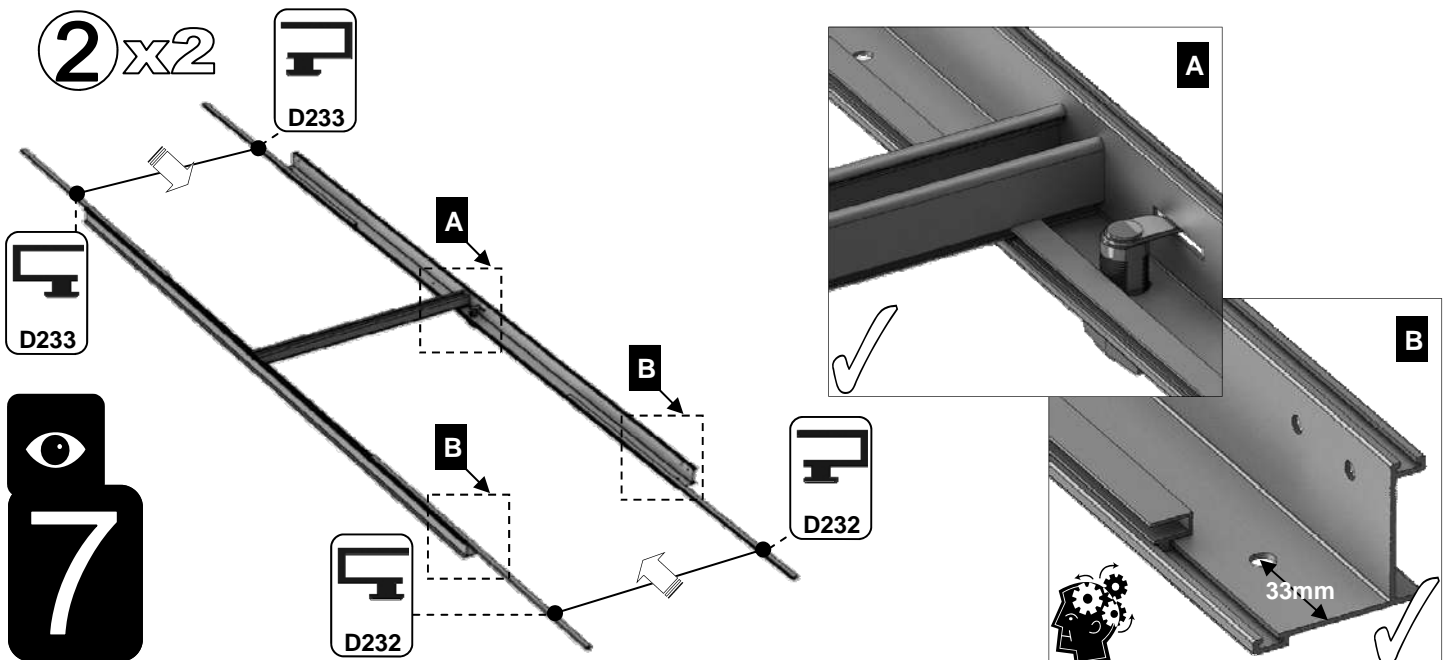
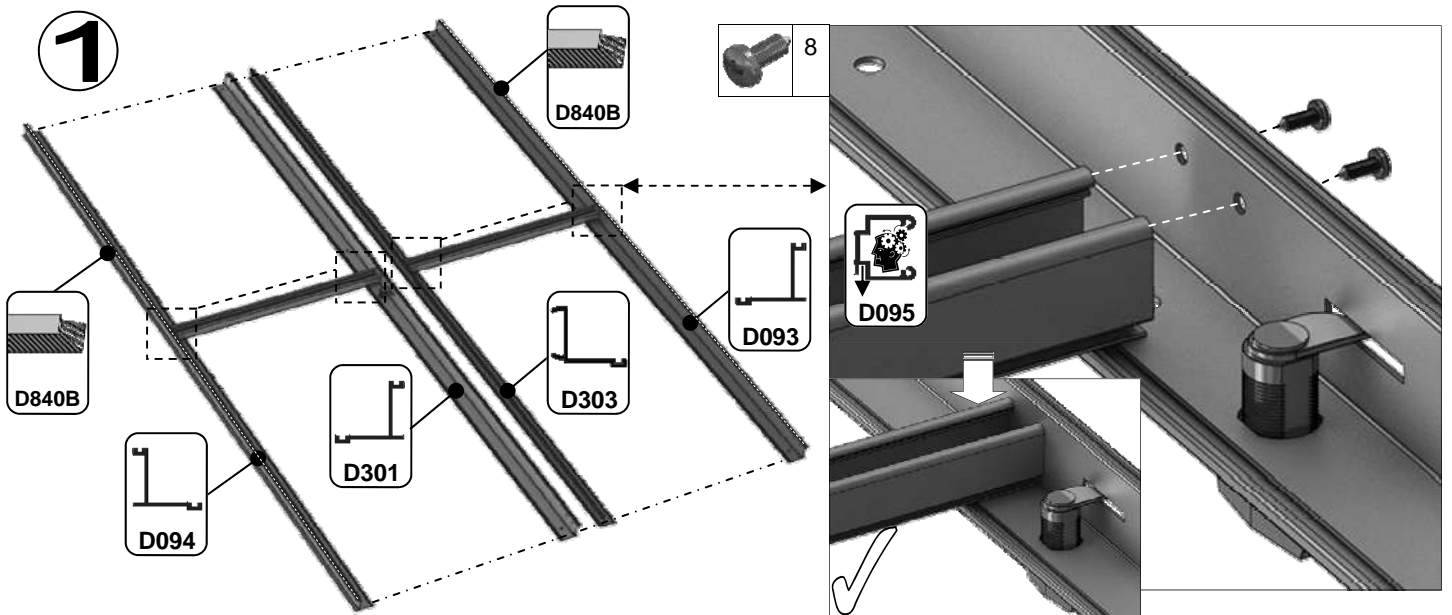

3 x2

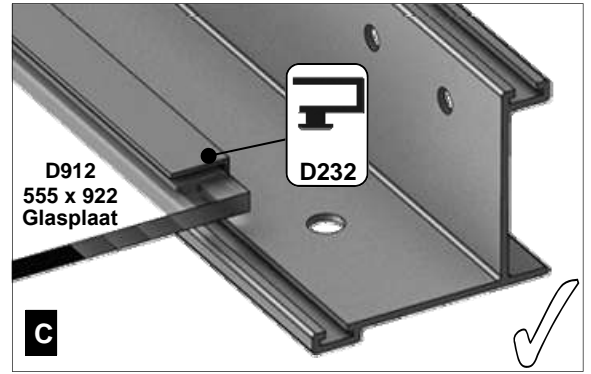
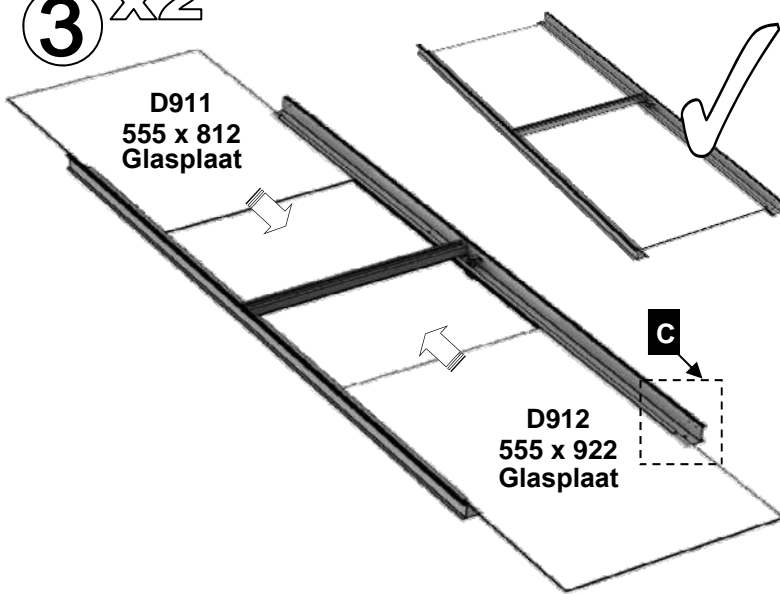



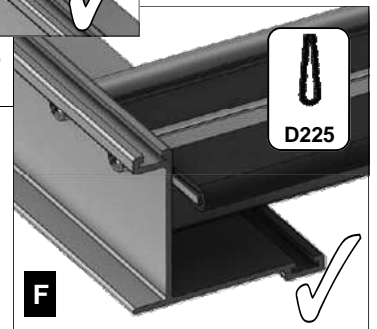
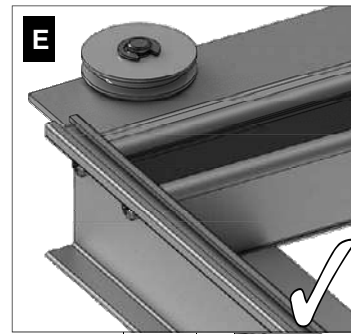
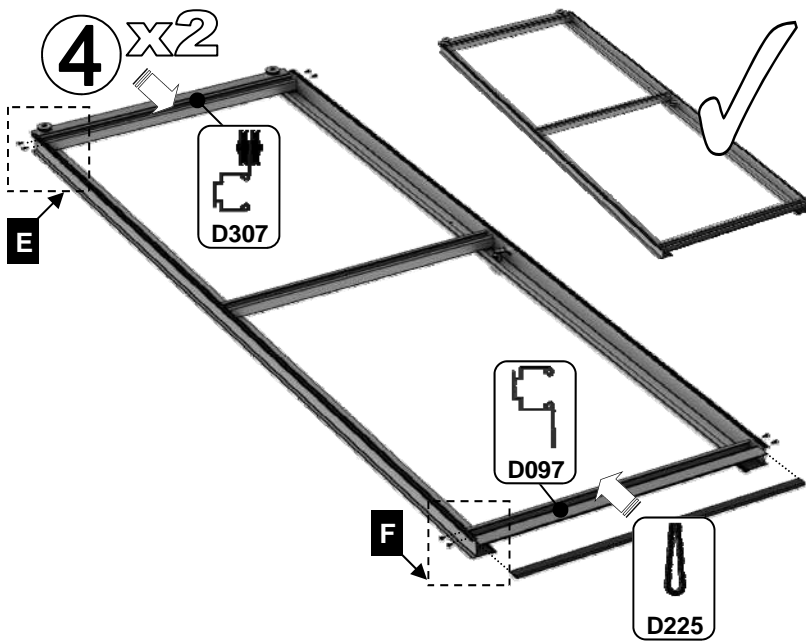

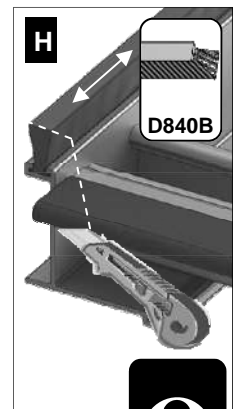
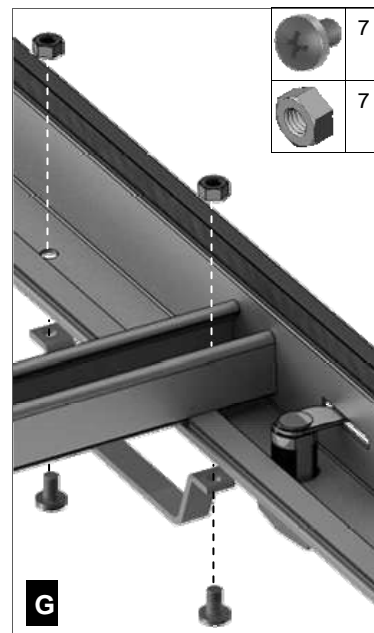
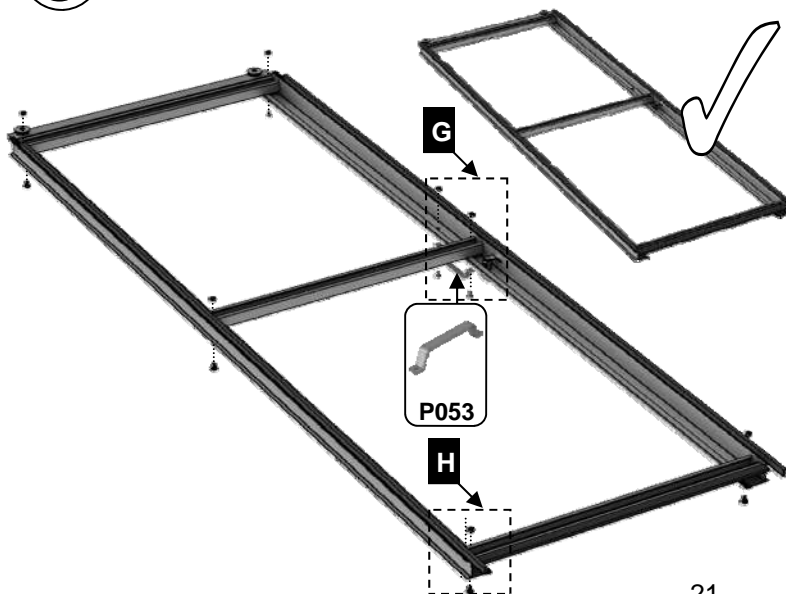

4 x2



5 x2



PART No	Section	Size (mm)
D746		2718
D748		787
D816		1976
D818		2126
D822		2422
D823		516
D870		601
D876		1152
D781		1976
D814		1883
D871		601
D877		1152
D747		2718
D749		787
D811		1754
D828		1978
D829		2128
D832		2424
D833		518
D836		1883

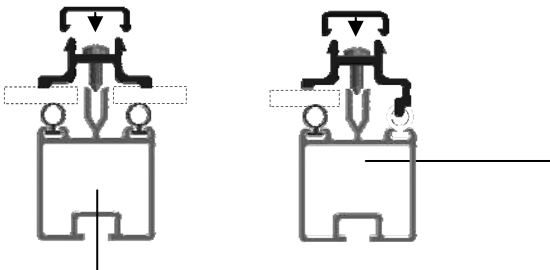
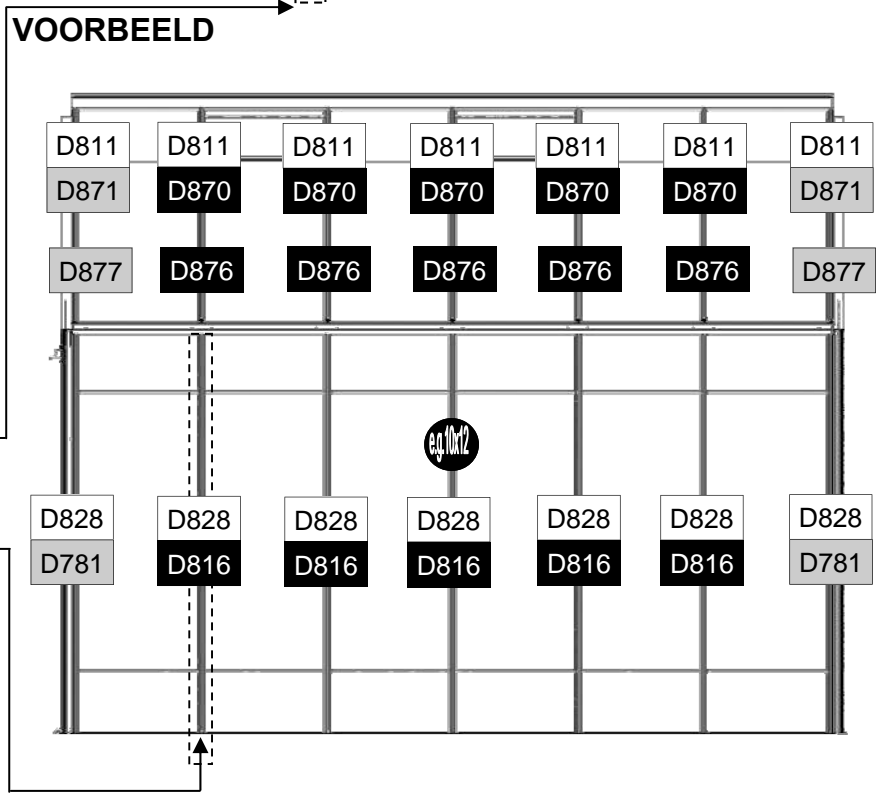
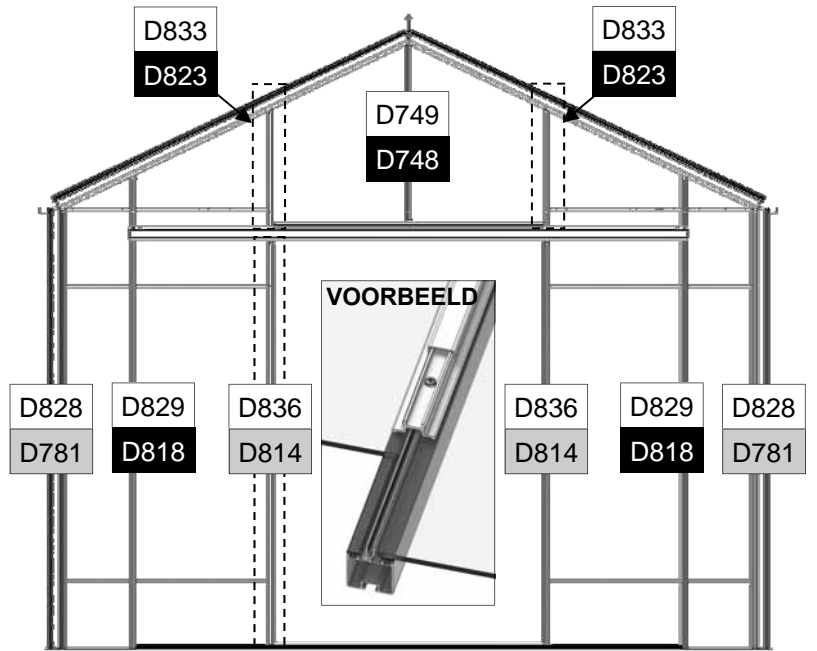
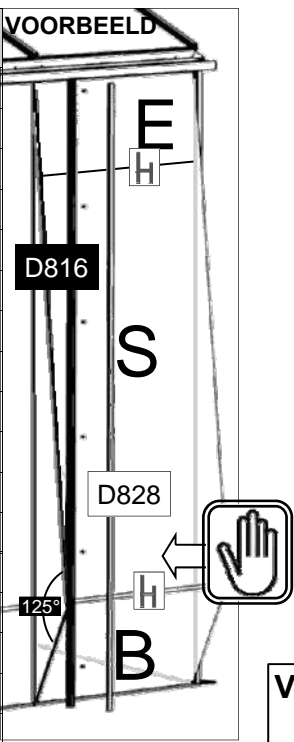

VOORBEELD

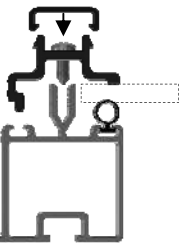

VOORBEELD

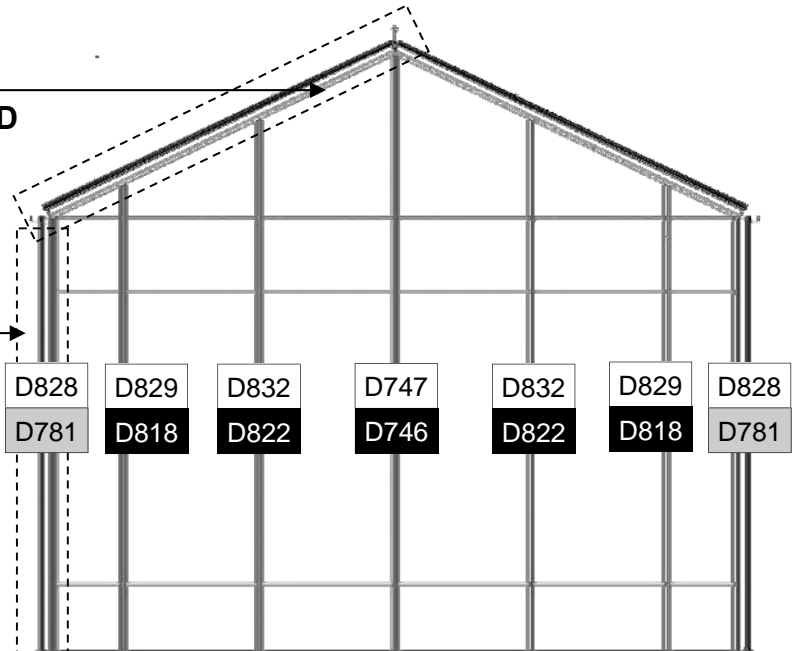

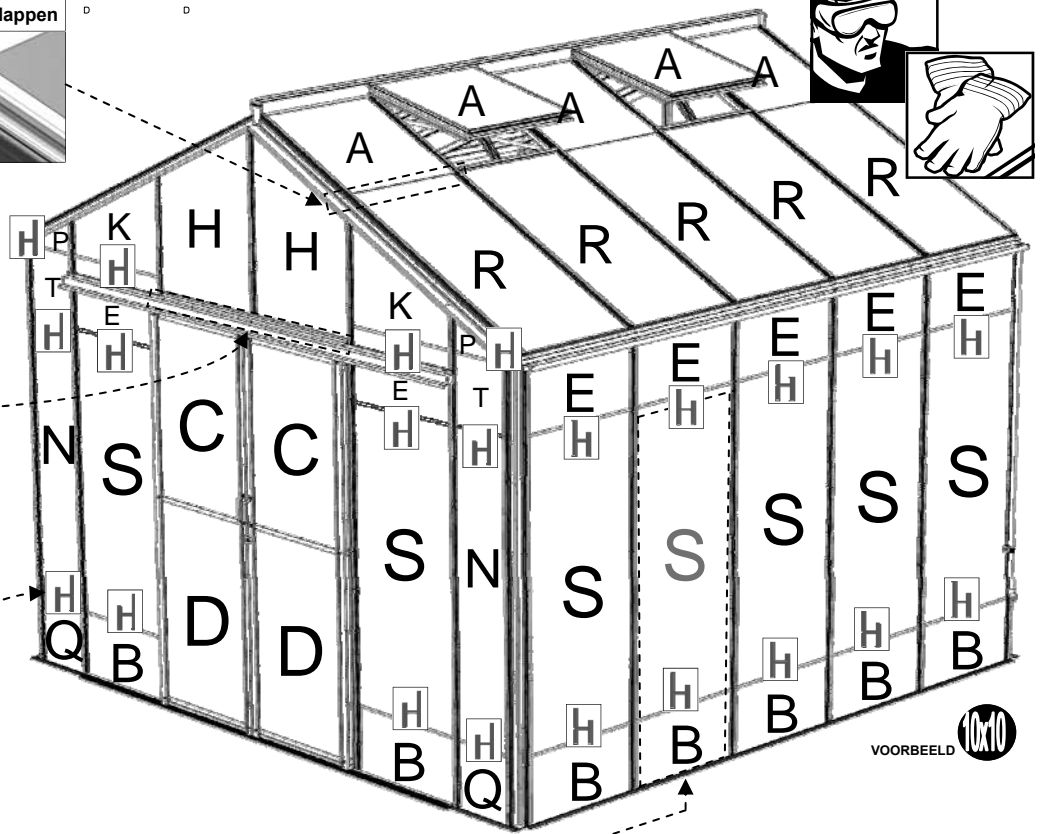
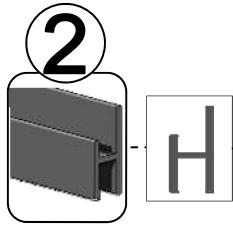
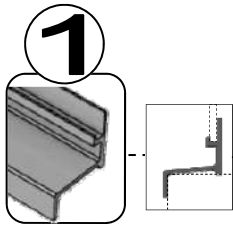
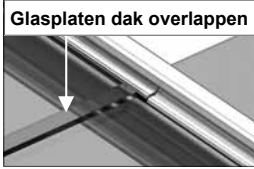

VOORBEELD

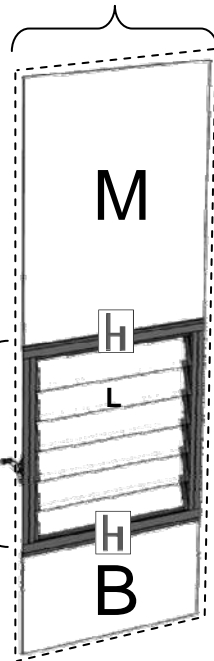
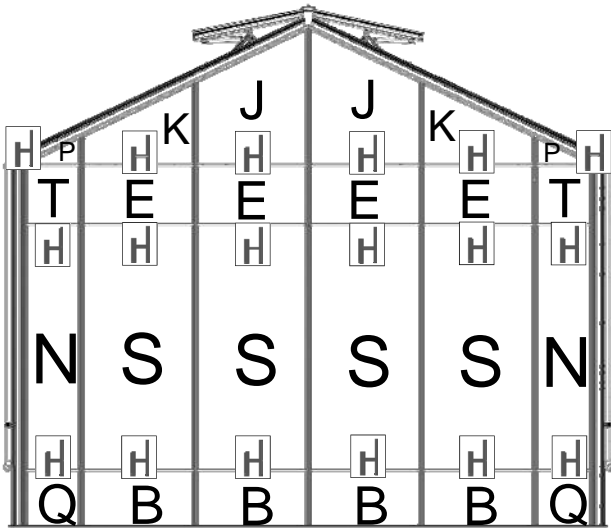

PART No	Size (mm)	6'	8'	10'	12'	
-	E	610 X 300	12	14	16	18
D1206	S	610 X 1374	11	12	14	16
D1216	R	610 X 1162	6	8	10	12
D1208	A	610 X 610	6	8	10	12
D1254	B	610 X 305	12	14	16	18
D707	T	305 x 300	4			
D904	N	305 X 1374	4			
D905	Q	305 X 305	4			
D911	C	555 X 812	2			
D912	D	555 X 922	2			
D899	H	ANGLE	2			
D901	K	ANGLE	4			
D902	P	ANGLE	4			
D907	J	ANGLE	2			
D223/B		1210	1			
D101 / ROSEPS	H	610 long (inc cuts to 305mm)	36	40	44	48

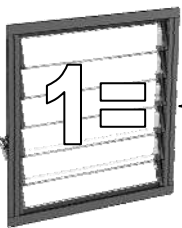



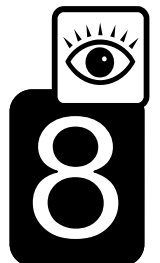
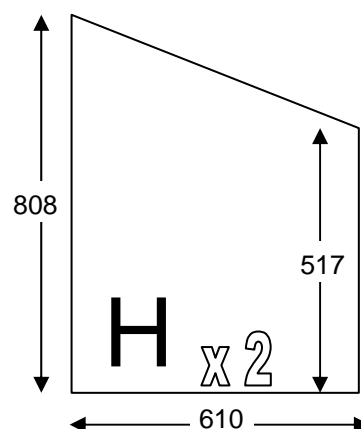
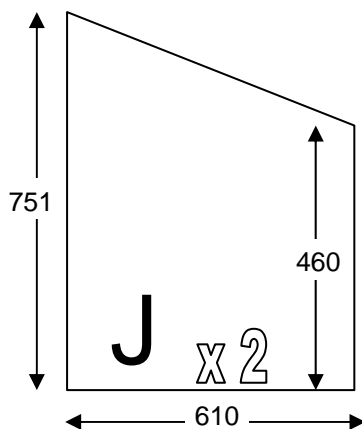
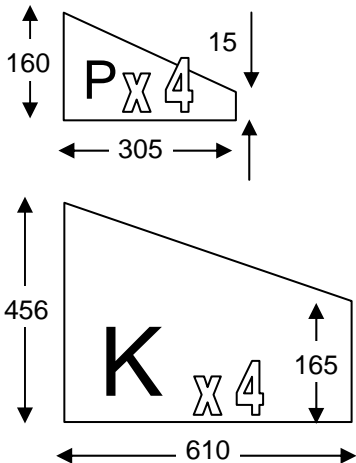

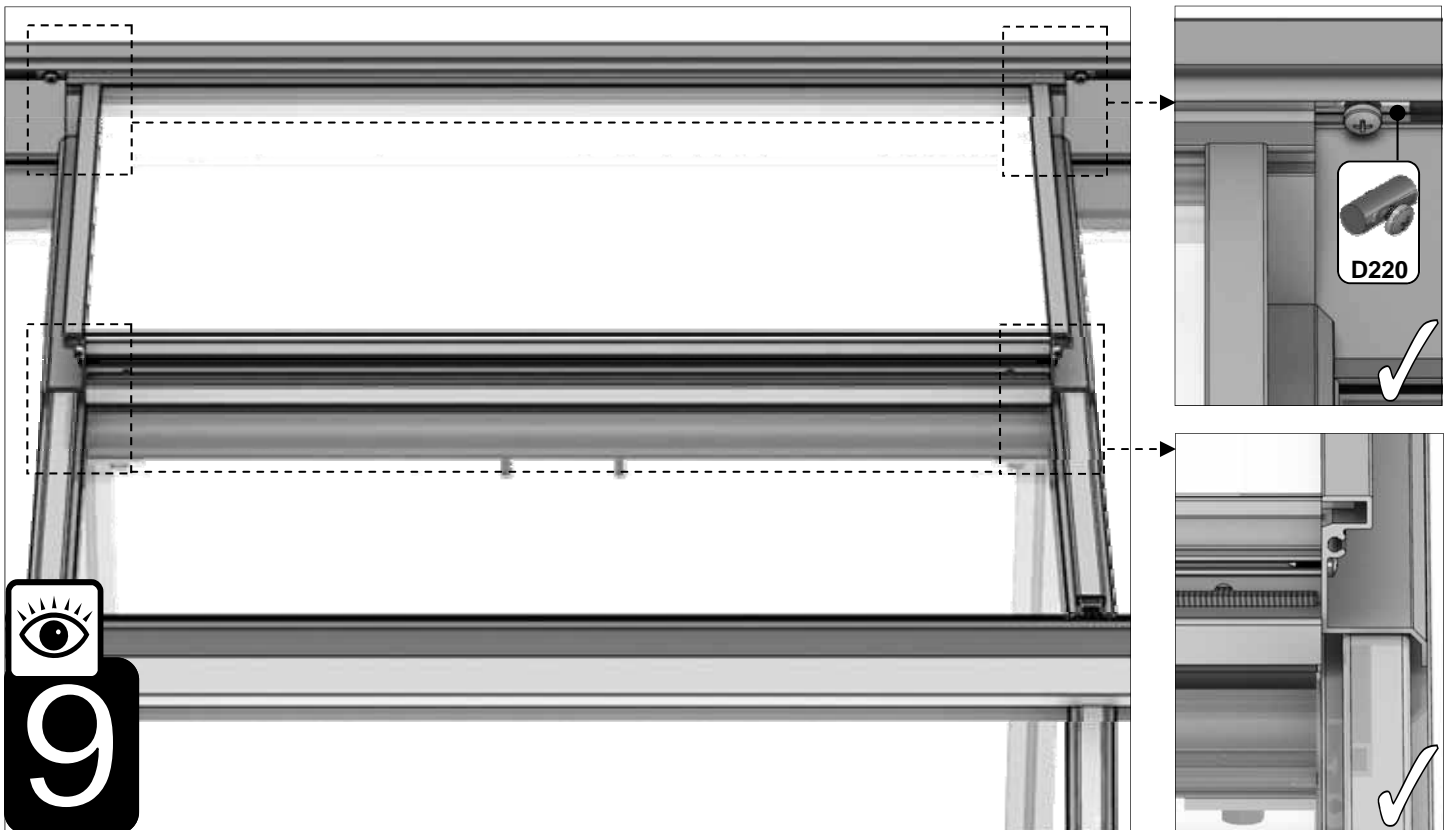
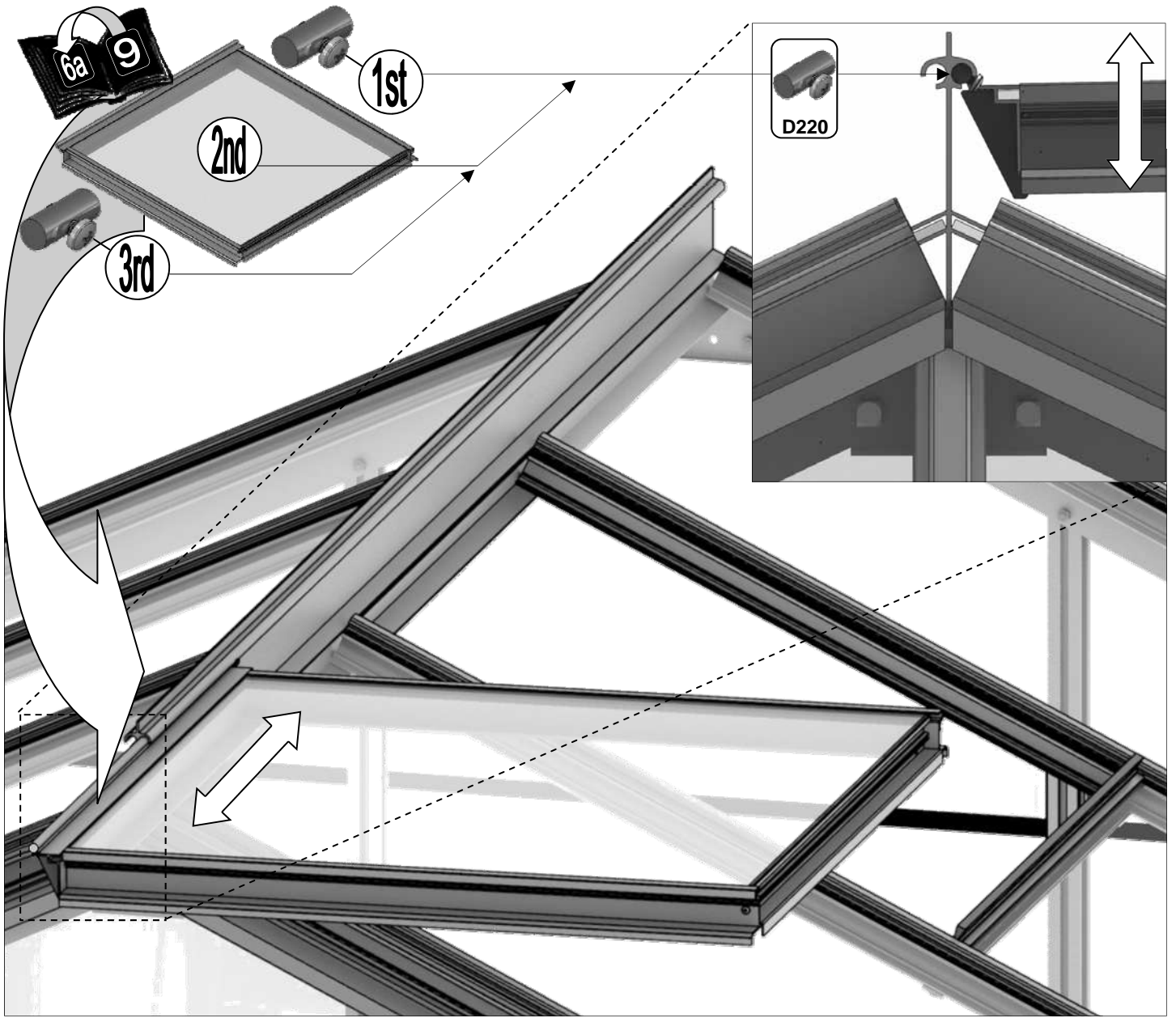

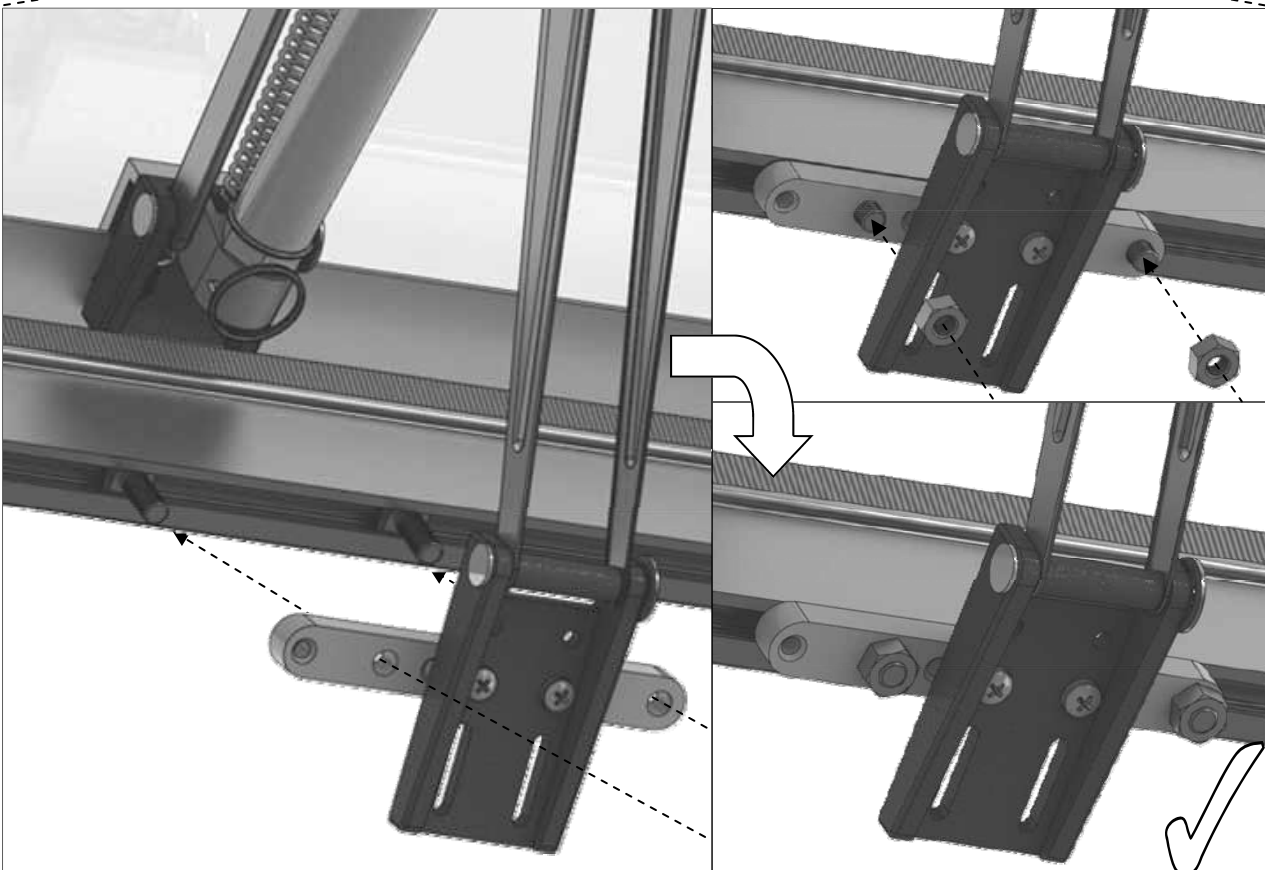
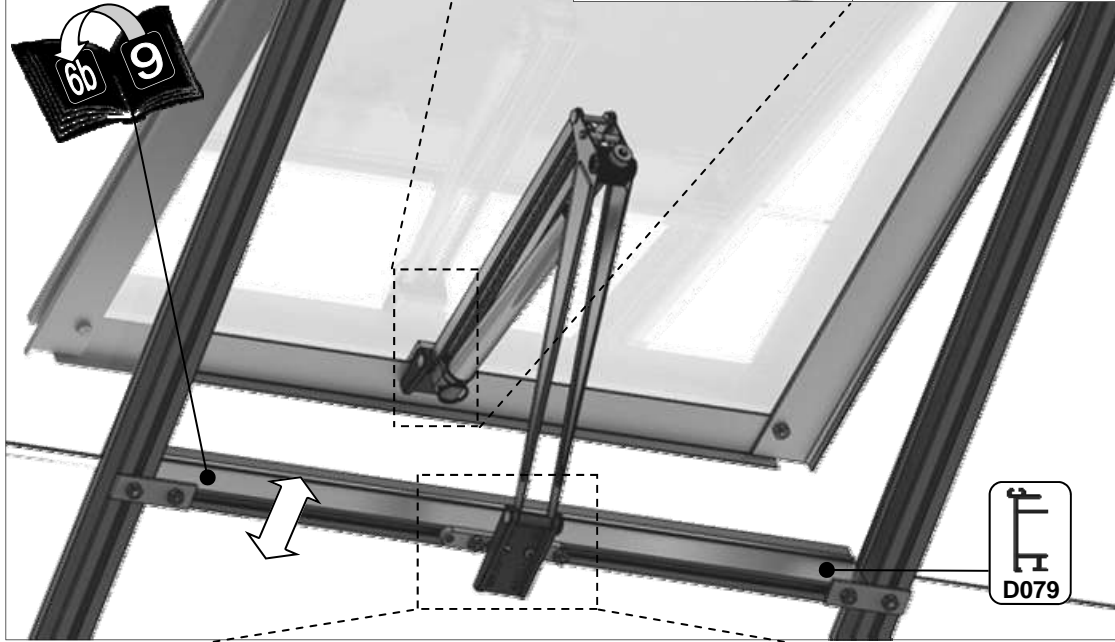
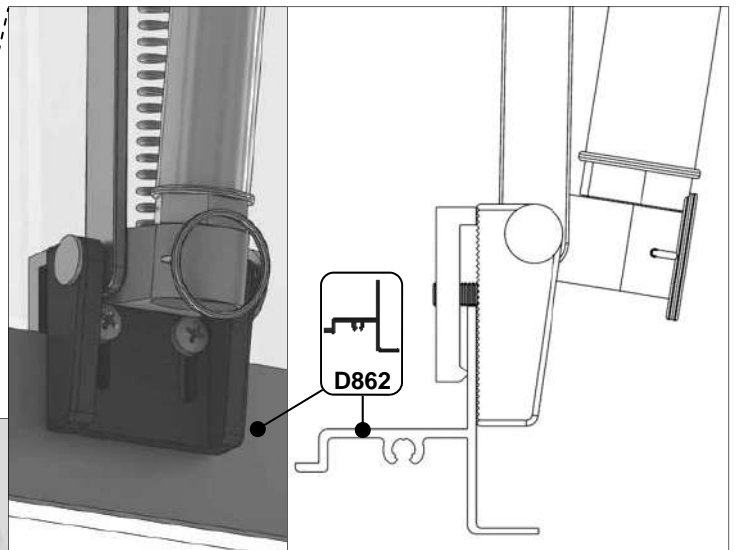
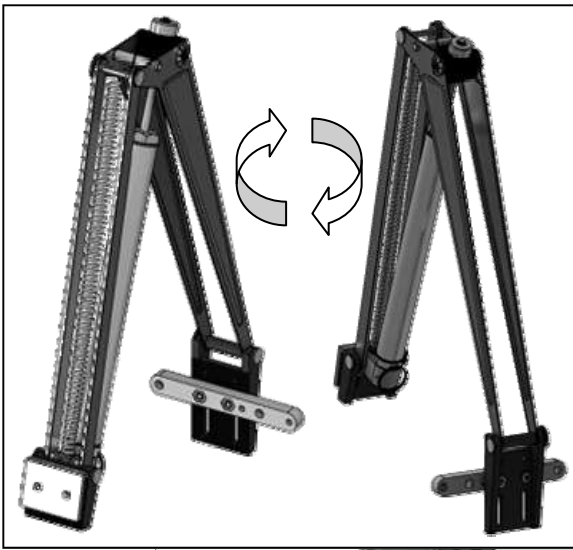

D906	M	610 X 762	1
D729	L	525 X 100	6
D101 / ROSEPS	H	610 long	1







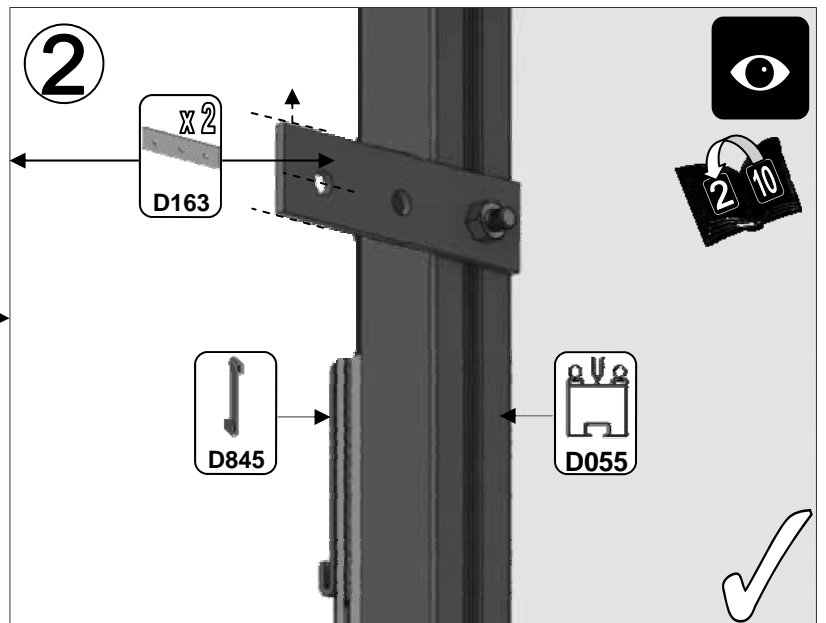
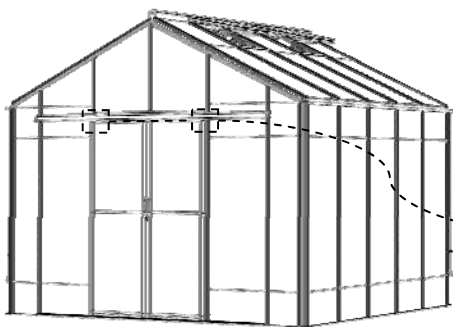
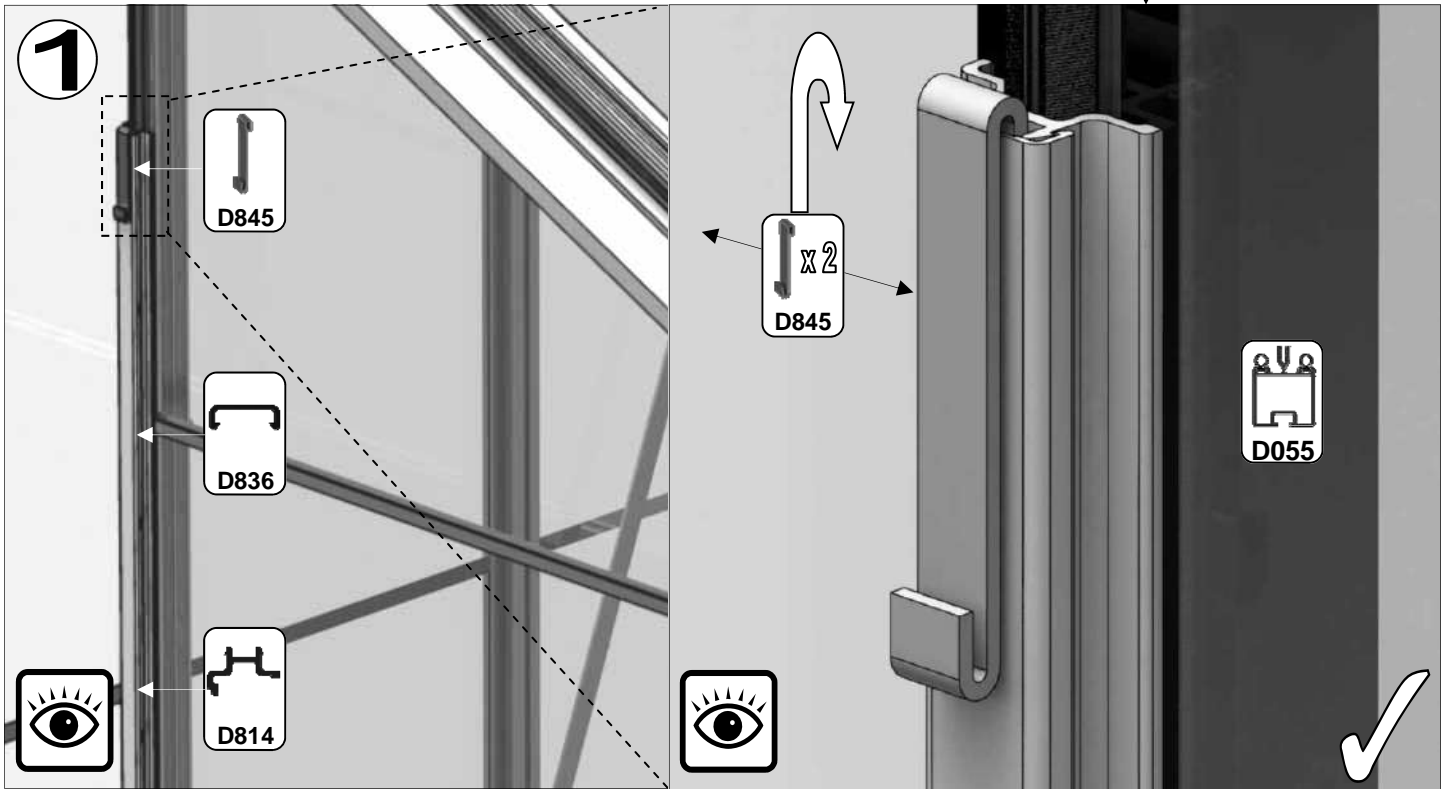
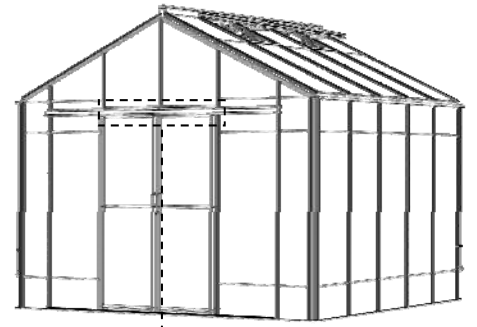

Part No		mm	Q
D865		1210	1
D086		2510	1
D085		2510	1

Part No		mm	Q
D163		90	2
D150			1
D845			2
SY-BOLM6X15			11
SYNUTM6			11

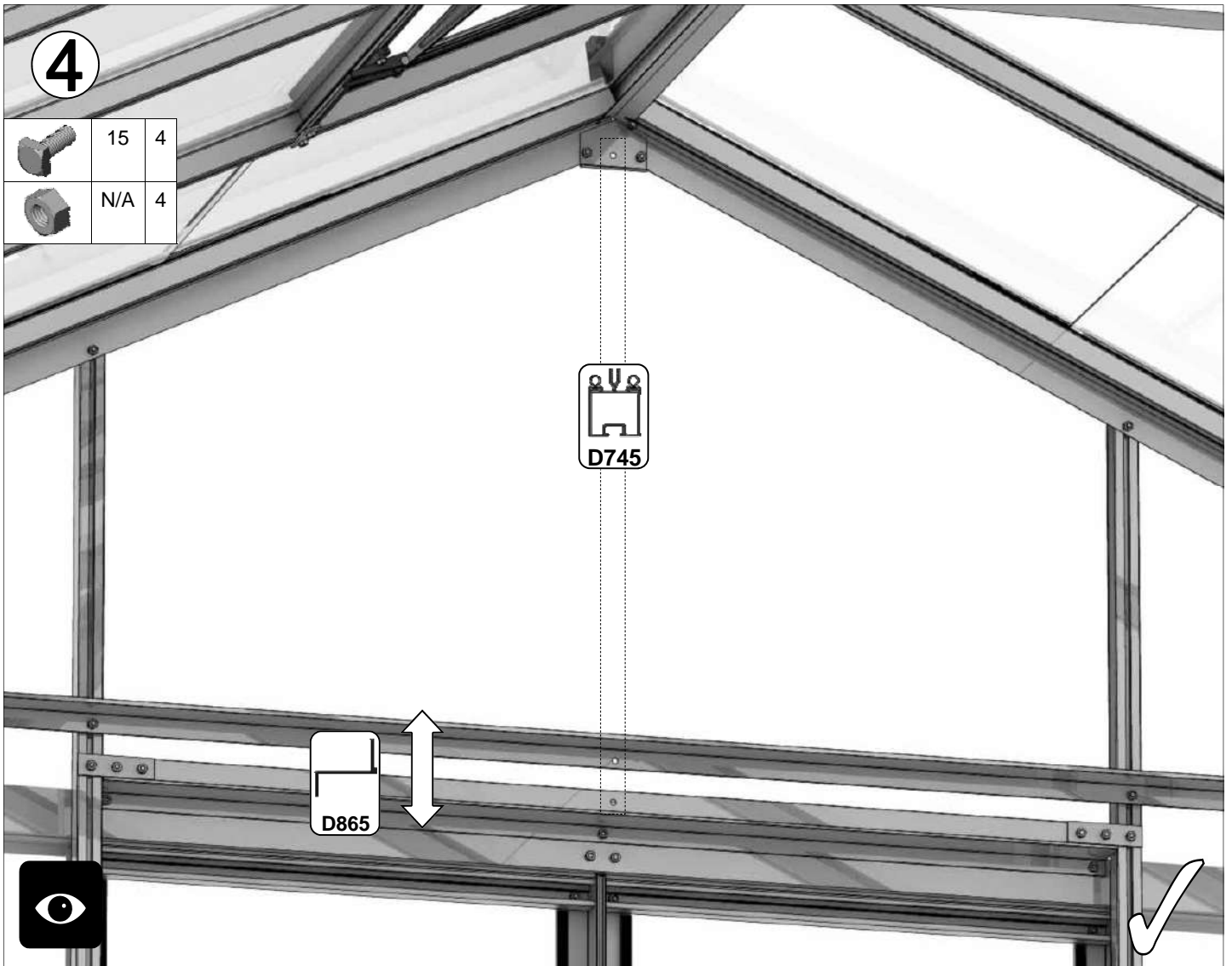
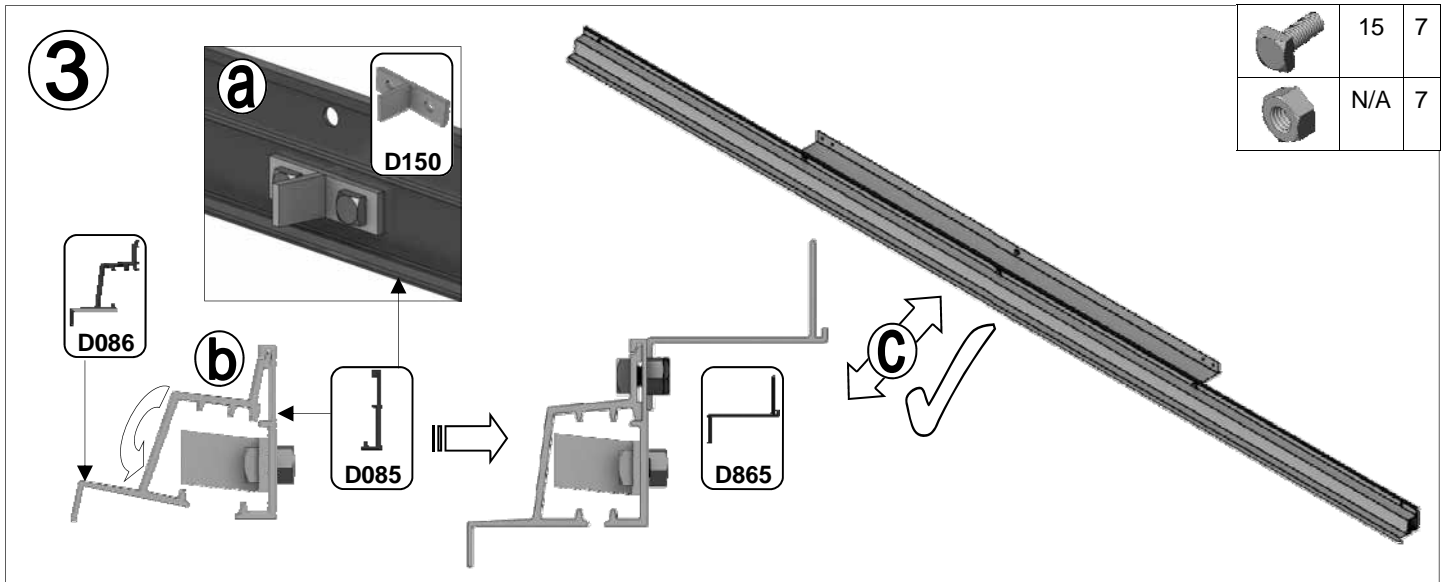

10



Part No		Q
D861		1
D088		1

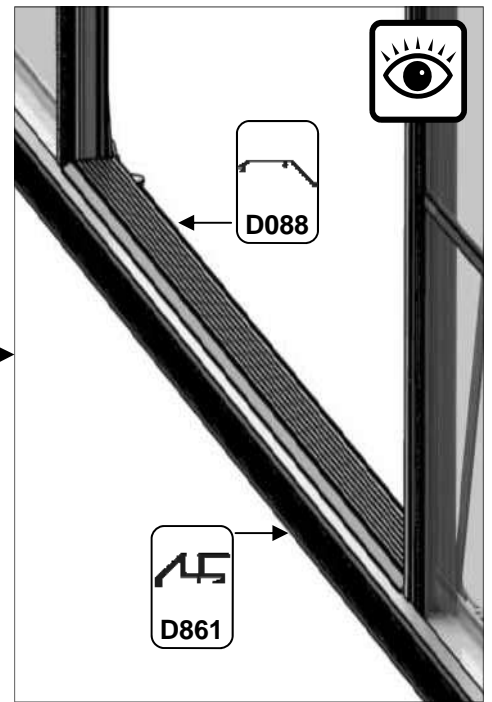
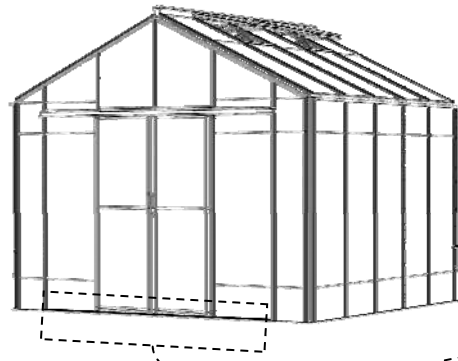

5

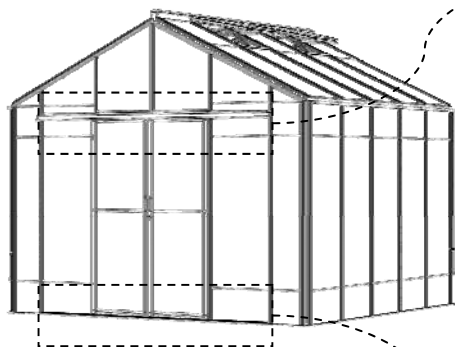
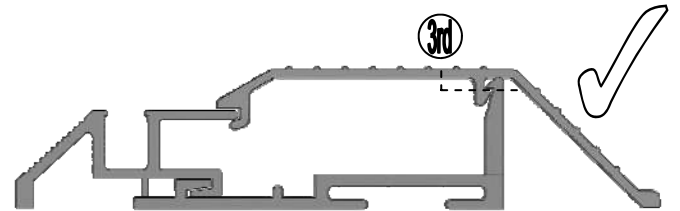
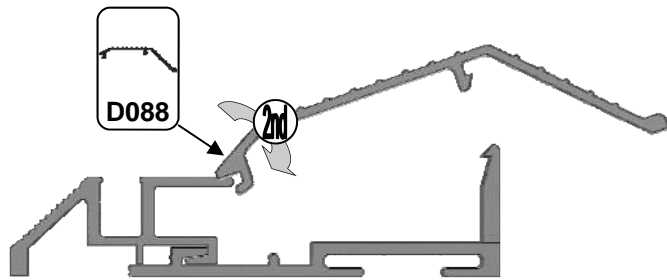
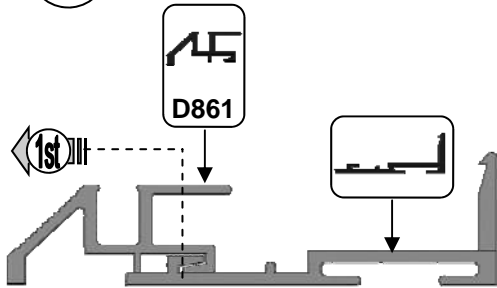

6

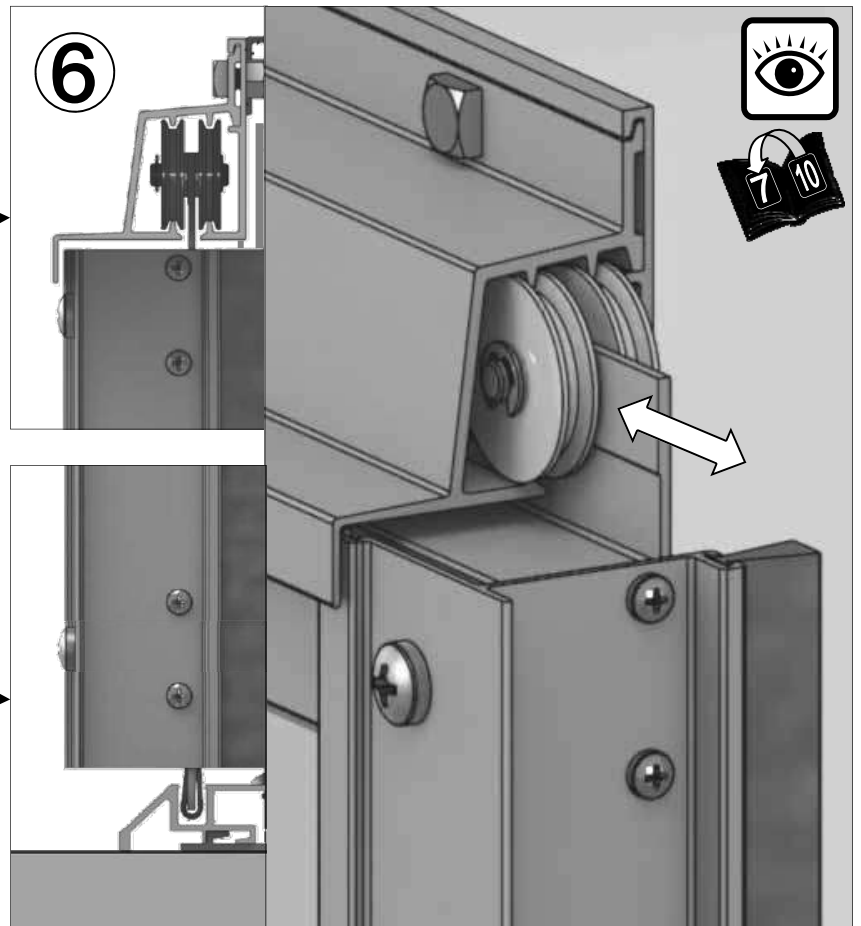

10

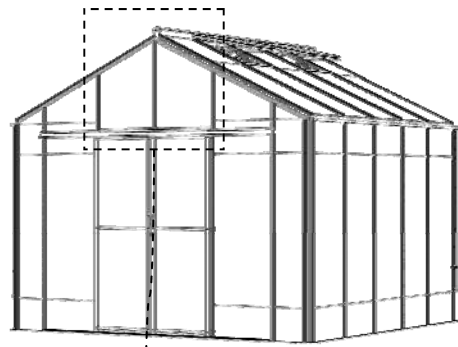
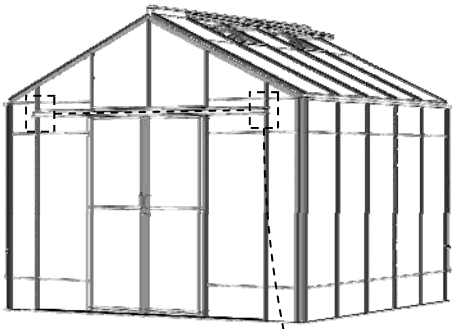

Part No		Quantity
FS6018		2
D312		2
D204L /B		1
D204R /B		1

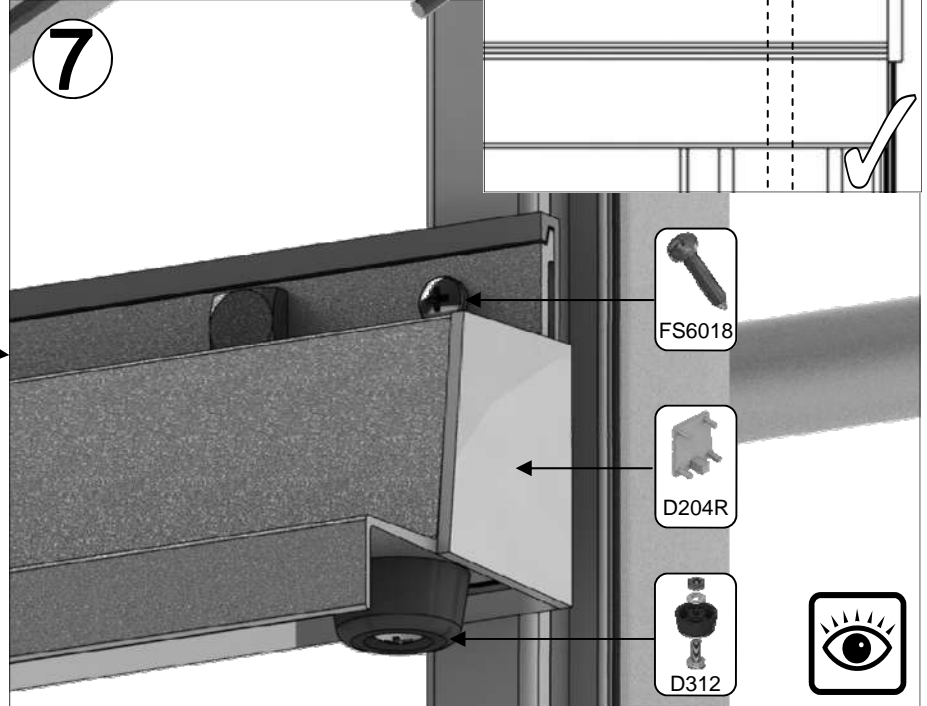
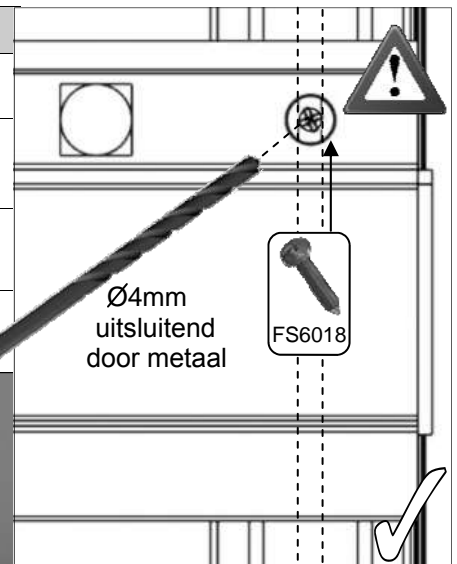

Part No		Q
D745		1
D223/B		1
D748		1
D823		2
D749		2
D833		2

8

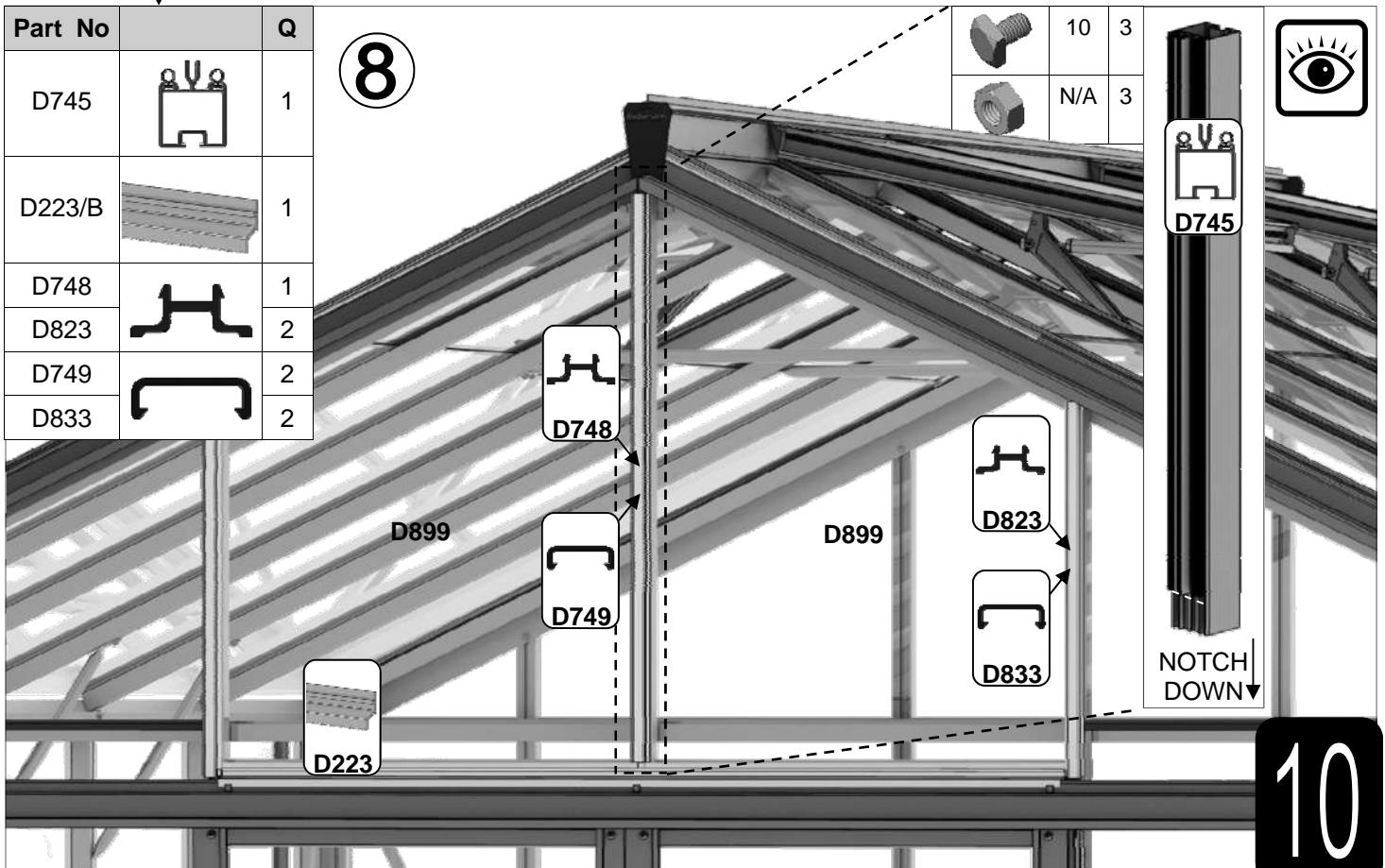

10

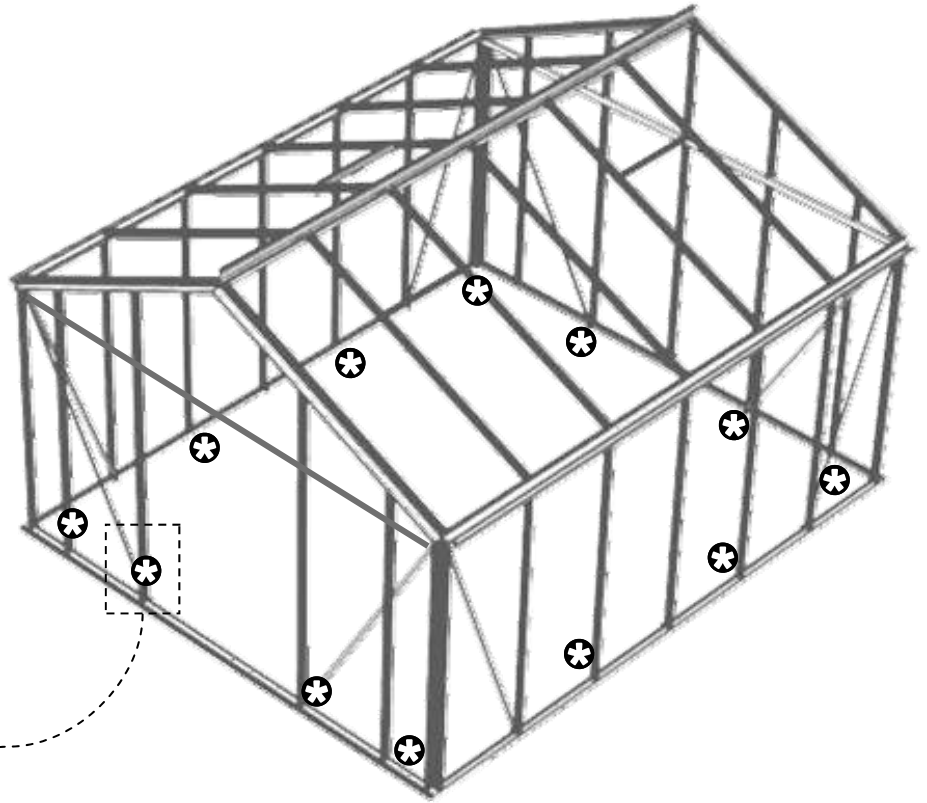
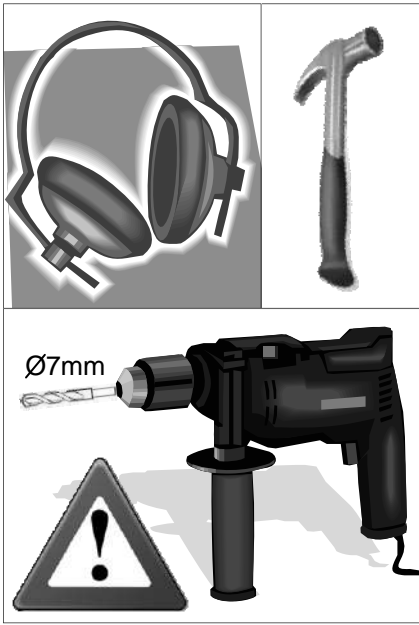

VOORBEELD

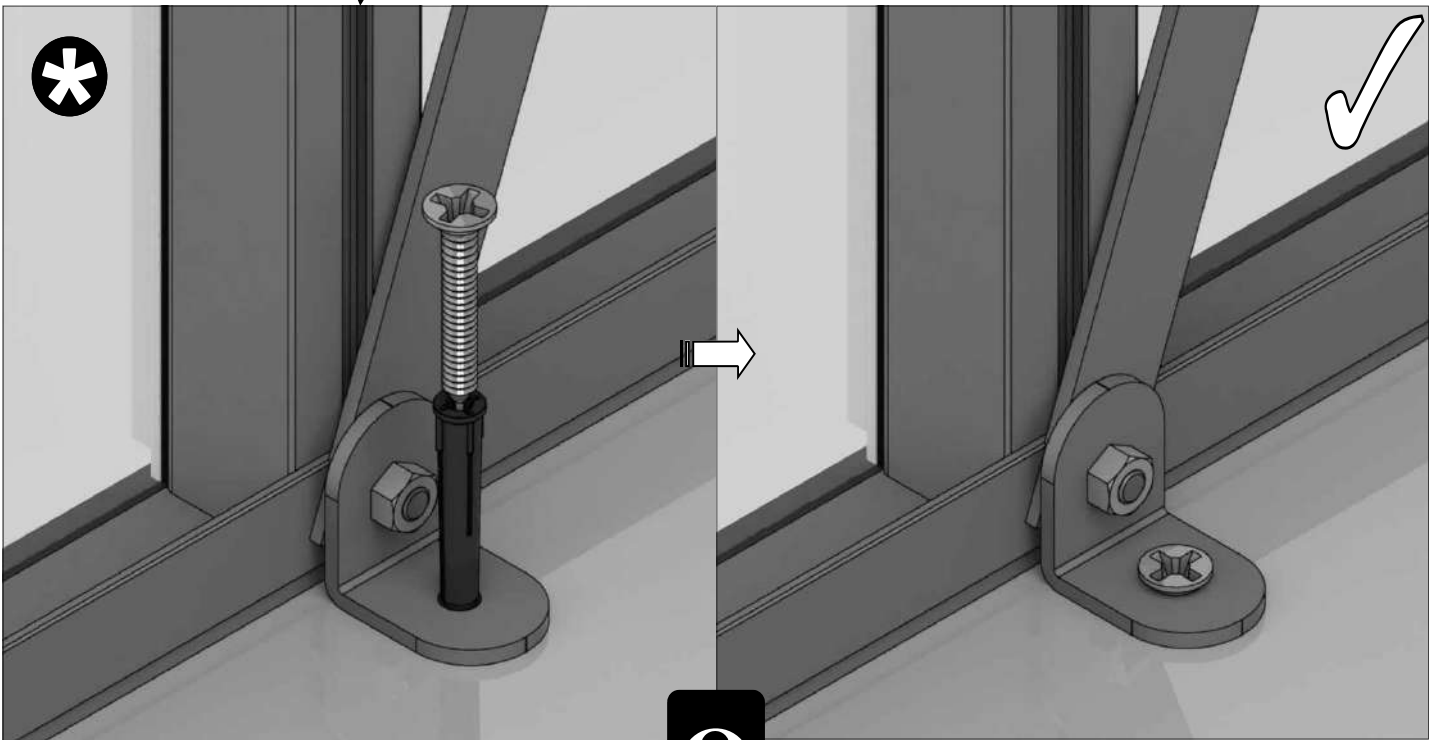

11

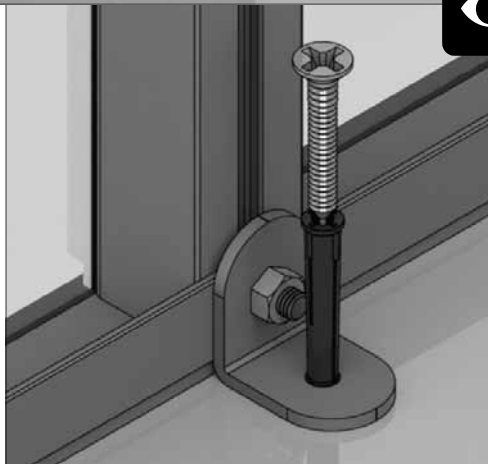



Optioneel lamellenraam = {

Part No		mm	Quantity
D168L		552	1
D168R (handle)		552	1
D165		612	2
D166		552	2
FS6013		12	4

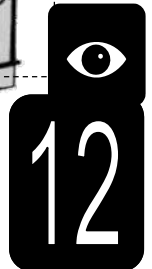
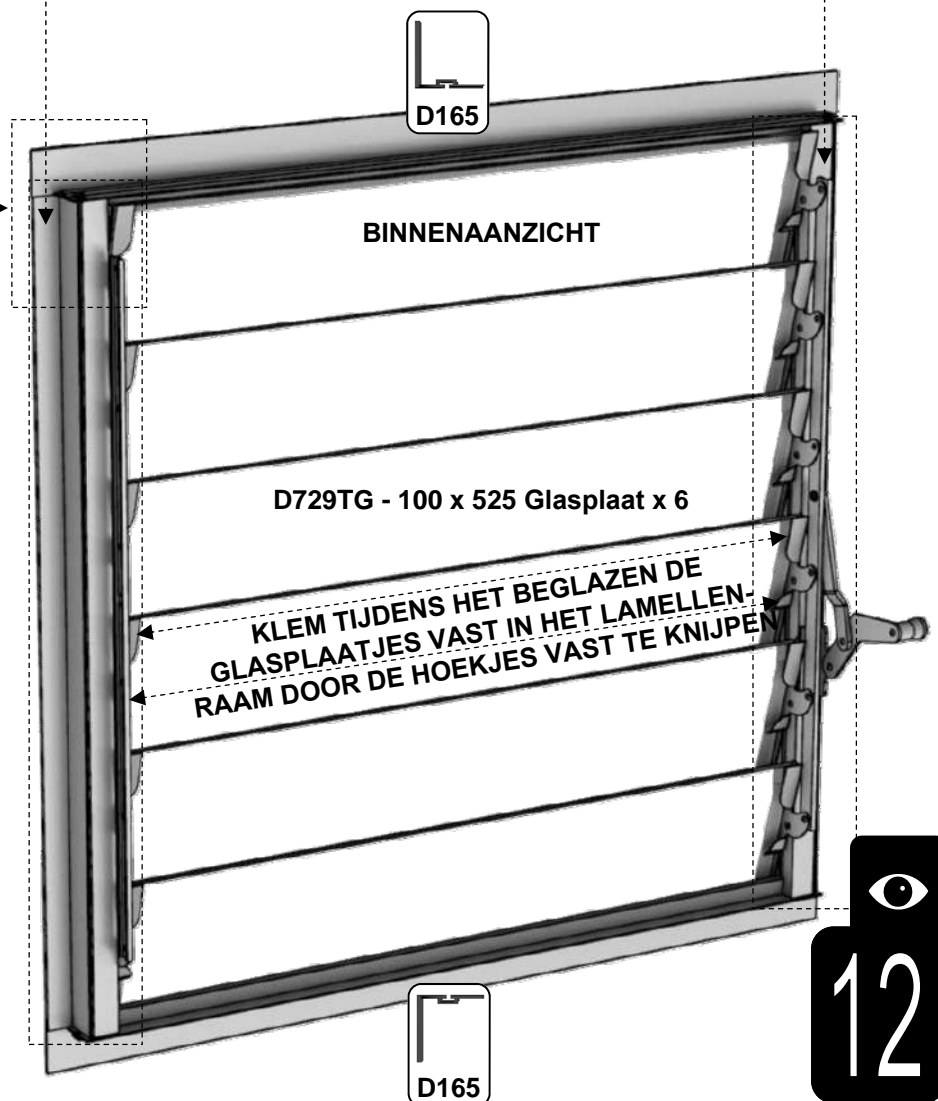
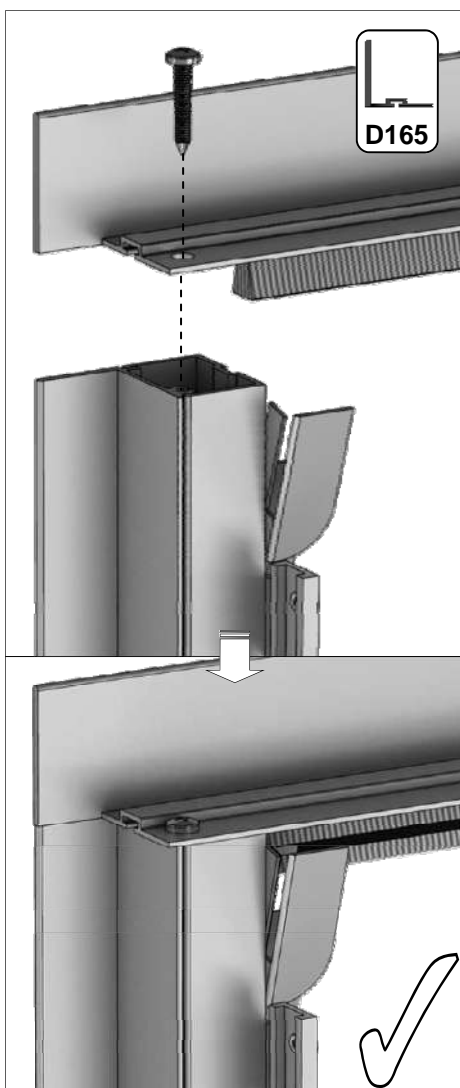
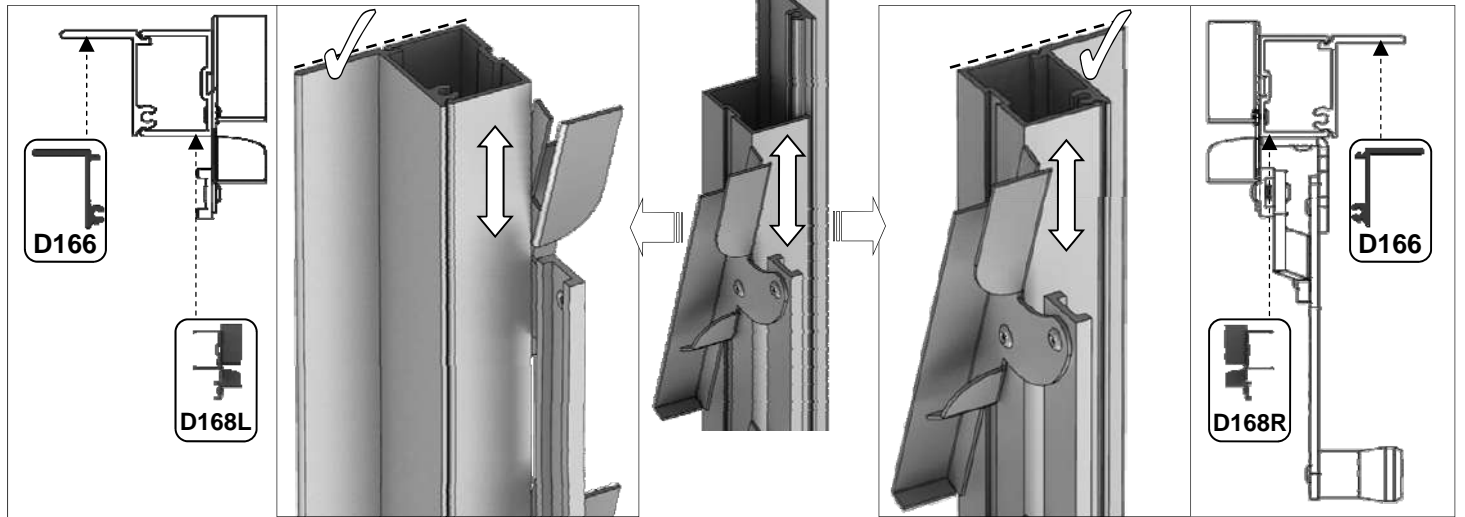

Montage opbergplank (3 latten diep):

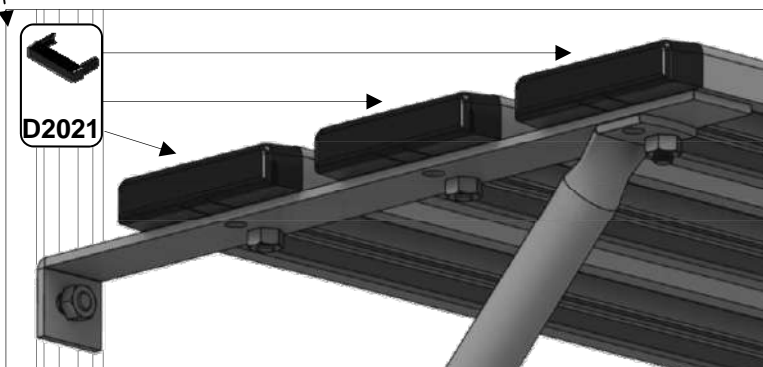
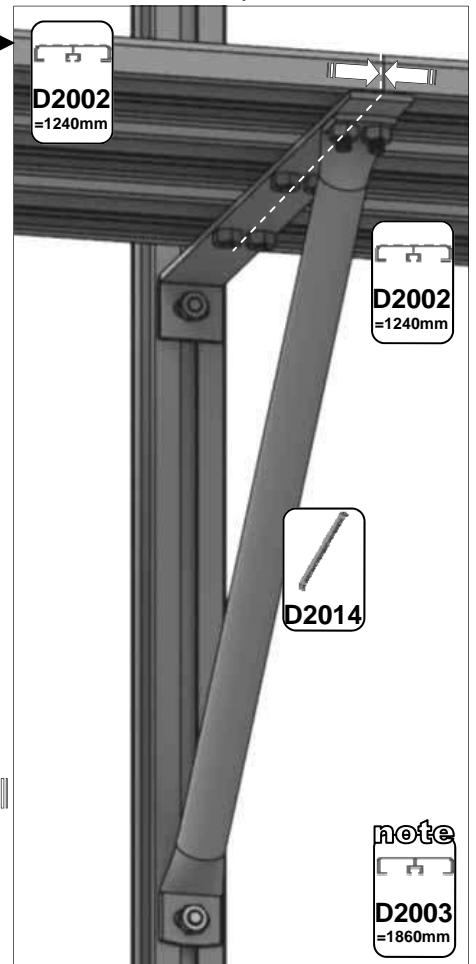
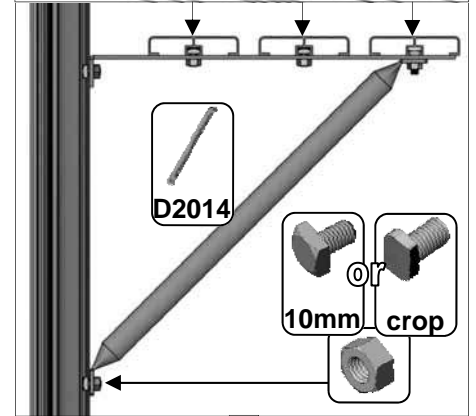
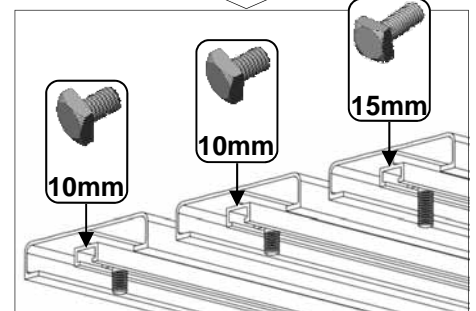
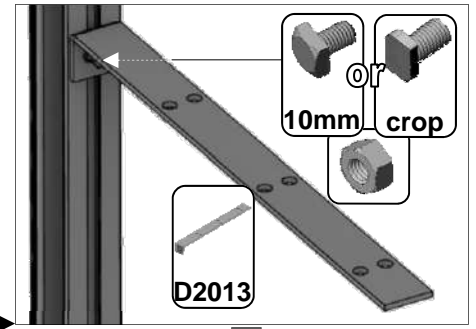
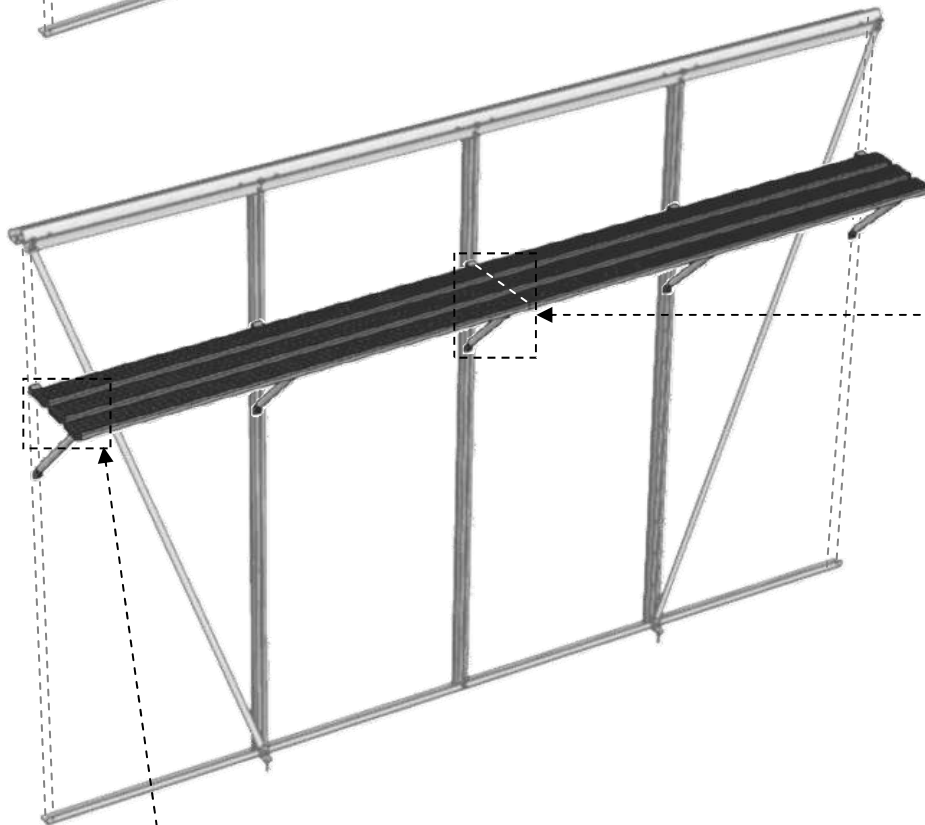
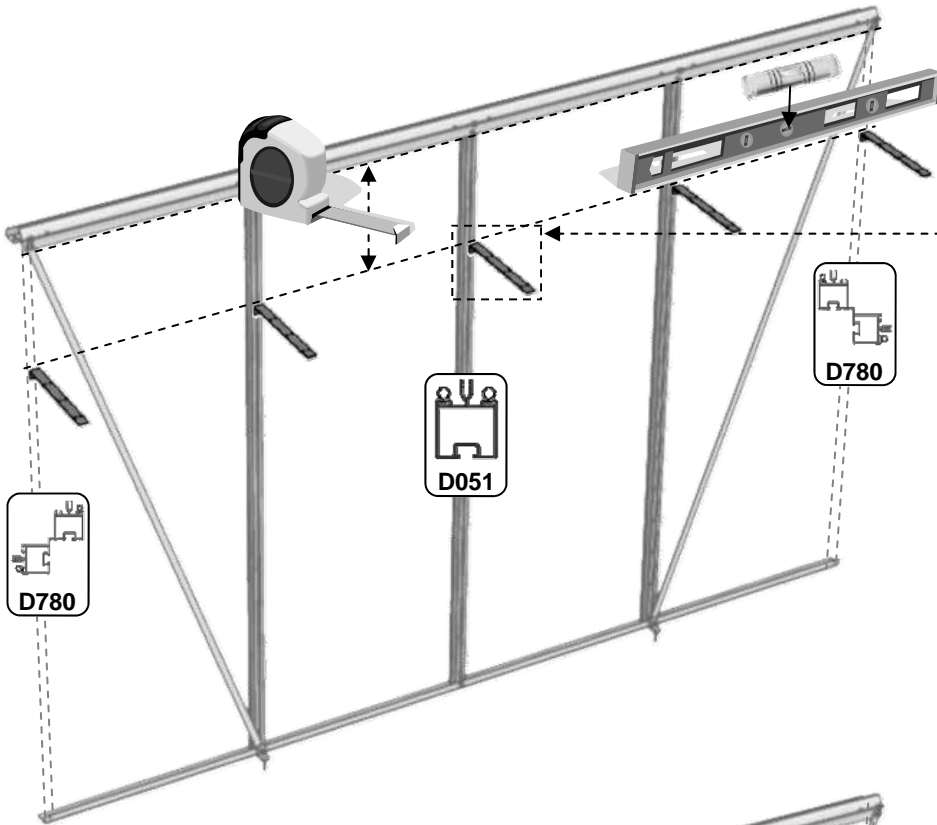

13

Montage werktafel (7 latten deep):

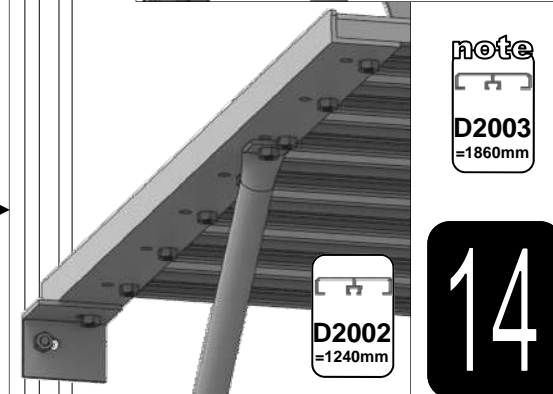
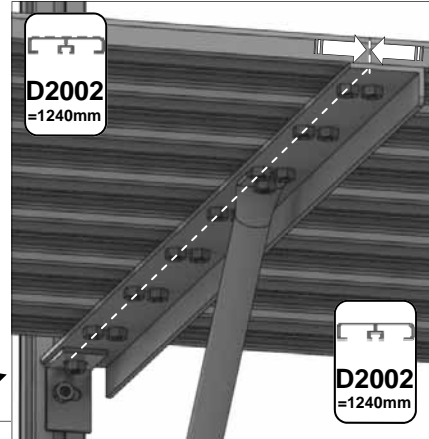
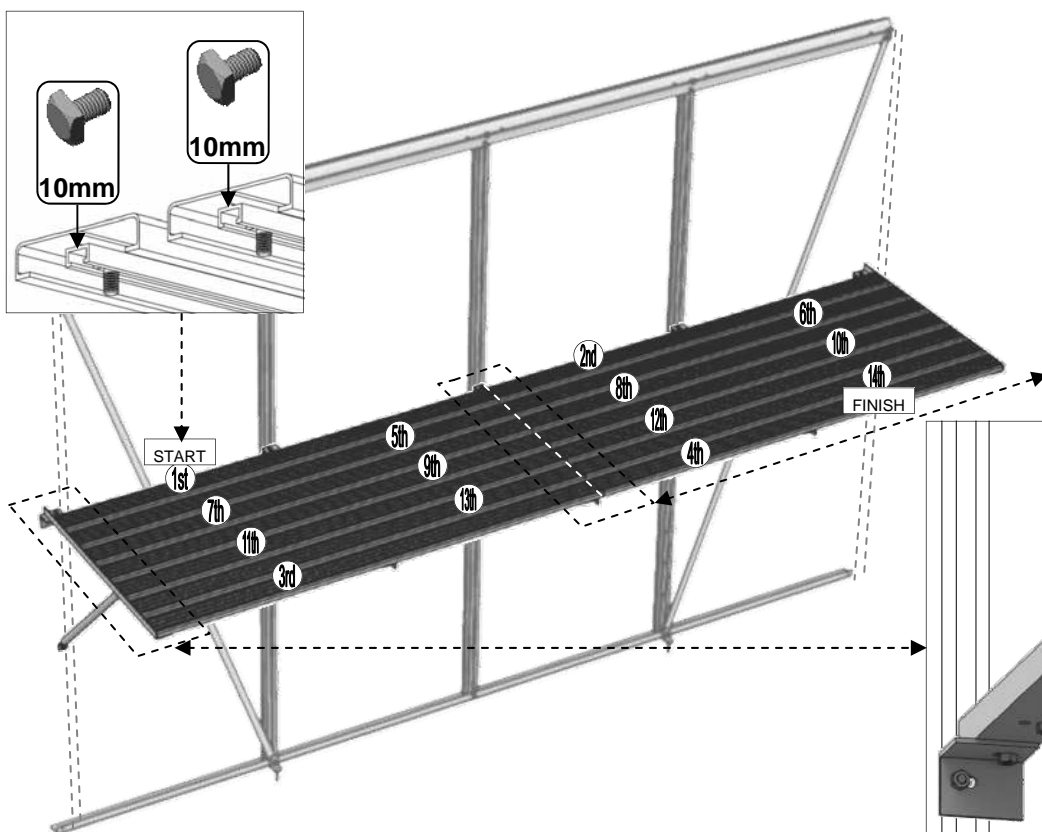
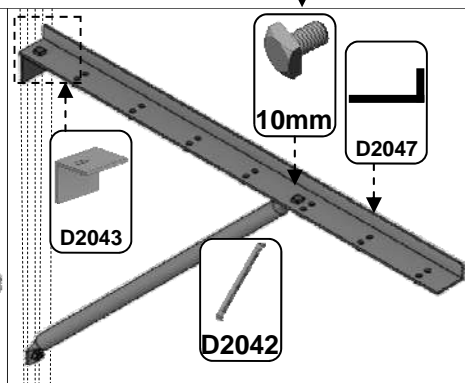
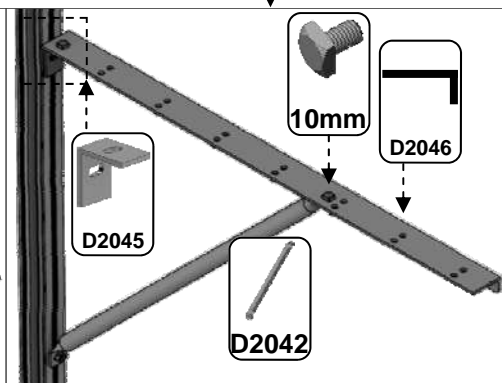
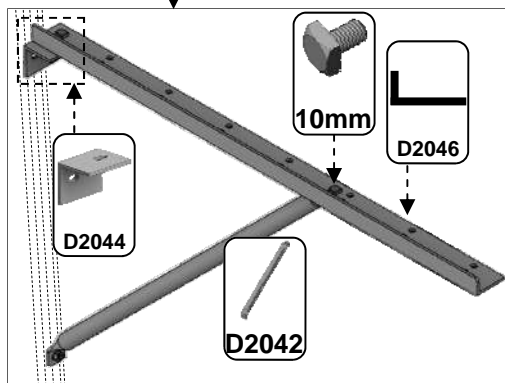
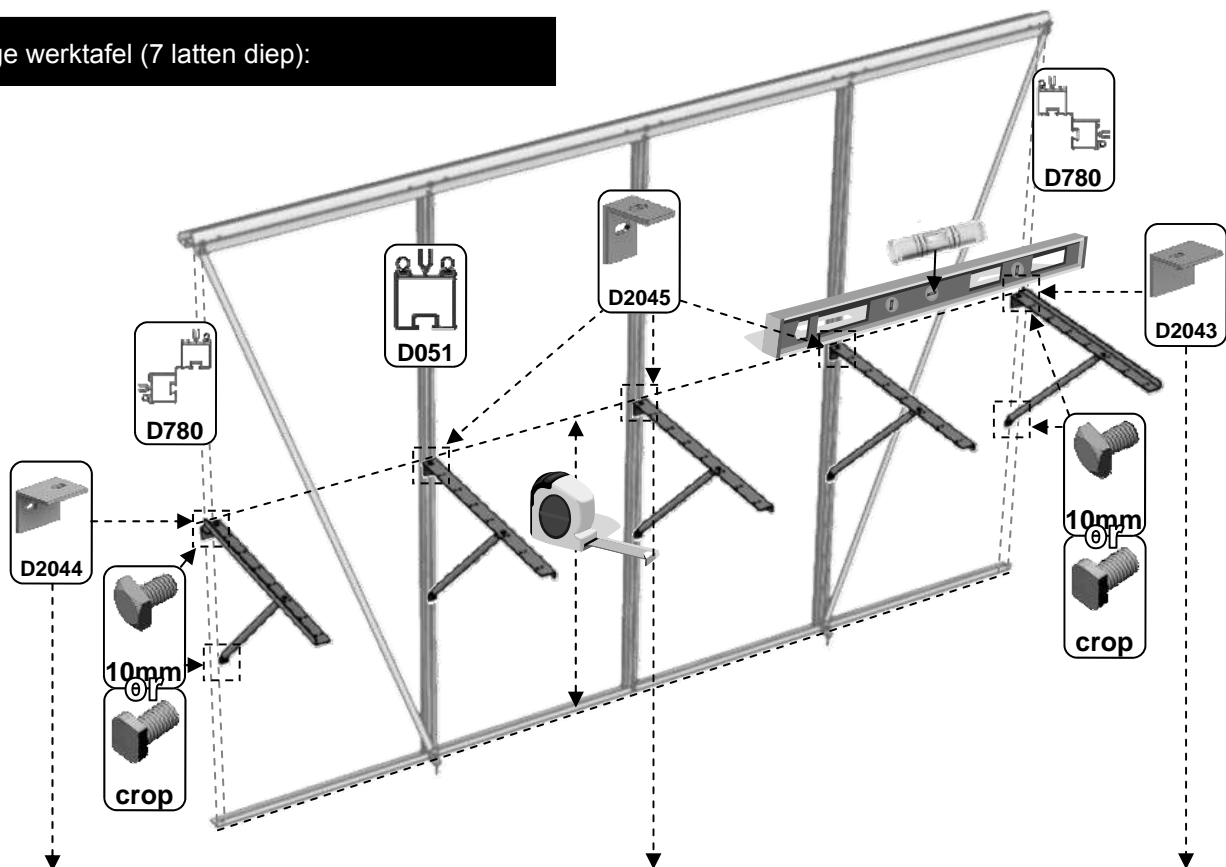

Montage werktafel (10 latten diep):

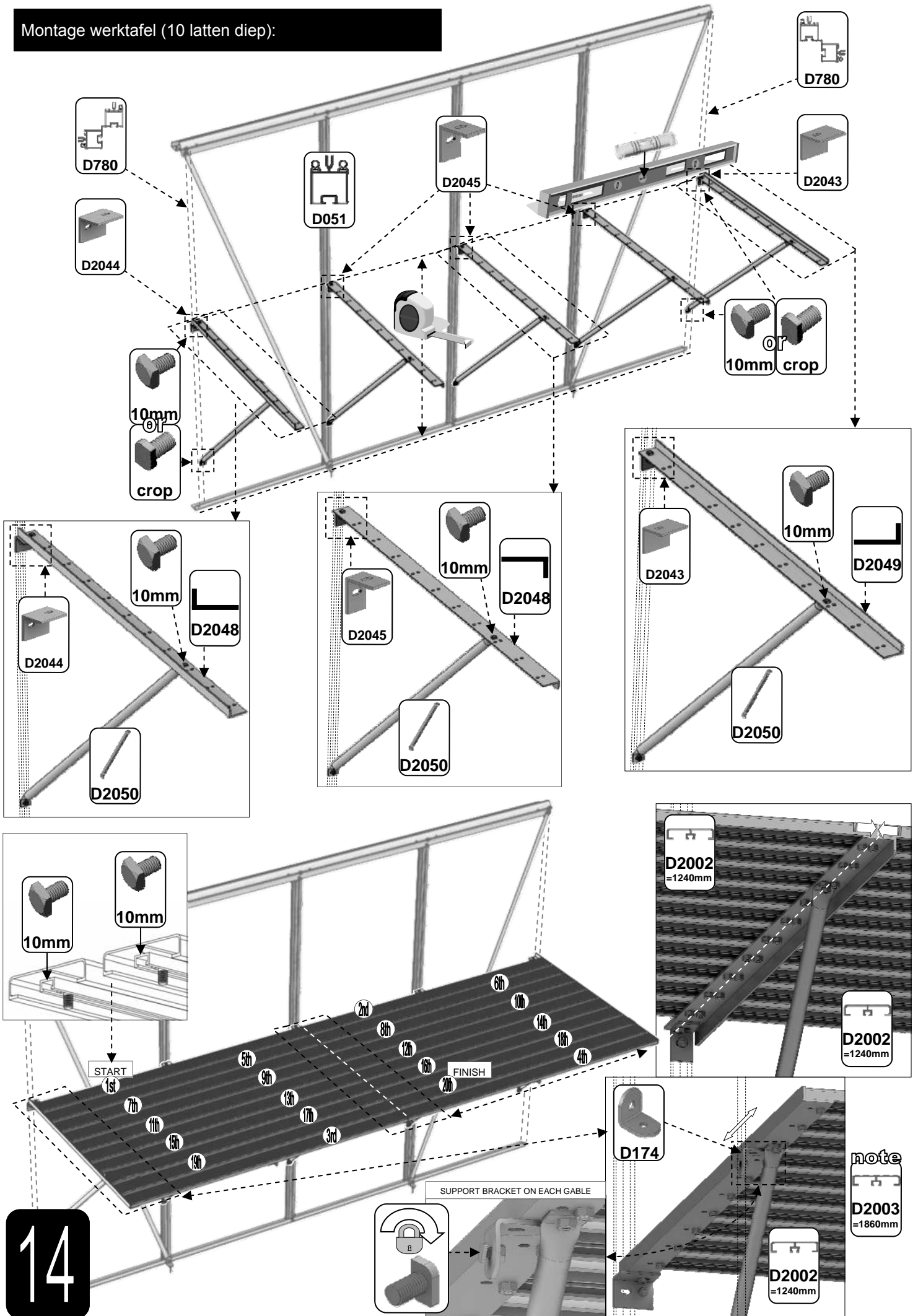

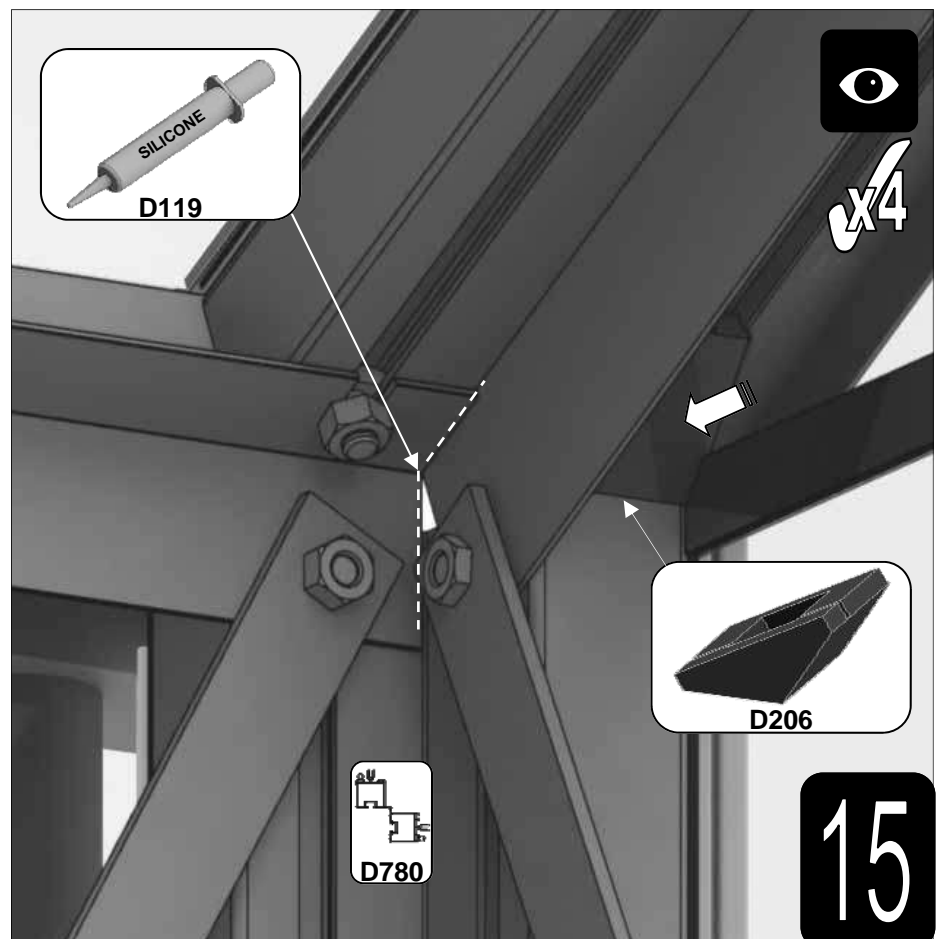
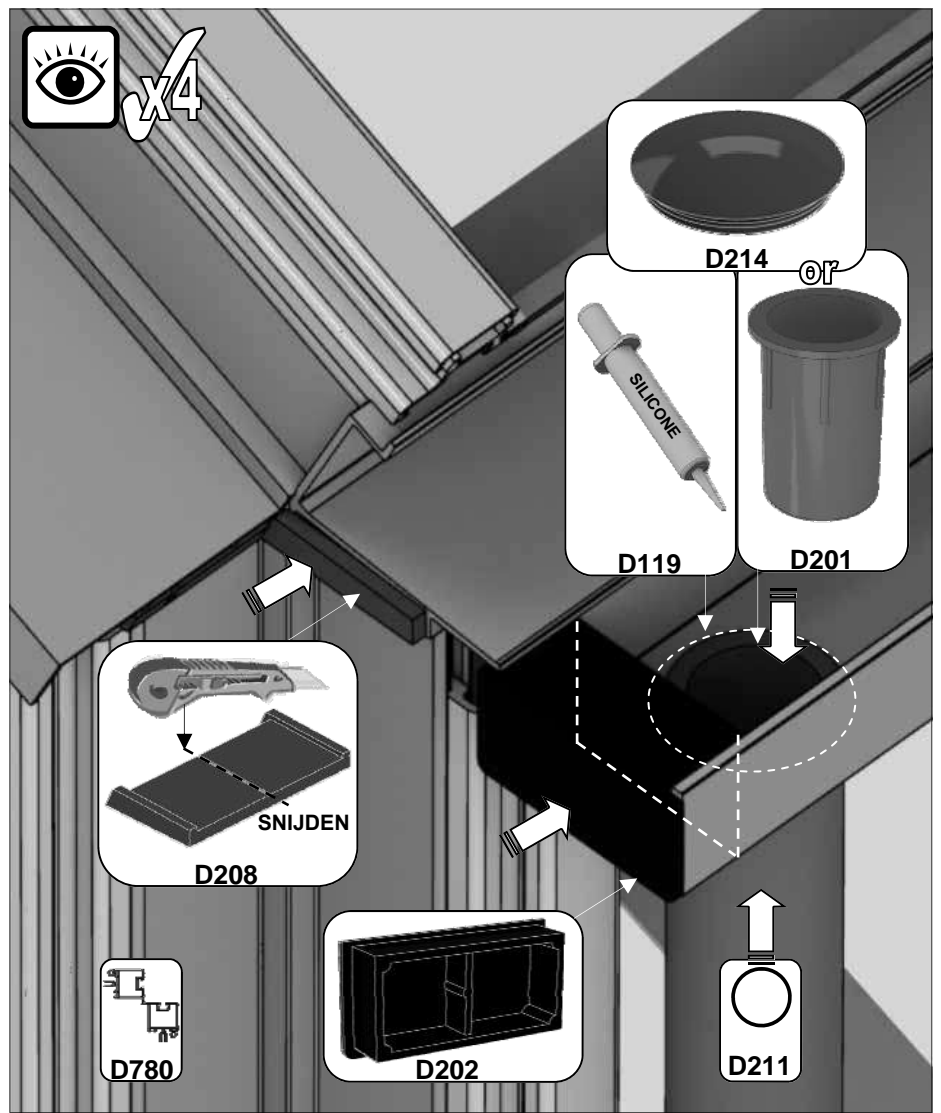
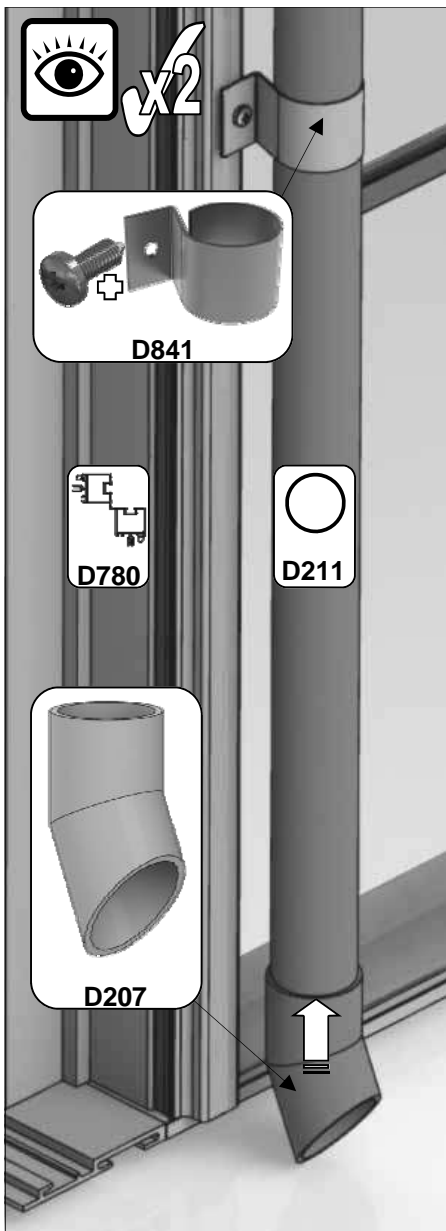
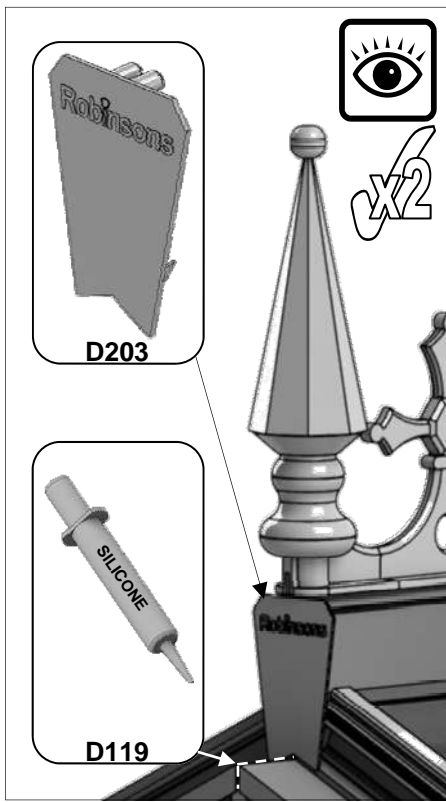

Optionele nokversiering

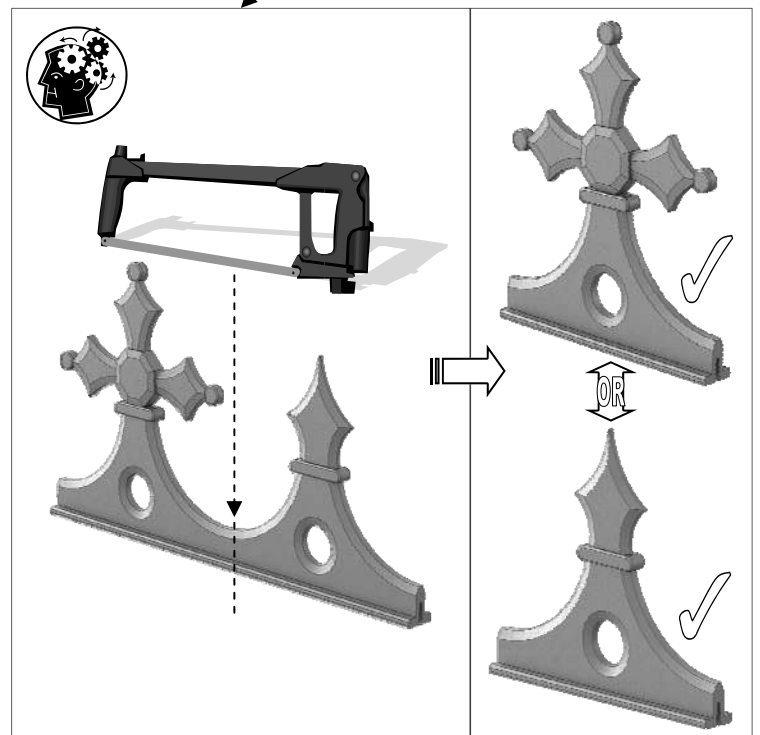
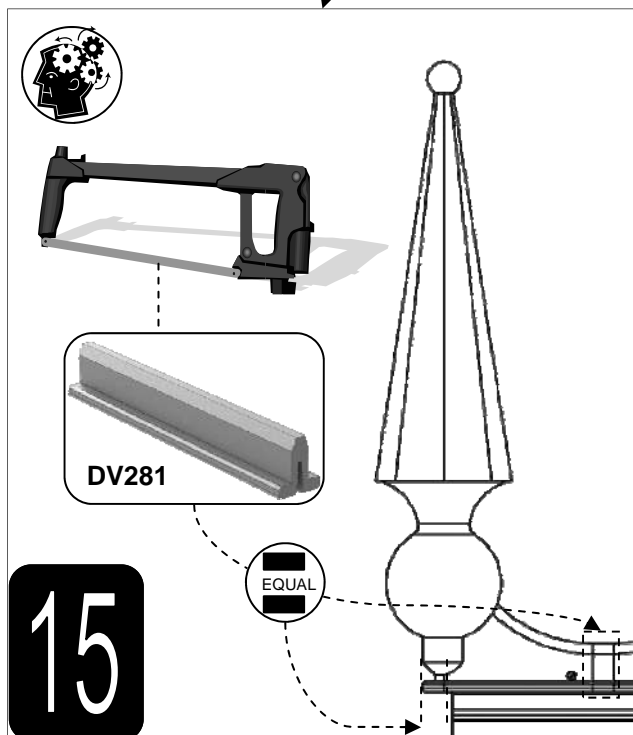
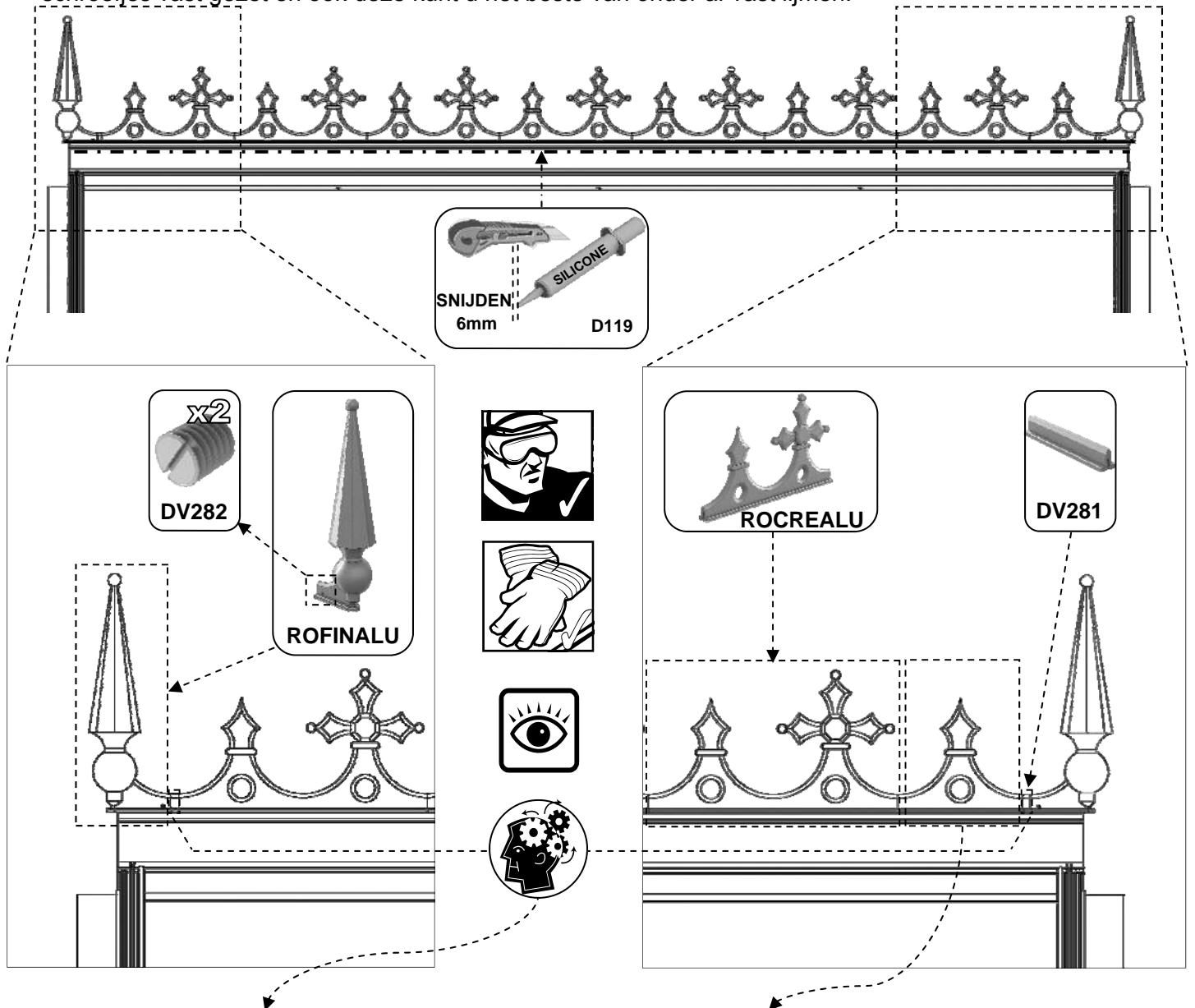

Lijm de nokversiering met een lijmkit vast op de nok. Vrijwel altijd dient u een stuk af te zagen. Gebruik hiervoor een ijzerzaag. De eindstukken worden met kleine schroefjes vast gezet en ook deze kunt u het beste van onder af vast lijmen.





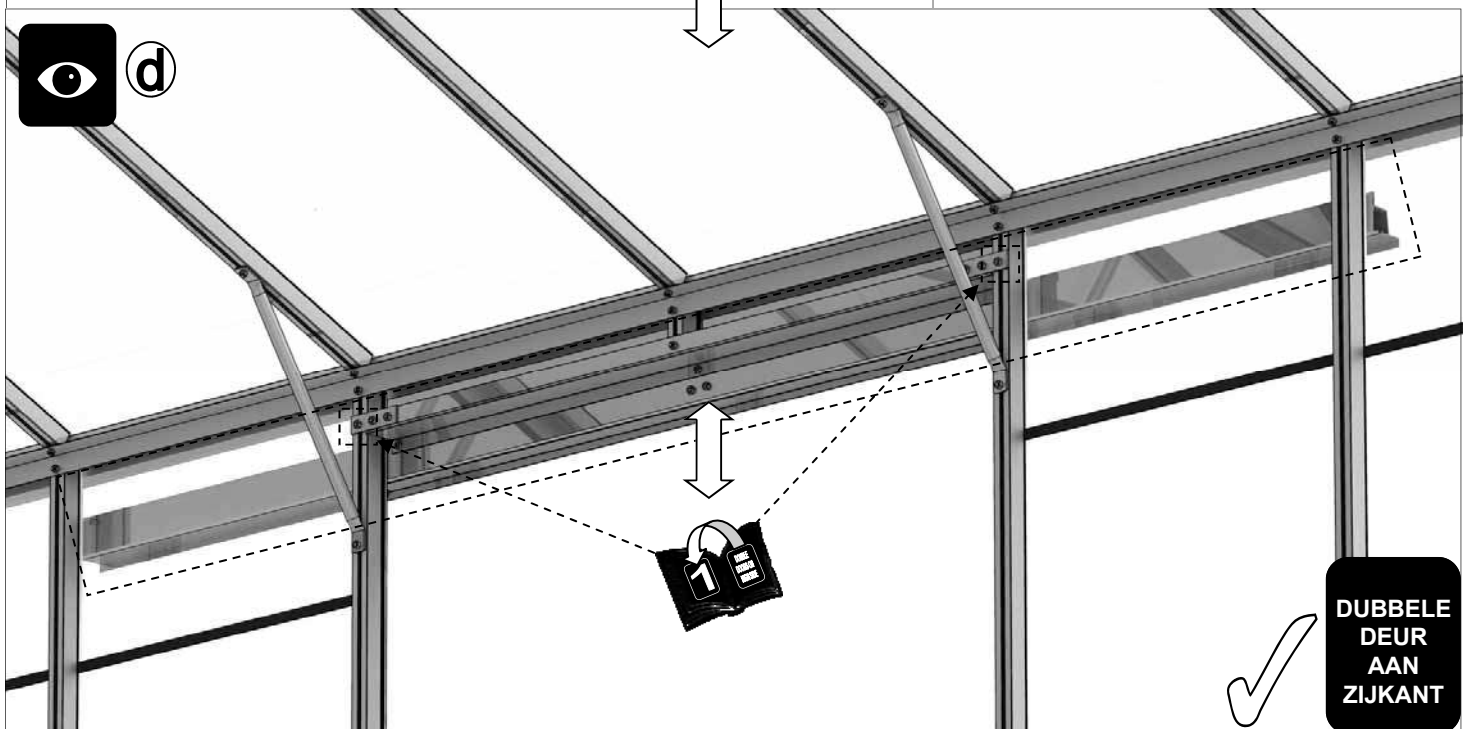
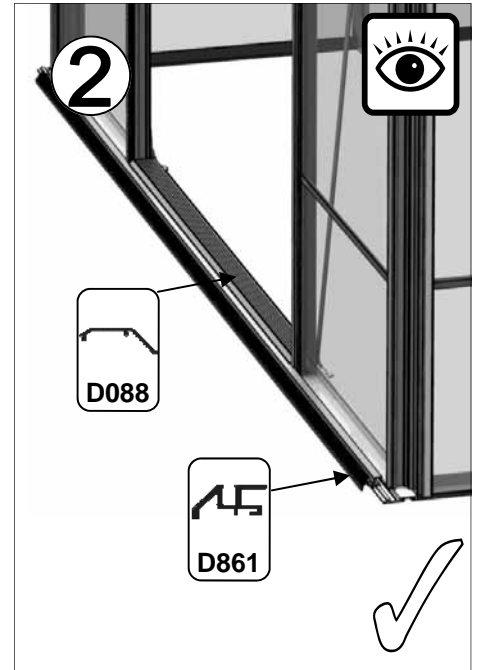
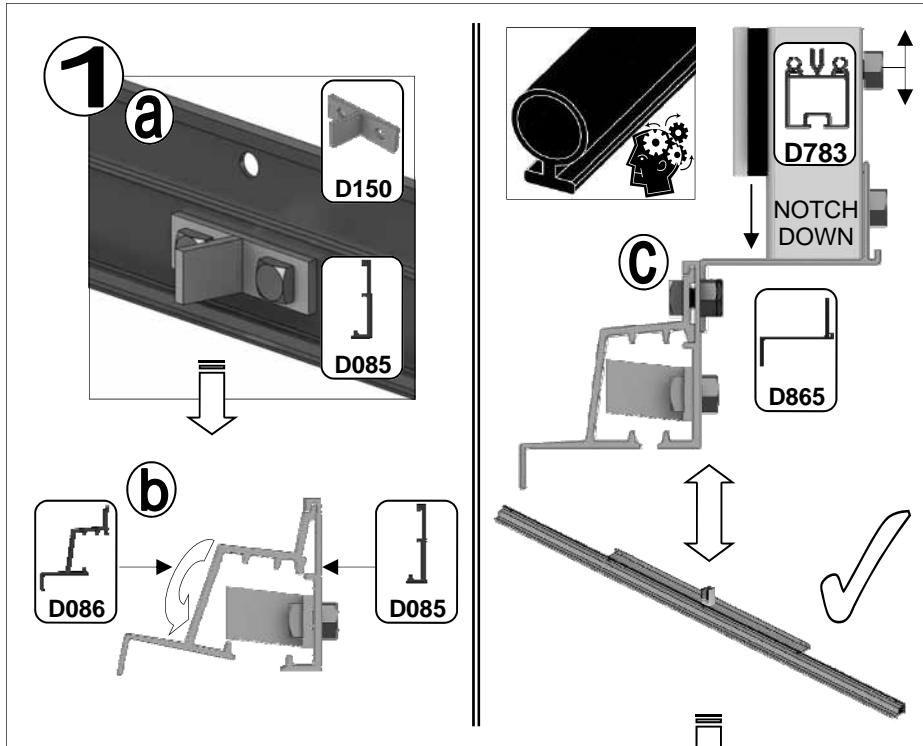
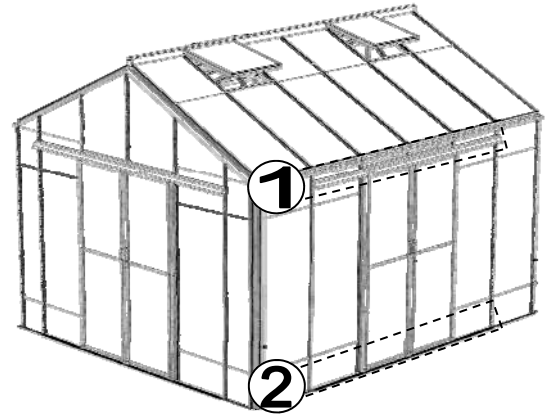

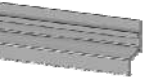
Part No		mm	Q
D865		1210	1
D086		2510	1
D085		2510	1
D861		2450	1
D088		1207	1

Part No		mm	Q
D783		70	1
D163		90	2
D150			1
D845			2
SYBOL M6X15			9
SYNUT M6			9



Part No		mm	Q
D223/B		1210	1
D1060		50	3
D1059		50	3
D920	610 X 58mm PANE OF GLASS		2

Part No		Quantity
FS6018		2
D312		2
D204L/B		1
D204R/B		1

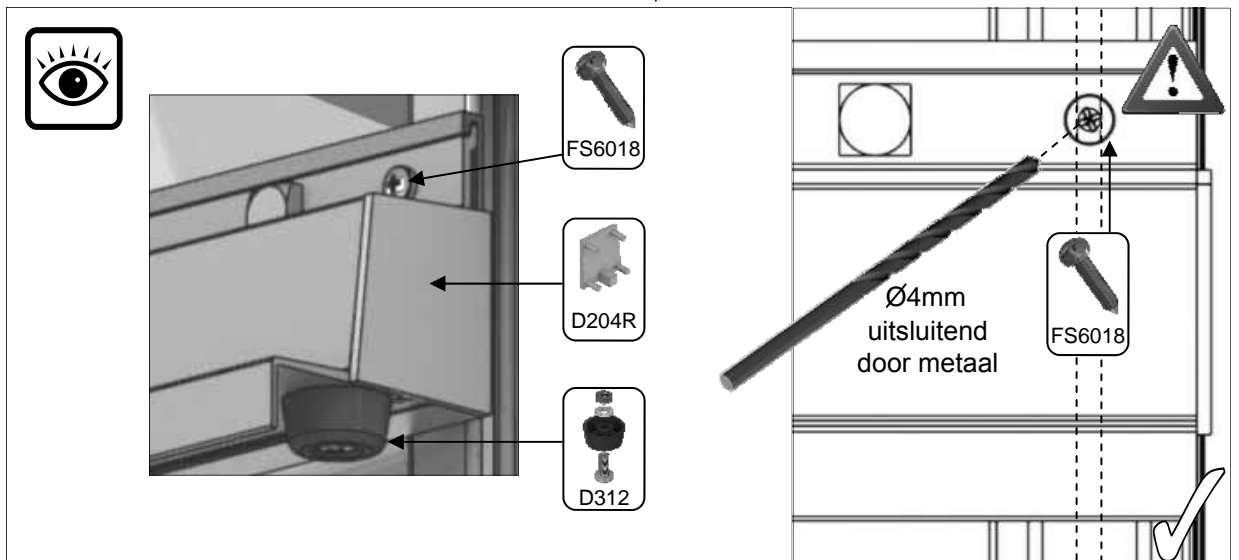
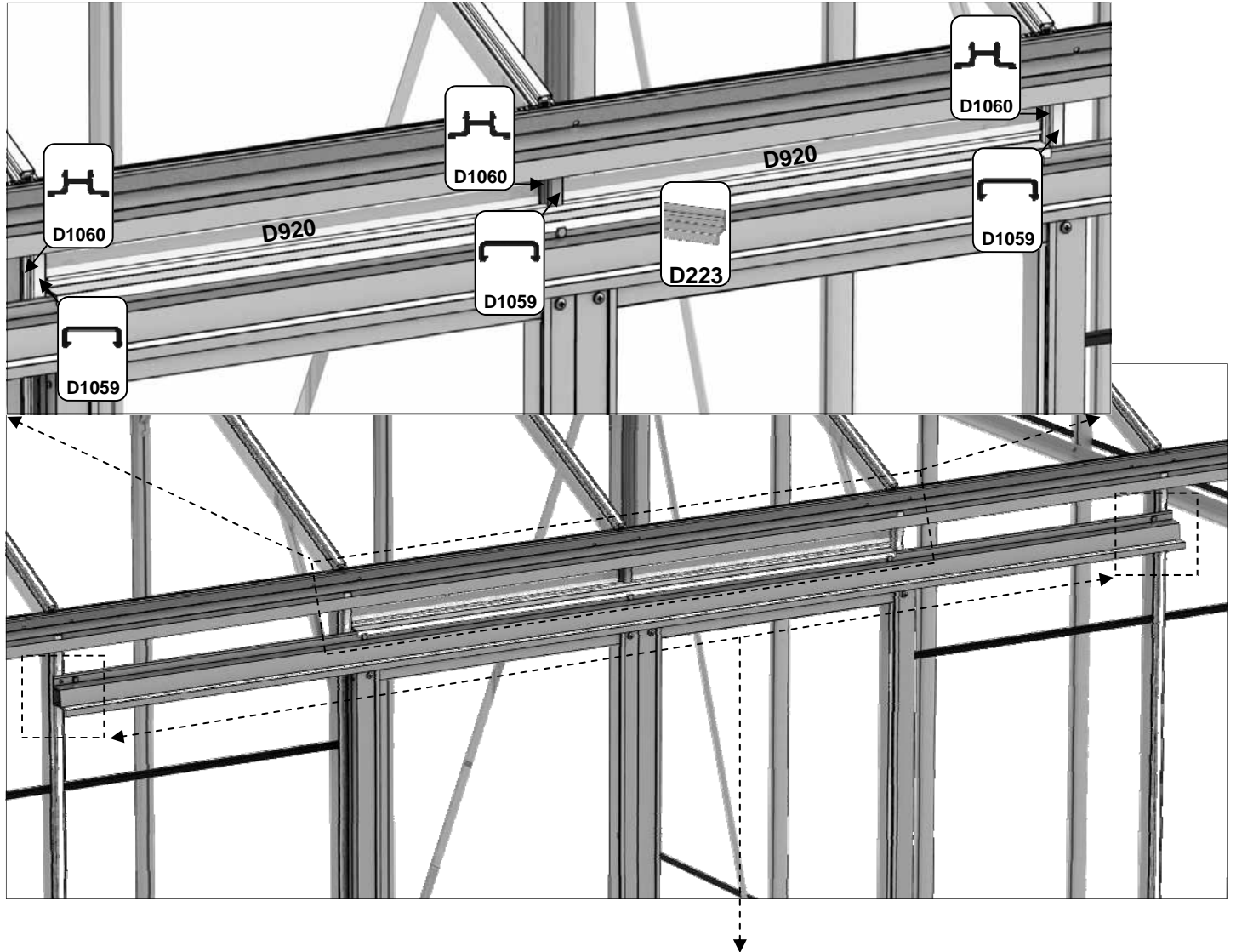
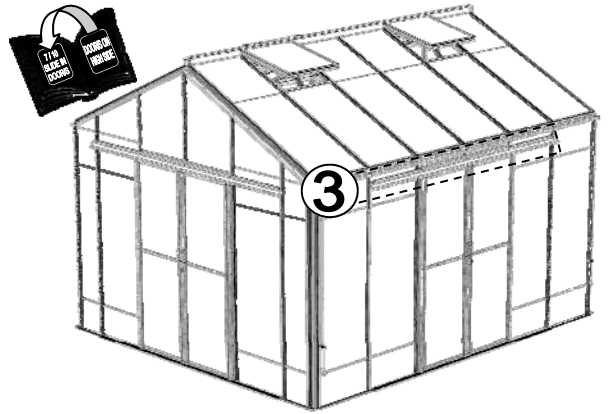

**DUBBELE
DEUR
AAN
ZIJKANT**

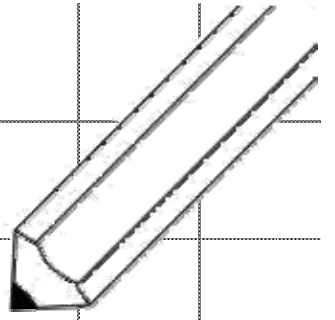

Houd er rekening mee dat dit een multinationale handleiding is. Als u fouten ziet of constructief commentaar heeft, stuur dan een e-mail naar sales@robinsonsgreenhouses.co.uk. Dan zullen de nodige wijzigingen worden aangebracht. Hoewel de informatie in dit boekje accuraat is op het moment van publicatie, is het mogelijk dat veranderingen in de loop van het Robinsons beleid van verbetering door ontwikkeling en ontwerp niet worden aangegeven. Wij wijzen op dit feit om overtredingen van de Wet Handelsbeschrijvingen te voorkomen en ook om te informeren dat Robinsons Greenhouses zich het recht voorbehoudt om specificaties en materialen te wijzigen zonder kennisgeving vooraf.



www.robinsonsgreenhouses.co.uk

To contact Robinsons Customer Services email us at sales@robinsonsgreenhouses.co.uk or call us on 01782 385 409.