

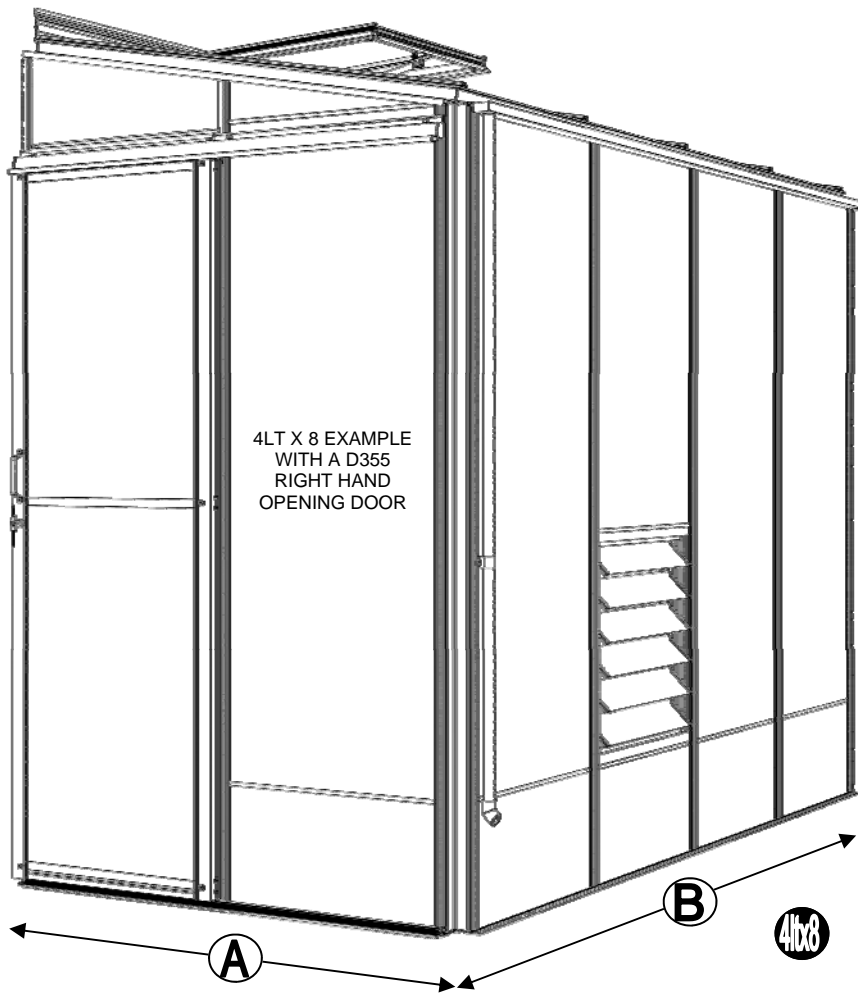

4' Lean-To Assembly Instructions

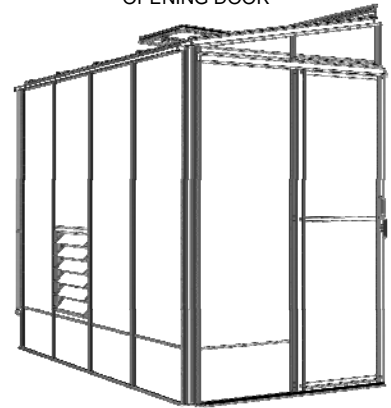

4LT X 8 EXAMPLE
WITH A D356
LEFT HAND
OPENING DOOR



4LT X 8 EXAMPLE
WITH A D550
DOUBLE DOOR

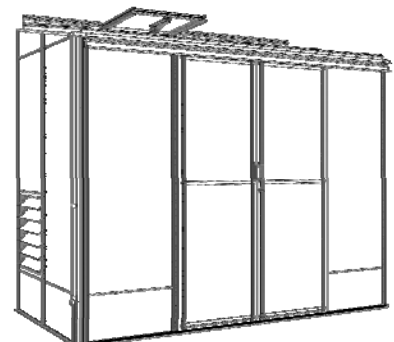

NOMINAL SIZE	A (mm)	B (mm)
4lt x 4	1332	1392
4lt x 6		2012
4lt x 8		2632
4lt x 10		3252
4lt x 12		3872

NOMINAL SIZE	A (mm)	B (mm)
6ft extension	-	1860



Thank you for purchasing your new Robinsons greenhouse. We recommend you familiarise yourself with the instructions and read all safety information before you commence assembly. This instruction manual is also available online at www.robinsonsgreenhouses.co.uk in our technical help section should you need to reprint it. Should you require any additional advice you can always call us on 01782 385409.

These instructions are divided into sections highlighted by a white number/letter on a black background at the bottom corner of most pages (see opposite page for details); **part lists**, **B**-base, **P**-preparation, **1**-side, **2**-front gable, **3**-rear, **4**-joining the three sides together, **5**-roof, **6**-wall attachment, **7**-vent, **8**-door, **9**-glazing, **10**-vent attachment, **11**-door attachment, **12**-anchoring down, **13**-optional louvre, **14**-optional shelf, **15**-optional staging, **16**-finishing touches, **Door / Double doors on the side** (this is optional and needs to be pre-ordered. If you need to contact us for assistance please refer to the relevant section/s. If your building is longer than 12', i.e. has an extension then please also refer the separate extension manual.

Safety Warning

- Glass and aluminium can potentially cause injury. Please ensure you wear protective goggles, gloves, headgear and suitable footwear when assembling and glazing the building.
- Please remember that glass is fragile and should be handled with extreme care. Always clear up and dispose of any breakages immediately.
- Do not assemble the greenhouse in high winds.
- For safety reasons and ease of assembly, we recommend that this greenhouse is assembled by a minimum of two people.
- Please clear all lying snow from the greenhouse roof as it can cause the roof to buckle or collapse.

Site Preparation

- When selecting a site for your greenhouse, it is vital that you choose as flat and level an area as possible.
- A concrete or slabbed base will provide the most solid foundation for your greenhouse.
- IMPORTANT: Do **not** fix your building down until the building is fully assembled, including glazing.
- Avoid placing your greenhouse under trees or in other vulnerable locations.
- To minimise the risk of wind damage, try to select as sheltered a site as possible, e.g. beside a hedgerow or garden fence.

Additional Considerations

- Please bear in mind that assembling your greenhouse can be time consuming. You may need to spread the construction over two or more days. We recommend that you avoid leaving the building partially glazed. If you ever have to leave your greenhouse half assembled and not anchored down, weigh it down with slabs or bags of sand to stop the wind moving it.
- You will find it helpful to prepare a large, clean and clear area in which to work in. A garage floor or flat lawn area is ideal.
- If you have arranged for someone to install your greenhouse for you, please check that all components are included. The components can be identified by their distinctive profiles, lengths and quantities detailed in the parts list (see next page).
- Anchoring down your greenhouse should be the final stage of construction (including glazing).
- Once installed your greenhouse requires little maintenance, but to maintain the smooth running of your door(s) WD40 or similar can be applied to the door wheels and lower door guides.

Guarantee

- Your new Robinsons greenhouse is guaranteed for 10 years against faulty manufacture of the frame-work. This does not include glazing, moving parts, accidental damage or wind damage.

KEY SYMBOL	KEY DESCRIPTION
	EXTERNAL VIEW
	INTERNAL VIEW
	THINK
	THIS SECTION RELATES TO ANOTHER (e.g. 1 to 5)
	CORRECT
	DO NOT FIX DOWN!
	TWIST TO LOCK
	TIGHTEN
	PUSH AND HOLD
	CUT TO LENGTH

UPDATE: Robinsons plastic / aluminium cover strips -

On a Robinsons building the glazing capping is in two parts. The lower plastic capping screws into the glazing bars pressing the glass down onto its rubber beading. The upper plastic / aluminium covers then need to be applied to cover the heads of the self-tapping screws. If you are struggling to press on the cover strips then we recommend the use of a rubber mallet or perhaps a wooden block and hammer, a short sharp tap onto the cover at one end is all that is needed to stretch the cover around the lower capping protrusions locking it into place. You can then either continue to use the mallet along the length of the cover or continue just using the palm of your hand. Once in the building and the edges are protected Robinsons 4mm thick toughened safety glass is very strong and can cope with the vibrations caused by hitting the covers though we would not recommend that you hit the glass directly. Some of the aluminium cover caps have a hole in them at one end which is sometimes used to hang the parts for powder coating. You can if you wish use the hole to stop the covers from sliding in the roof using a glazing screw, note you will have to use a countersunk screw under the vents to avoid interference with the vent bottom.



SECTION No	TITLE	ASSEMBLY SYNOPSIS: IMPORTANT INFORMATION / CONSIDERATIONS
	PARTS LIST	Identify and separate all like for like components prior to assembly. The 'parts list' also separates parts into the various sections 1 - 12 shown below. Parts can also be identified by their profile pictures and stated lengths etc..
B	BASE	Base dimensions and recommendations. Ensure that your base is level as this will make assembly of the building, especially the glazing of the roof much more straight forward.
P	PREPARATION	Tools required. IMPORTANT: Use WD40 or similar in the glazing bar channels and insert the black glazing rubber prior to frame assembly.
1	SIDE	Take the side glazing bars 'D508' with the rubber inserted and the diagonal braces 'D524', use 10mm bolts to join them to the gutter and 15mm bolts to the cills (note how the head of the bolt slides into each glazing bar during construction).
2	FRONT	Again ensuring that the gable framework is rubbered-up follow the diagrams to assemble each end of the building. Make sure that you have inserted the extra bolts utilised in sections 4, 5 and 11. On the roof and side corner bars not every rubber channel will require rubber unless it is to be utilised in a partition (see separate manual and section P).
3	REAR	
4	JOINING THE THREE SIDES	Take the side (1) and both gables (2 & 3) and join them together on your base. It is a good idea to tie some ladders to the side to support them if you do not have anyone to hold them for you.
5	ROOF	Attach the ridge and then the rubbered-up roof bars ensuring that they are fully butted up to the ridge and down onto the gutter. Some tubular braces are supplied to add extra strength, they can be fitted now or later with crop head bolts.
6	WALL ATTACHMENT	The main body of the frame is complete it can be attached to the wall. Make sure that the wall bars are vertical and the ridge is horizontal then drill and screw the building to the wall. Do not attach the base to the ground until section (12) as your building may not be square.
7a	VENT	Once the vent is glazed add silicone to the vent sides and top. Stand the vent/s on their hinge (vent top) and then leave the silicone to set.
7b	VENT SLAM	The slam bar 'D079' can be moved up and down between the roof glazing bars so that it can be butted down onto the pane of glass beneath, the autovent will be attached to it later on (10).
8	DOOR/S	Construct the door using the diagrams and then leave to one side ready for attachment in section (11). Double Doors on the side detail is shown right at the back of the manual, pages 37 onwards.
9	GLAZING	Layout the bar cappings and covers around the building like a sundial checking that all is present and correct. You can also place the roof cappings in the gutters so they are closer to hand. The glass in the sides has to bevel on the black separator strip which is on top of the 305mm high glass base panels. This bevelling action allows the glass to tuck underneath the gutter canopy. Use the capping and the self tapping screws to then hold the glass in place. The covers then enclose the screw heads giving a neat finish. A top tip is to not attach the door post capping (D814/D836) until you have fitted the door runner and threshold (11) to give you more room to manoeuvre.
10	VENT ATTACHMENT	Take the assembled vent and slide the vent hinge 'D866' into the end of the ridge allowing the vent the pivot open and closed. Vent stops go either side of the vent to stop any lateral movement (so insert stop / vent / stop). Attachment of the Bayliss XL autovents.
11	DOOR ATTACHMENT	Use the bolts inserted in section (2) to attach the upper door track. The lower door runner 'D860' and ramp threshold 'D087' push down and lock together. Please note that if you are putting the door on the left hand gable (as you look at wall) the door track and runner will go from the doorway towards the gutter and if you are putting the door on the right hand end the track and runner will open towards the wall. Parts D845 act as a lateral spacer, stopping the door track from bevelling out of vertical, they ensure the door/s run smoothly. Some parts in your door pack will be redundant, they are utilised on other models.
12	ANCHORING DOWN	Now that the greenhouse is finished and the door and vent/s are operating without interference then you need to anchor the building down using 2" rawl plugs and screws. Use a 7mm masonry bit in a hammer drill to create the holes.
13	OPTIONAL LOUVRE	They attach to the building during the glazing process (9) like a piece of glass with a black separator above and below them.
14	OPTIONAL SHELVING	Robinsons integral cantilever staging and shelving attaches to the inside of the greenhouse frame using either square head bolts (insert four into each side glazing bar 'D508' during construction of the sides (1)) or rectangular 'crop head' bolts which can be fitted retrospectively (both sets of bolts accompany the shelving/staging). This system allows the height of either the staging or the shelf to be set at an operator specific height. Commonly the staging brackets are set 900mm from the cills though you can alter this to suit the end user/s. The aluminium shelf / staging slats come in two lengths; (4'):1240mm 'D2002' and (6'):1860mm 'D2003'. These slats can combine to create any length of staging required, i.e. 4'+6' = 10' etc...
15	OPTIONAL STAGING	
16	FINISHING TOUCHES	Now that the main body of the structure is complete you can add; downpipe fittings, eave bungs.

Section Ref	Part No.	Section	Size (mm)	4lt 4	4lt 6	4lt 8	4lt 10	4lt 12	Section Ref	Part No.	Section	Size (mm)	4lt 4	4lt 6	4lt 8	4lt 10	4lt 12
-------------	----------	---------	-----------	-------	-------	-------	--------	--------	-------------	----------	---------	-----------	-------	-------	-------	--------	--------

1	D600		1270	1					
	D036		1890		1				
	D037		2510			1			
	D050		3130				1		
	D040		3750					1	
	D947		1277	1					
	D975		1897		1				
	D974		2517			1			
	D979		3137				1		
	D978		3757					1	
	D524		2026	1	2				
	D508		1930	1	2	3	4	5	
RUBBER		1000 (1m)	4	8	12	16	20		
D174		N/A	1	2	2	4	4		

2 + 3	D600		1270	2				
	D510		1930	2				
	D955		2037	2				
	D956		2147	2				
	D653		1270	1				
	D940		1286	2				
	RUBBER		1000 (1m)	28				
	D174		N/A	6				

5	D948		1277	1				
	D976		1897		1			
	D973		2517			1		
	D981		3137				1	
	D977		3757					1
	D942		1286	1	2	3	4	5
	RUBBER		1000 (1m)	3	6	8	11	13

7	D866		639	1			2	
	D863L		613	1			2	
	D863R		613	1			2	
	D862		593	1			2	
	D079 PLUS FLUFF		590	1			2	
	D114		N/A	2			4	
	D220 PLUS FS6060 SCREW		N/A	2			4	
	D205		N/A	2			4	



Section Ref	Part No.	Section	Size (mm)	4lt 4	4lt 6	4lt 8	4lt 10	4lt 12
-------------	----------	---------	-----------	-------	-------	-------	--------	--------

Section Ref	Part No.	Section	Size (mm)	4lt 4	4lt 6	4lt 8	4lt 10	4lt 12
-------------	----------	---------	-----------	-------	-------	-------	--------	--------

8	Right hand opening door D090 + D347 lock = D301		1824			1		
	Left hand opening door D091 + D347 lock = D302		1824			1		
	Right hand opening door D094		1824			1		
	Left hand opening door D093		1824			1		
	D096 + D217 wheel = D307		611			1		
	D095		611			1		
	D097		611			1		
	D232		905			2		
	D233		797			2		
	P053		N/A			1		
	D225		610			1		
	D840B		4000			1		

9	5	D944		1294	1	2	3	4	5
	1	D953		1923	1	2	3	4	5
	3	D913		2030	1				
	3	D960		2140	1				
	2	D969		140	1				
	2	D971		250	1				
	5	D943		1294	2				
	2	D814		1883	2				
	1/2/3	D952		1923	4				
	5	D945		1294	3	4	5	6	7
	2	D836		1883	2				
	3	D914		2030	1				
1/2/3	D954	1923		5	6	7	8	9	
3	D959	2140		1					
2	D970	140		1					
2	D972	250	1						

MAIN FRAME QUANTITIES VENTS / DOORS etc SEPERATE		10mm	13	16	19	22	25
		15mm	26	28	29	30	31
		m6	39	48	54	60	66
		10mm crop	2	4	6	8	10

4' lean to

11	D864		590	1				
	D860		1240	1				
	D087		587	1				
	D084		1270	1				
	D083		1270	1				
	D153		198	1				
	D163		90	2				
	D154		N/A	1				
	D222/B		590	1				
	D112		650	1				
	D845		N/A	2				
	D842		N/A	1				

THE DIMENSIONS BELOW ARE THE EXACT EXTERNAL BASE DIMENSIONS FOR THE ROBINSONS RANGE.

We cannot emphasize how important it is to have a proper base for your Robinsons Greenhouse to be erected upon.

It is essential that the **BASE IS FLAT, LEVEL AND SQUARE AS WELL AS BEING SUBSTANTIAL** enough to take the weight of the greenhouse including its 4mm glass.

Give yourself enough room around your base to allow for fitting the glass and any on-going maintenance / cleaning. A slab base which is larger than the greenhouse is the ideal solution and is our preferred foundation.

A brick perimeter base is equally suitable providing there is a concrete foundation beneath it. We suggest using a solid brick with no frogs or holes (quality stock bricks or semi-engineering bricks).

IMPORTANT: Do not anchor your greenhouse down until it is fully assembled including glazing unless you are 100% sure your base is square and level. If not your glass will not fit properly.

IMPORTANT: If you have anything overhanging the ridge on a lean-to building then please make sure it does not interfere with the motion of the roof vents.

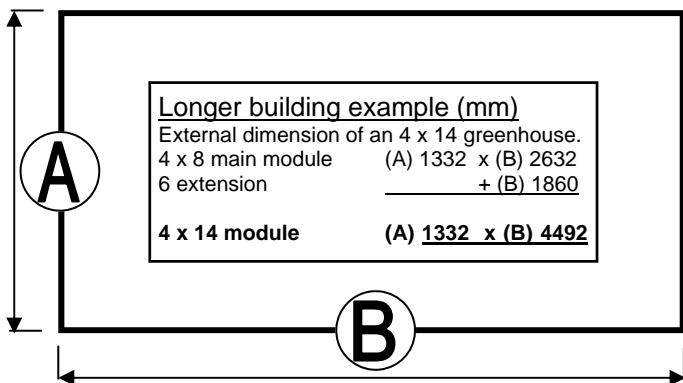
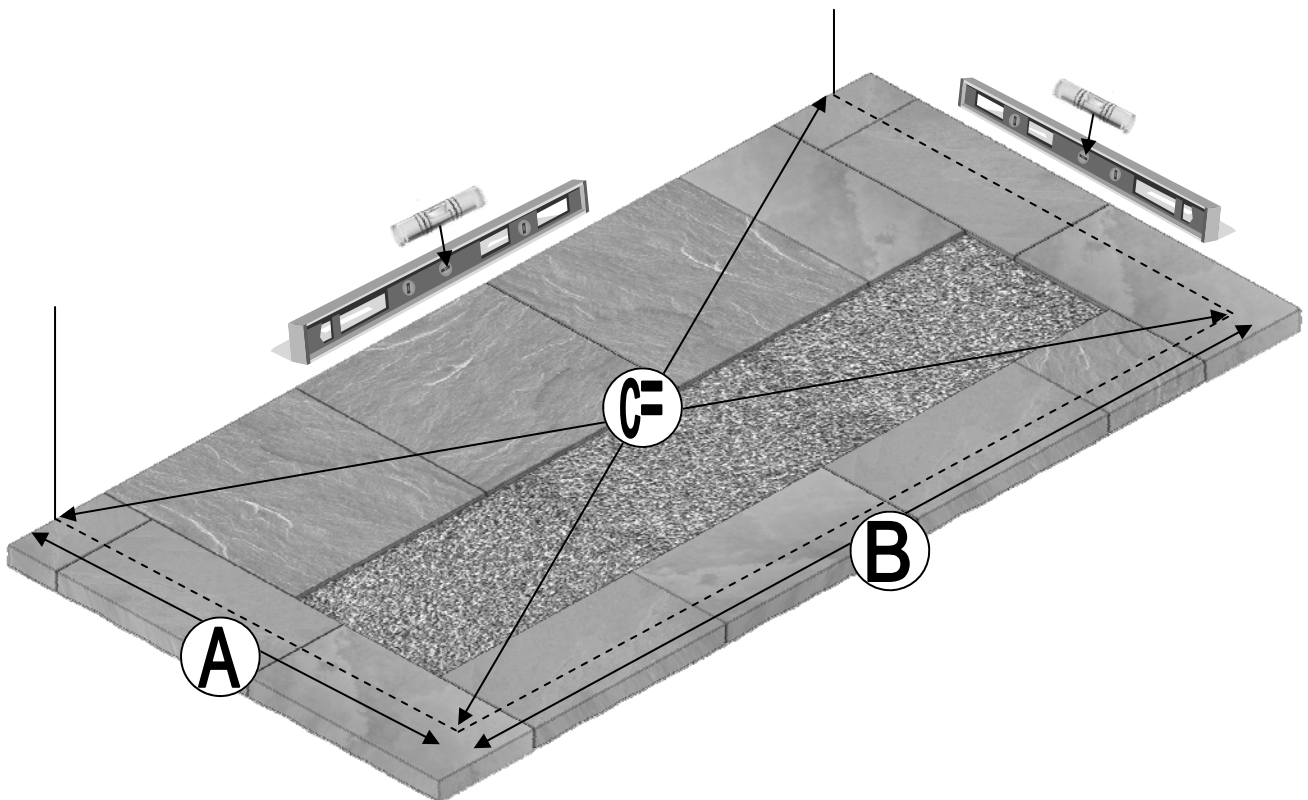

EXTERNAL DIMENSIONS (mm)				
Model sizes listed are nominal , use ' <u>mm</u> ' measurements. i.e.: an 4 x 10 is the model 4'4" x 10' 8"				
MODEL		A (mm) WIDTH	B (mm) LENGTH	C (mm) DIAGONAL
4' LEAN-TO	4 x 4 Lt	1332	1392	1927
	4 x 6 Lt		2012	2413
	4 x 8 Lt		2632	2950
	4 x 10 Lt		3252	3514
	4 x 12 Lt		3872	4095
EXTENSIONS	6ft ext.	-	1860	-



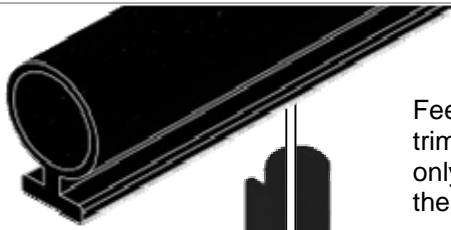

Feed glazing rubber into each glazing bar and trim to length. Notice that some channels are only used on a partition. Applying a lubricant to the aluminium channels will speed up insertion.

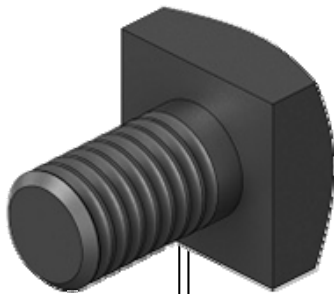
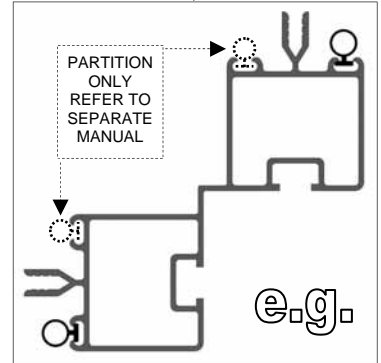
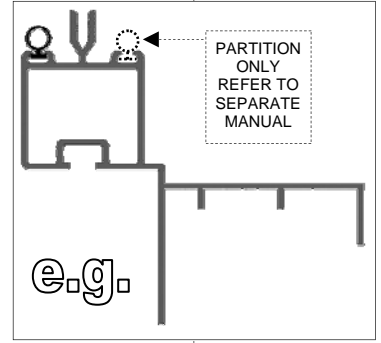
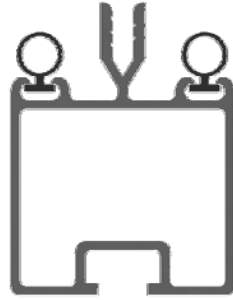

The frame is assembled by feeding square headed bolts, either 10mm or 15mm in length into the slots on glazing bars and then locating those bolts through holes in purlings and cills, etc... Twist in (rectangular) crop headed bolts are also used towards the end of construction to attach components to the frame when the glazing bar slots are no longer exposed at the ends.

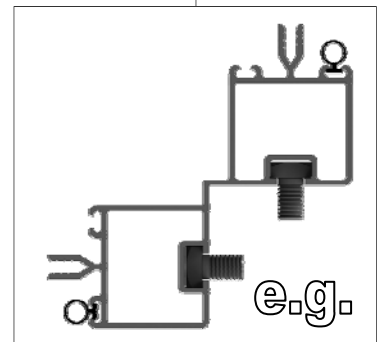
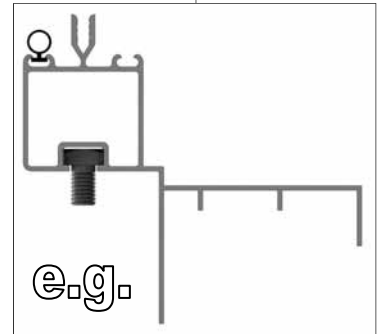
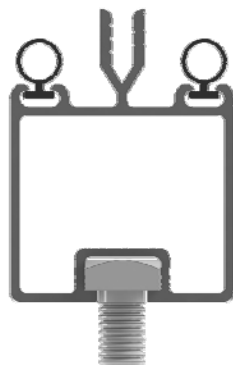
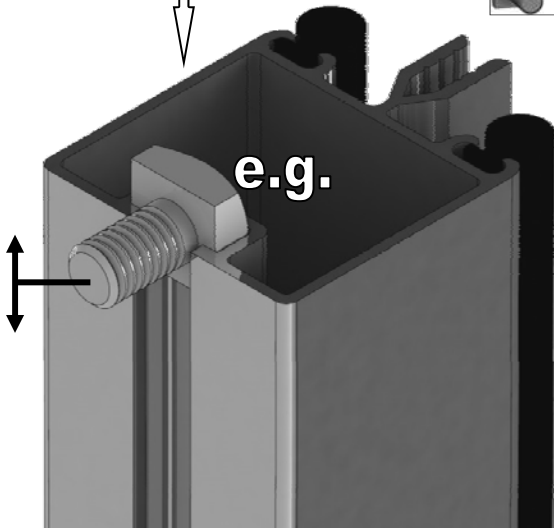

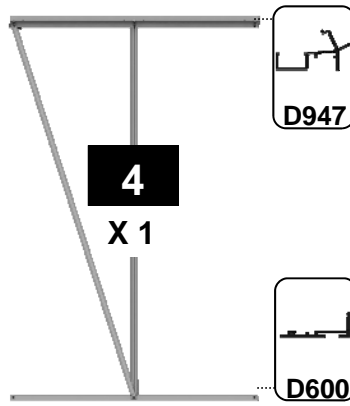
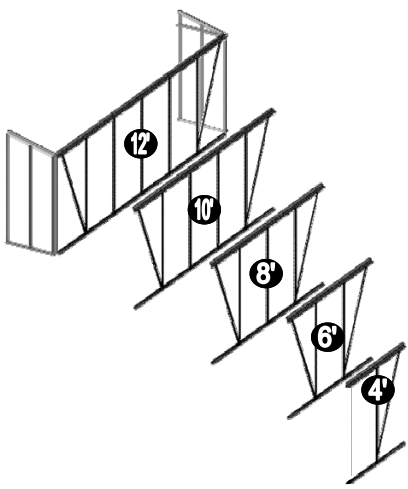

4LT HIGH SIDE 4 X 1		
Part No	mm	Quantity
D947	1277	1
D600	1270	1
D508	1930	1
D524	2026	1
D174		1
M6-10mm		1
M6-15mm		2
M6-NUT		3
Rubber	1000	4

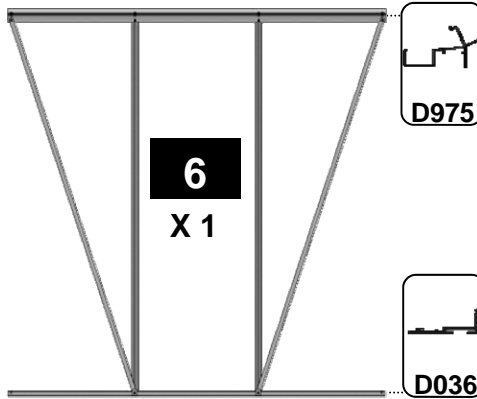

4LT HIGH SIDE 6 X 1		
Part No	mm	Quantity
D975	1897	1
D036	1890	1
D508	1930	2
D524	2026	2
D174		2
M6-10mm		2
M6-15mm		4
M6-NUT		6
Rubber	1000	8

e.g. ①

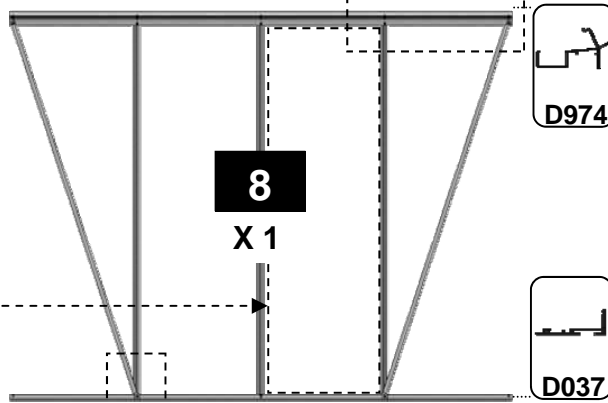

4LT HIGH SIDE 8 X 1		
Part No	mm	Quantity
D974	2517	1
D037	2510	1
D508	1930	3
D524	2026	2
D174		2
M6-10mm		3
M6-15mm		5
M6-NUT		8
Rubber	1000	12

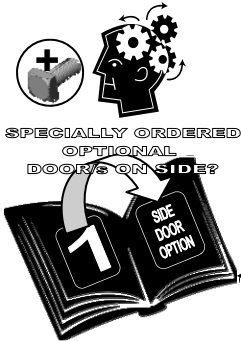

e.g.

e.g. ②

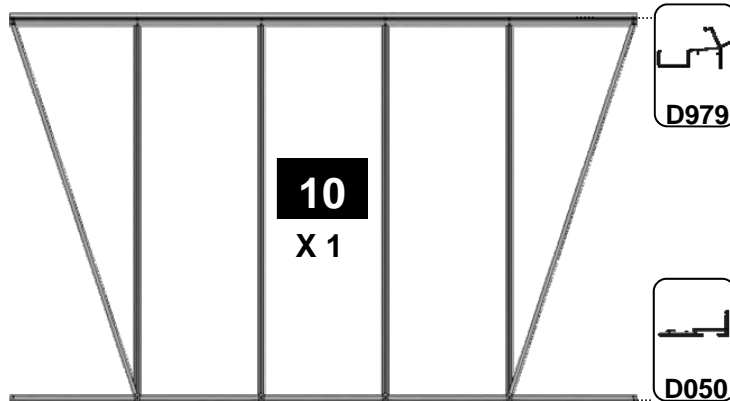

4LT HIGH SIDE 10X 1		
Part No	mm	Quantity
D979	3137	1
D050	3130	1
D508	1930	4
D524	2026	2
D174		4
M6-10mm		4
M6-15mm		6
M6-NUT		10
Rubber	1000	16

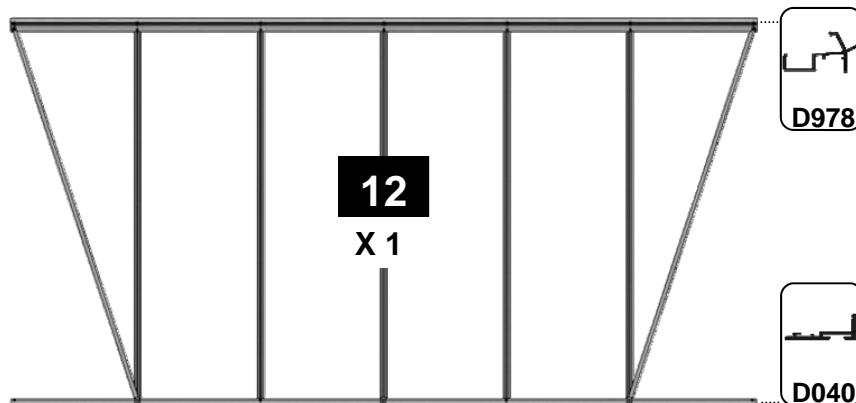

4LT HIGH SIDE 12X 1		
Part No	mm	Quantity
D978	3757	1
D040	3750	1
D508	1930	5
D524	2026	2
D174		4
M6-10mm		5
M6-15mm		7
M6-NUT		12
Rubber	1000	20



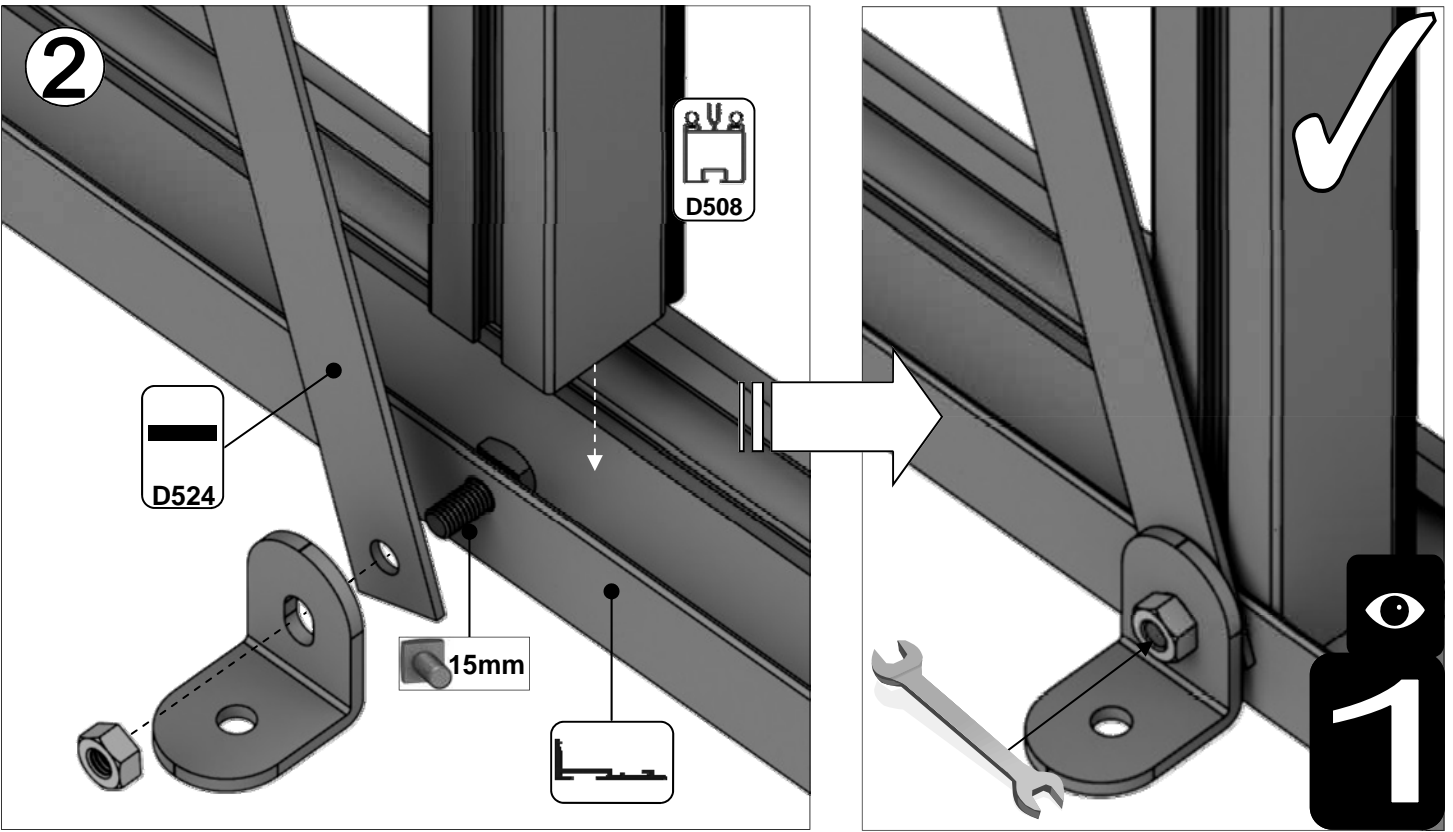
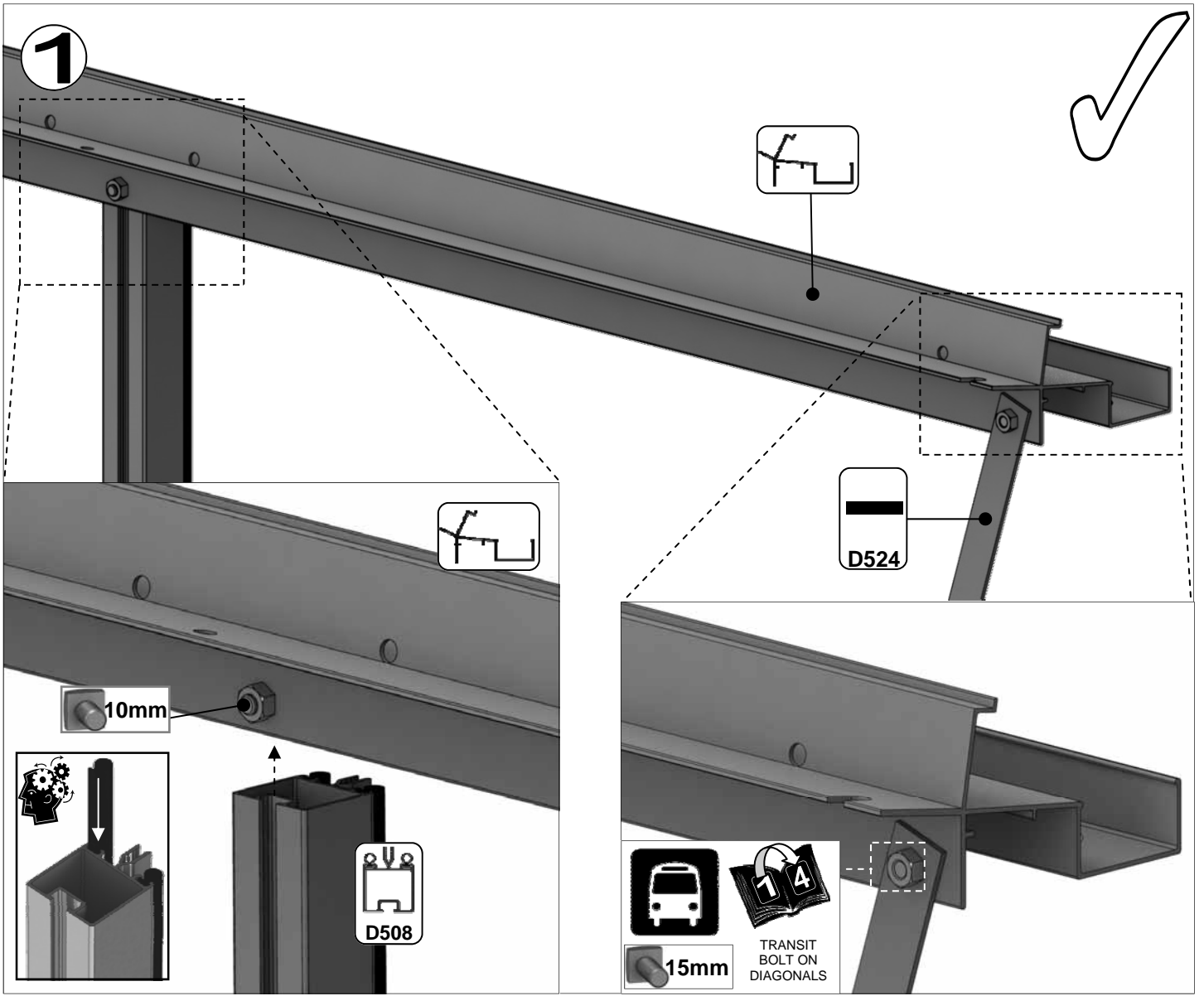

Part No	mm	Quantity
D510	1930	1
D600	1270	1
D940	1286	1
D955	2037	1
D956	2147	1

**DOOR ON LEFT
EXTERNAL VIEW**

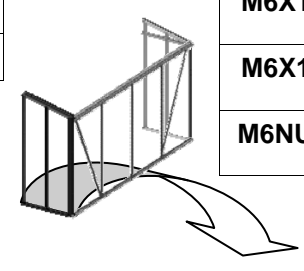

Part No	mm	Quantity
D174		3
D227		14m
M6X10		6
M6X15		8
M6NUT		14

**DOOR ON RIGHT
EXTERNAL VIEW**

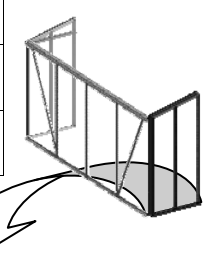

Part No	mm	Quantity
D510	1930	1
D600	1270	1
D940	1286	1
D955	2037	1
D956	2147	1

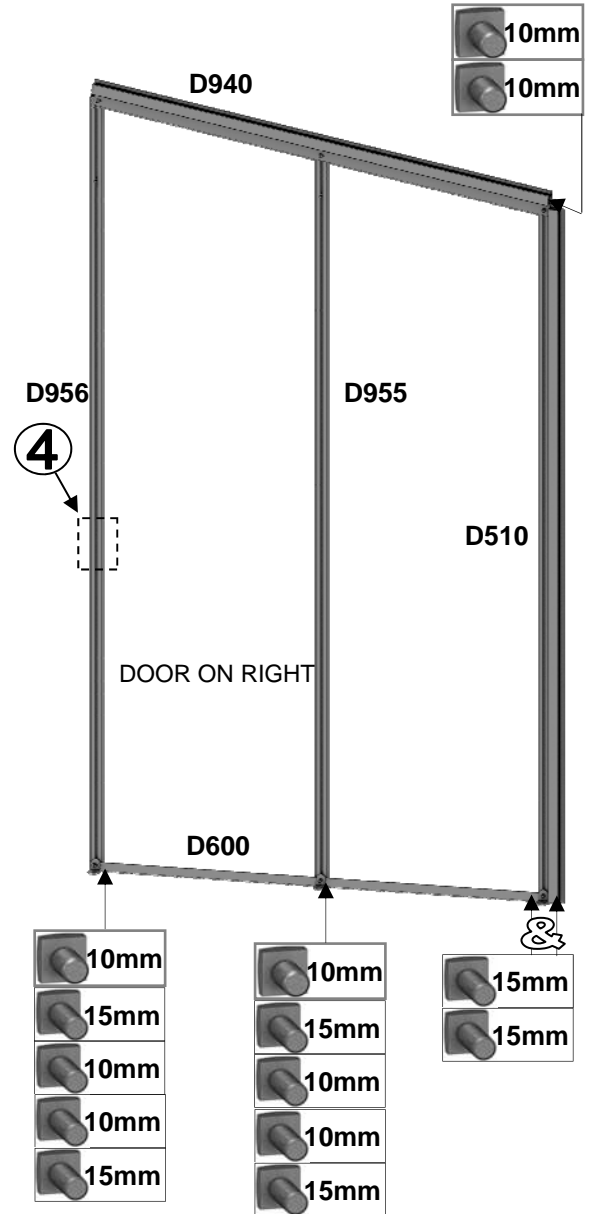
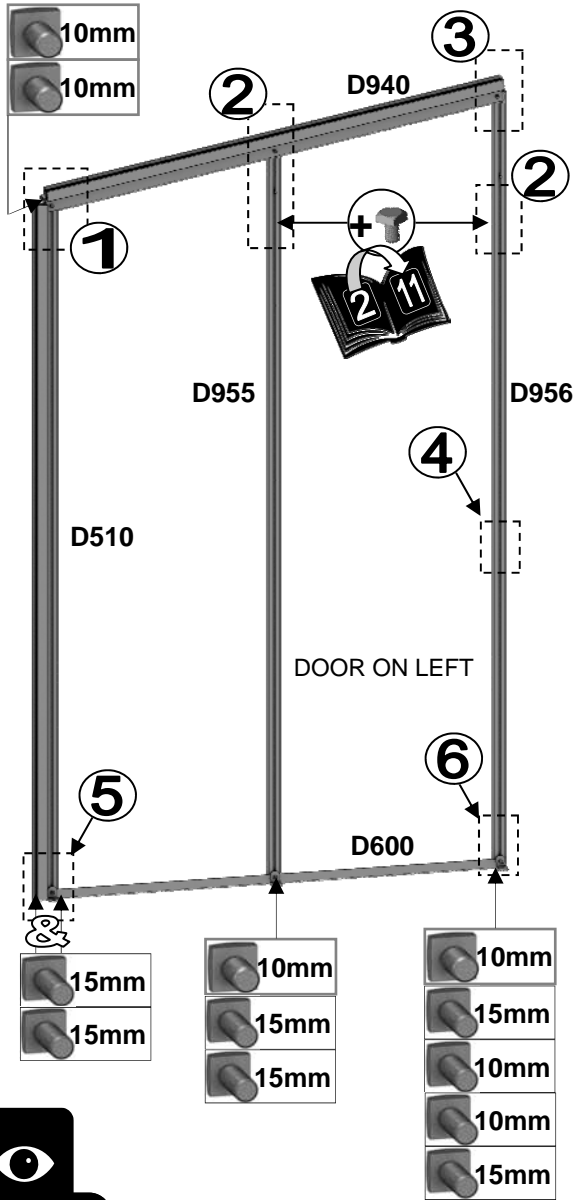

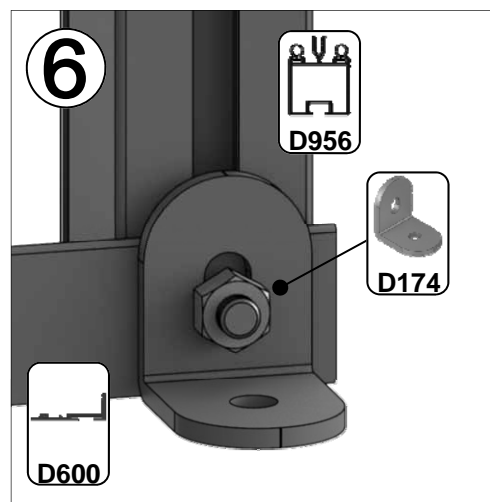
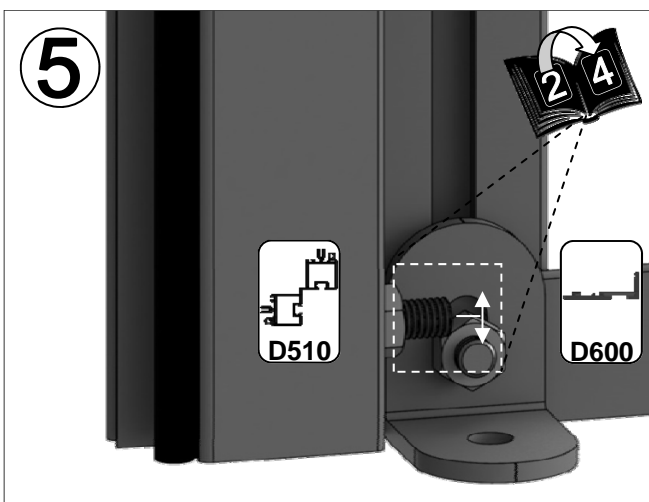
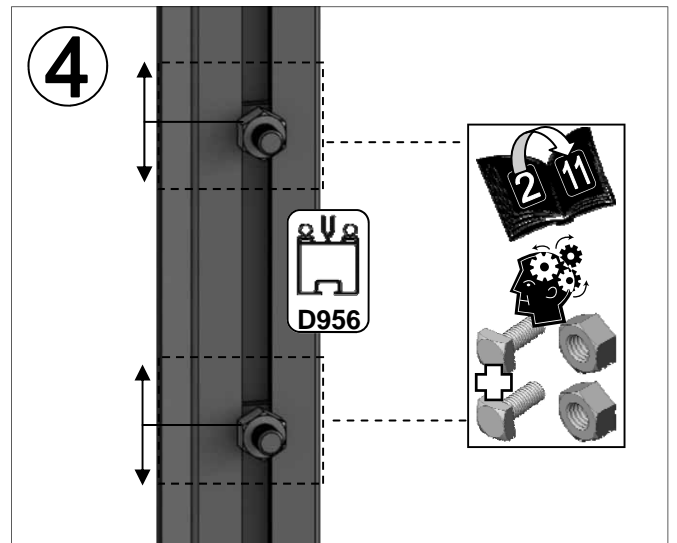
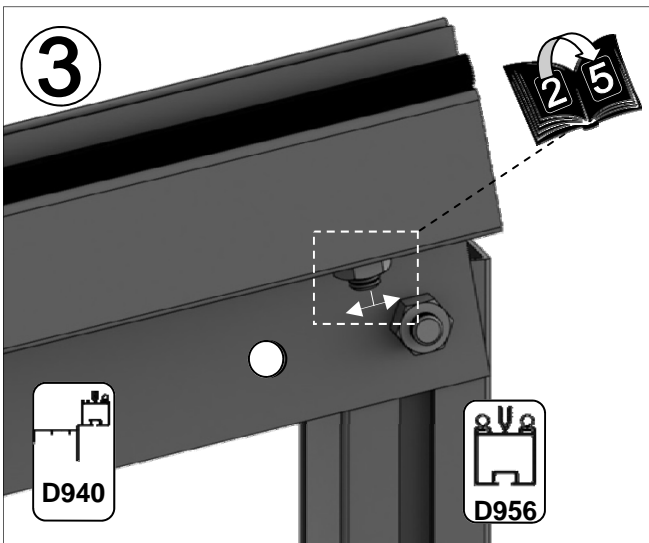
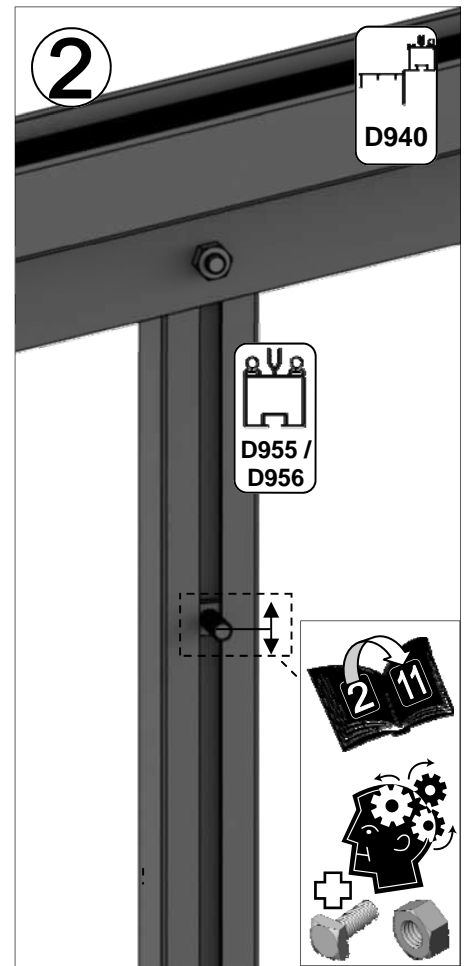
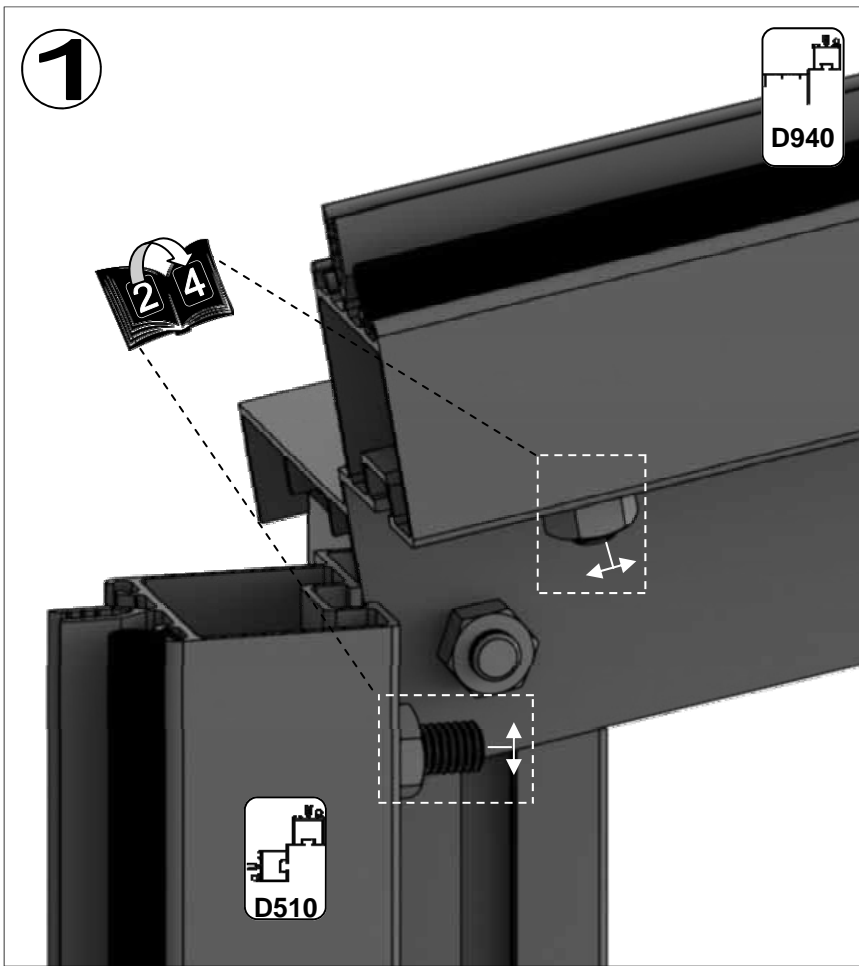

Part No	mm	Quantity
D510	1930	1
D600	1270	1
D653	1270	1
D940	1286	1
D955	2037	1
D956	2147	1

DOOR ON LEFT EXTERNAL VIEW

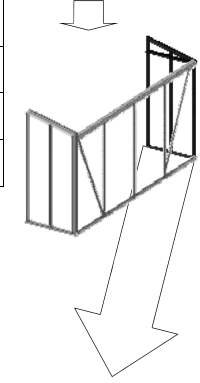

Part No	mm	Quantity
D174		3
D227		14m
M6X10		4
M6X15		8
M6NUT		12

DOOR ON RIGHT EXTERNAL VIEW

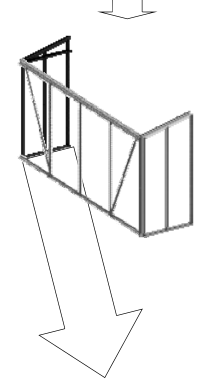

Part No	mm	Quantity
D510	1930	1
D600	1270	1
D653	1270	1
D940	1286	1
D955	2037	1
D956	2147	1

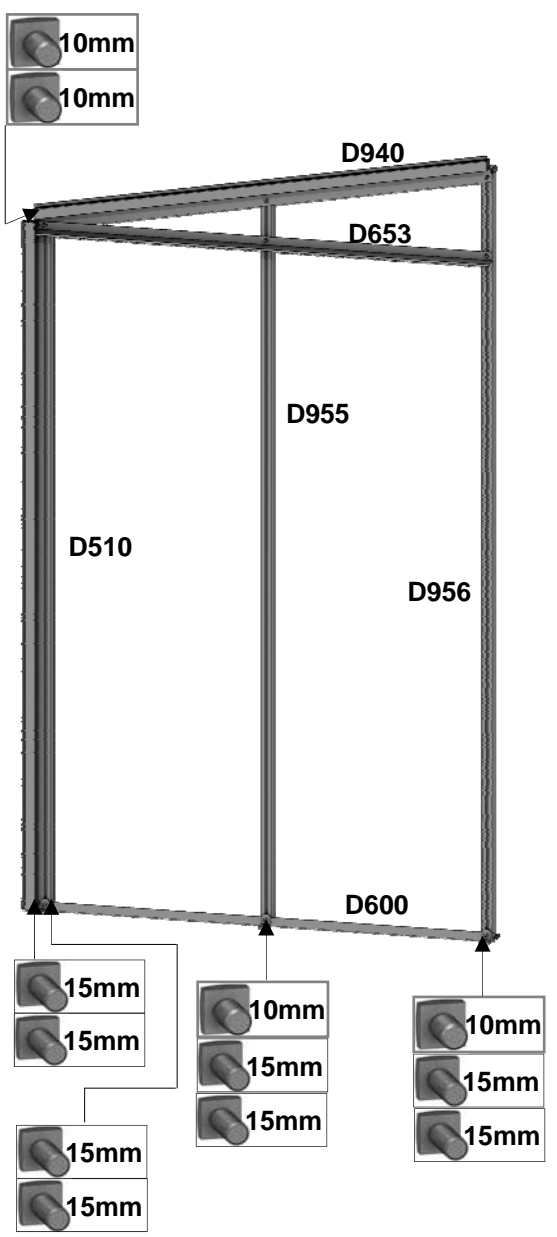
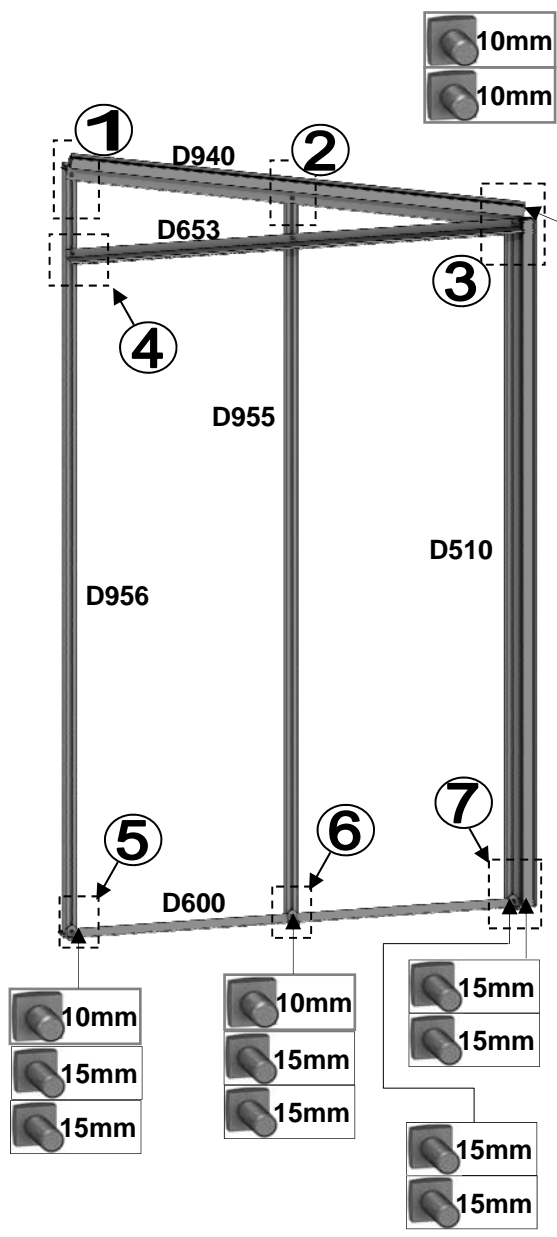

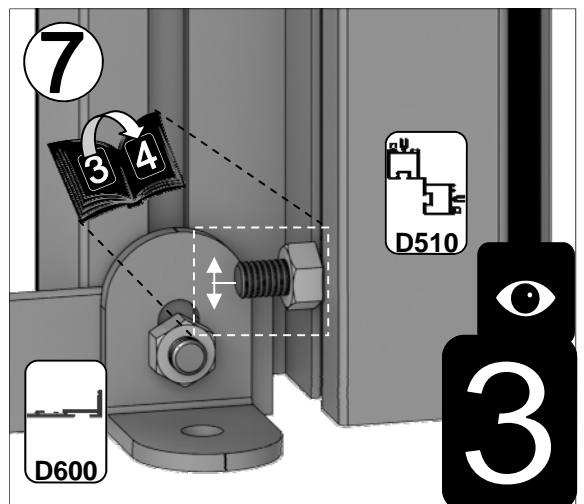
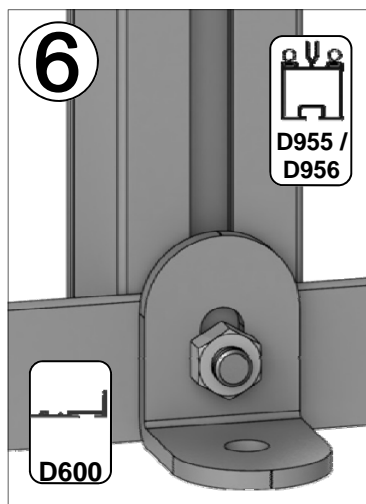
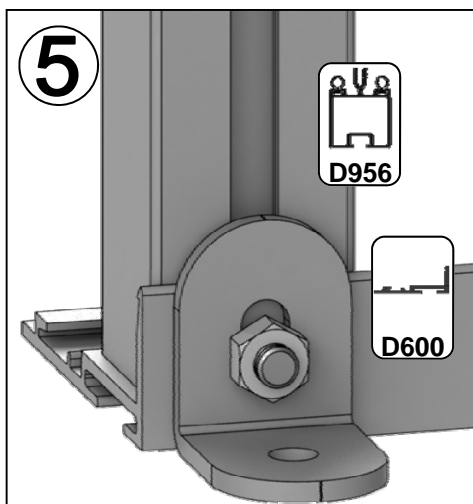
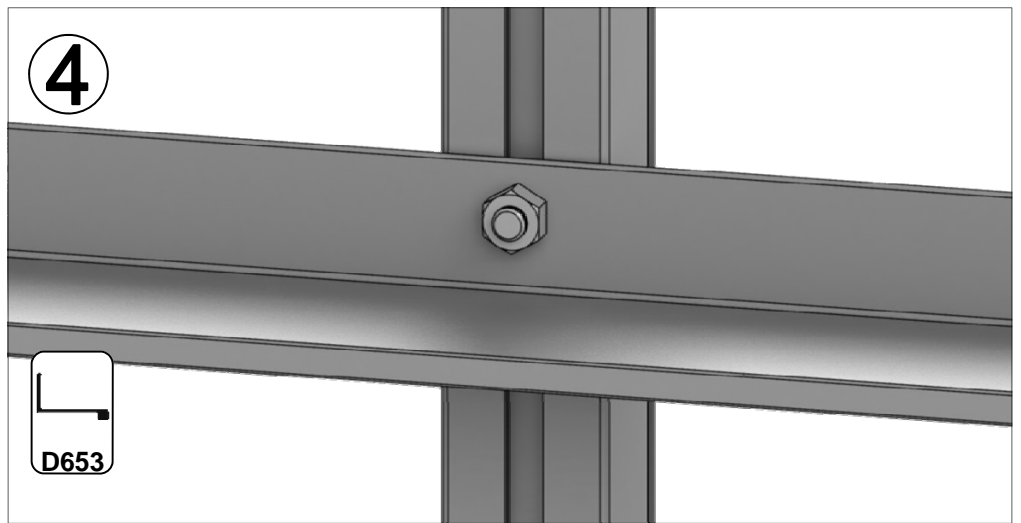
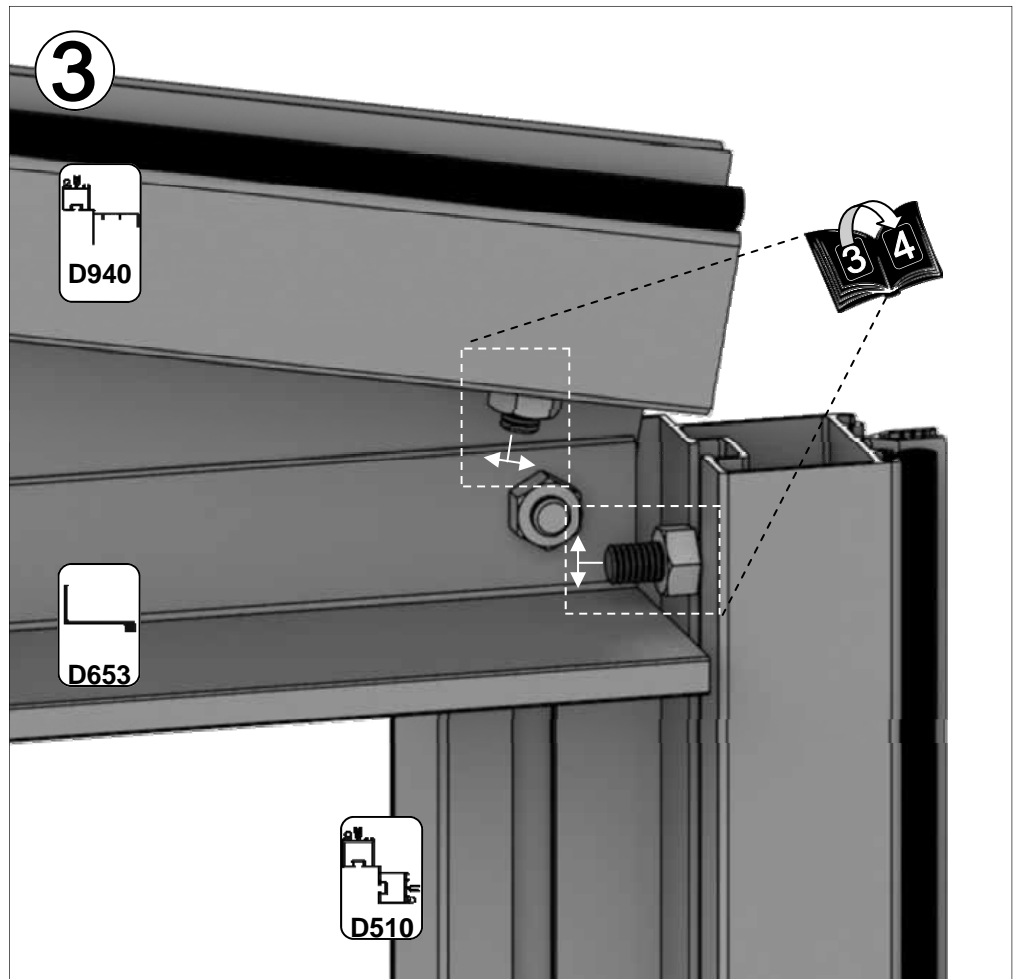
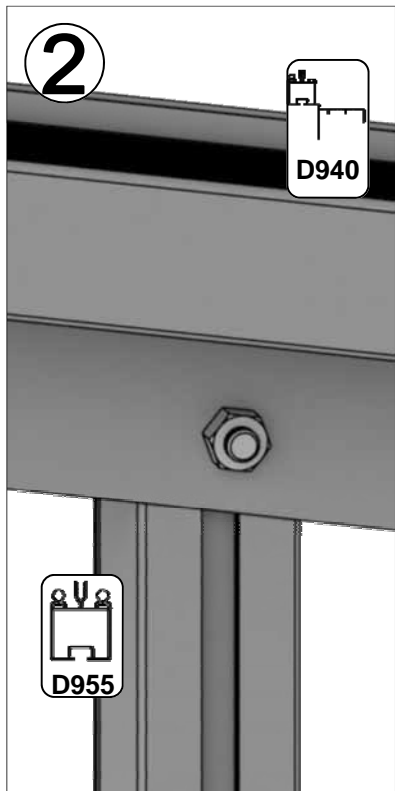
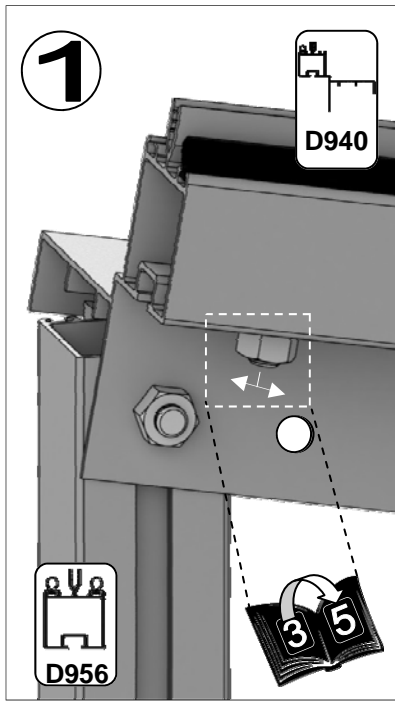

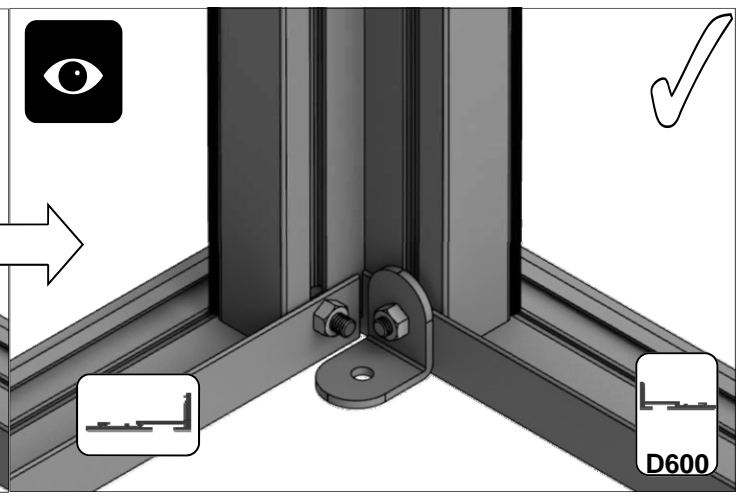
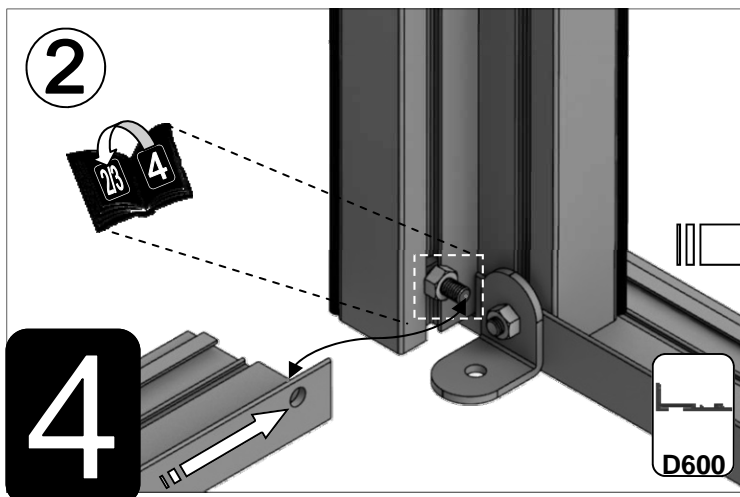
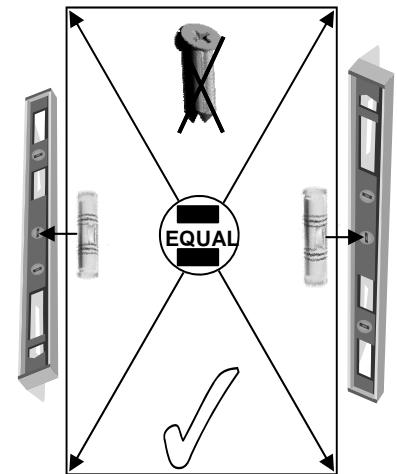
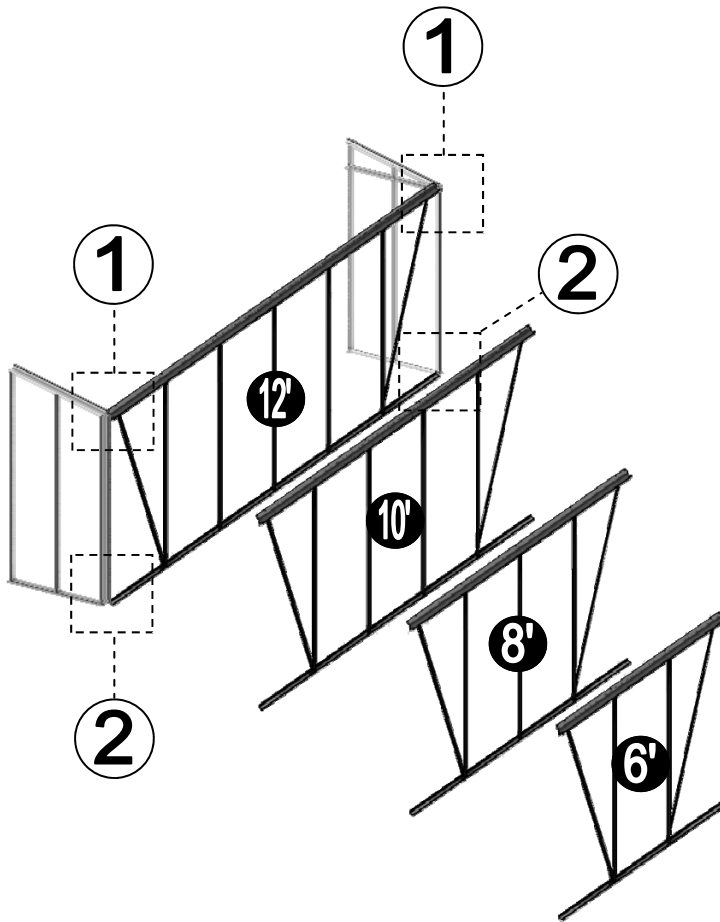
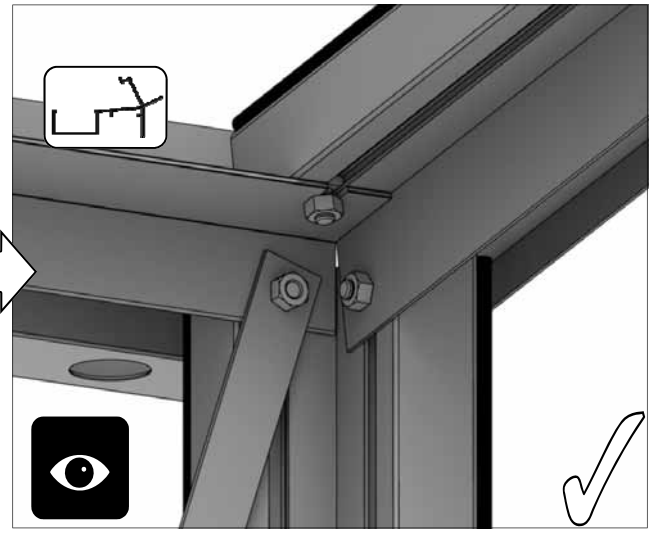
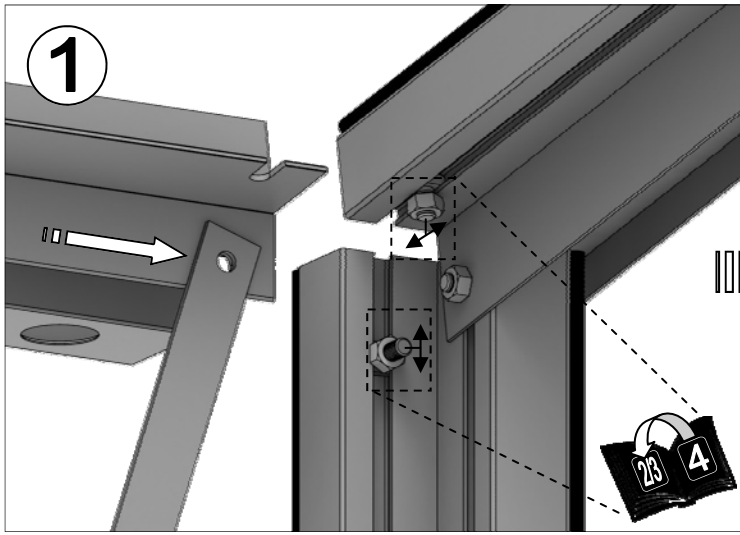

4'			6'			8'			10'			12'		
Part	mm	Quantity	Part	mm	Quantity	Part	mm	Quantity	Part	mm	Quantity	Part	mm	Quantity
D948	1277	1	D976	1897	1	D973	2517	1	D981	3137	1	D977	3757	1
D942	1286	1	D942	1286	2	D942	1286	3	D942	1286	4	D942	1286	5
RUBBER	1000	3	RUBBER	1000	6	RUBBER	1000	8	RUBBER	1000	11	RUBBER	1000	13

1

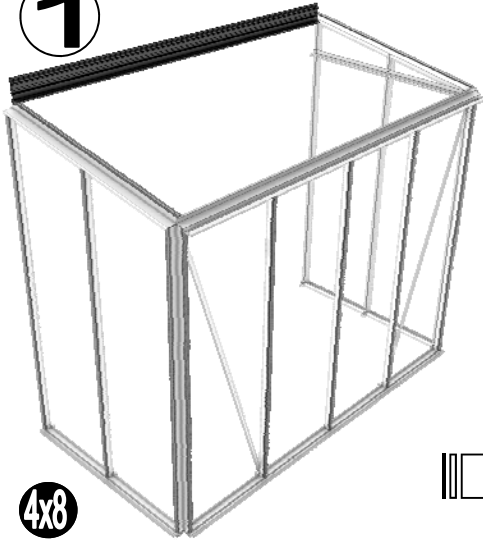

4x8

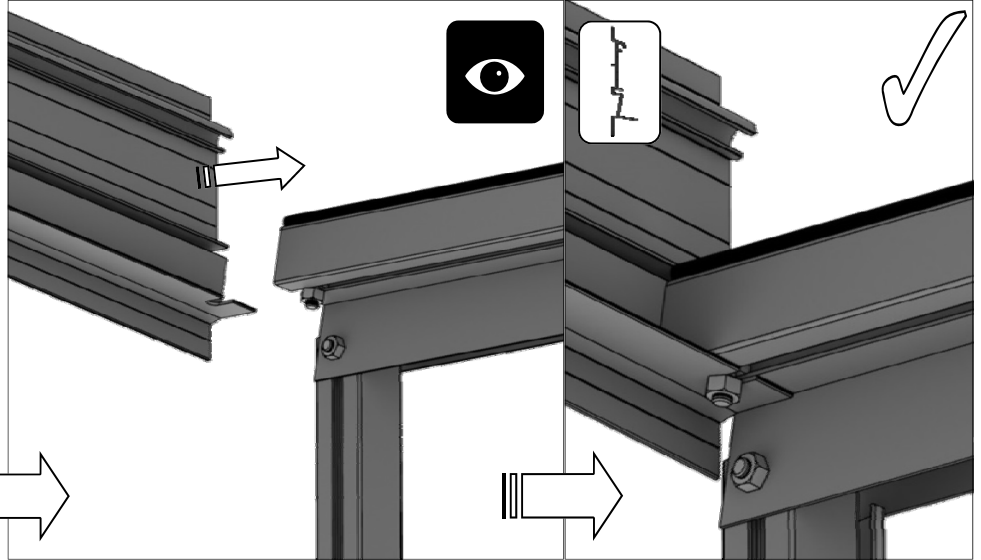

2

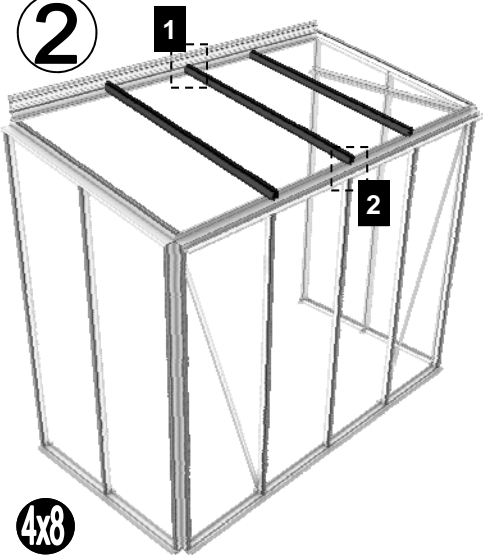

4x8

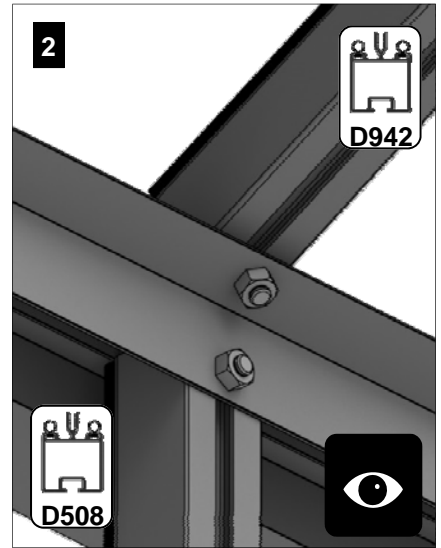
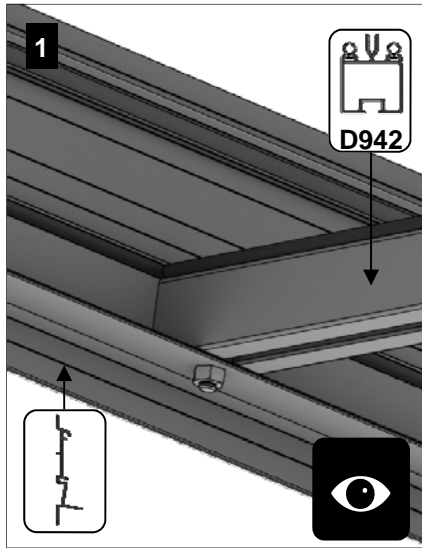

3

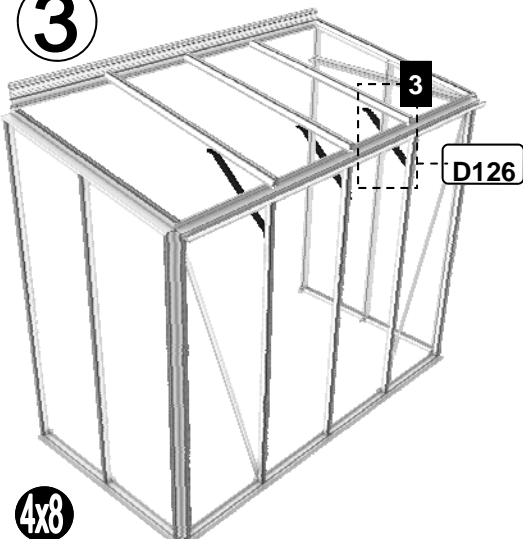

4x8

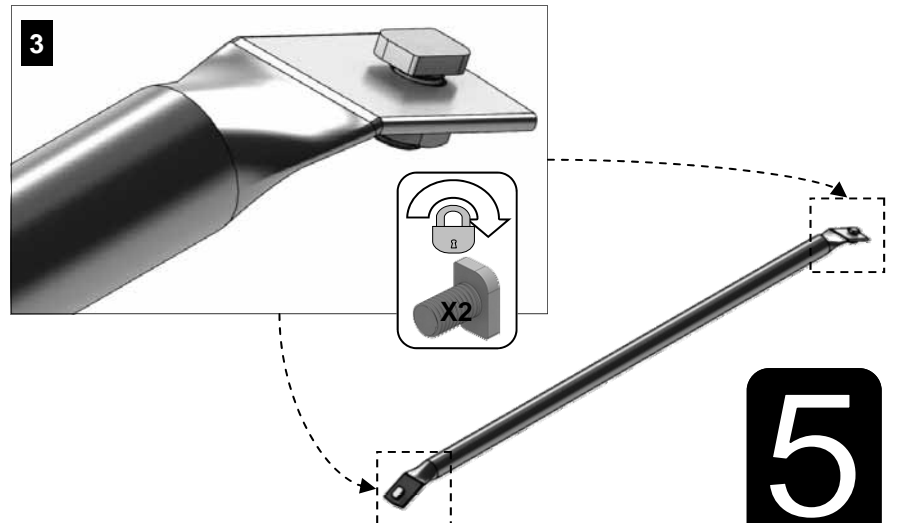

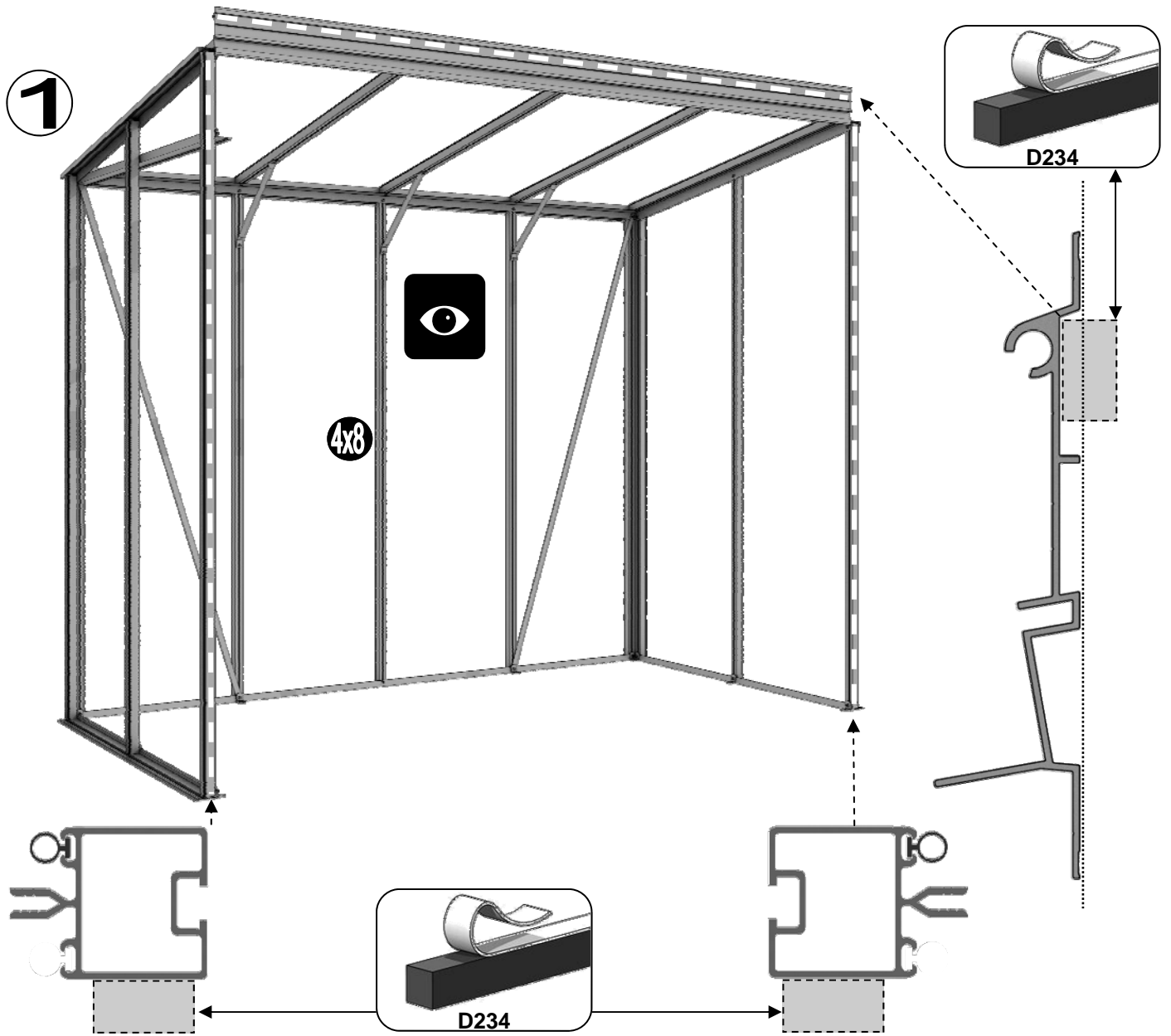

1

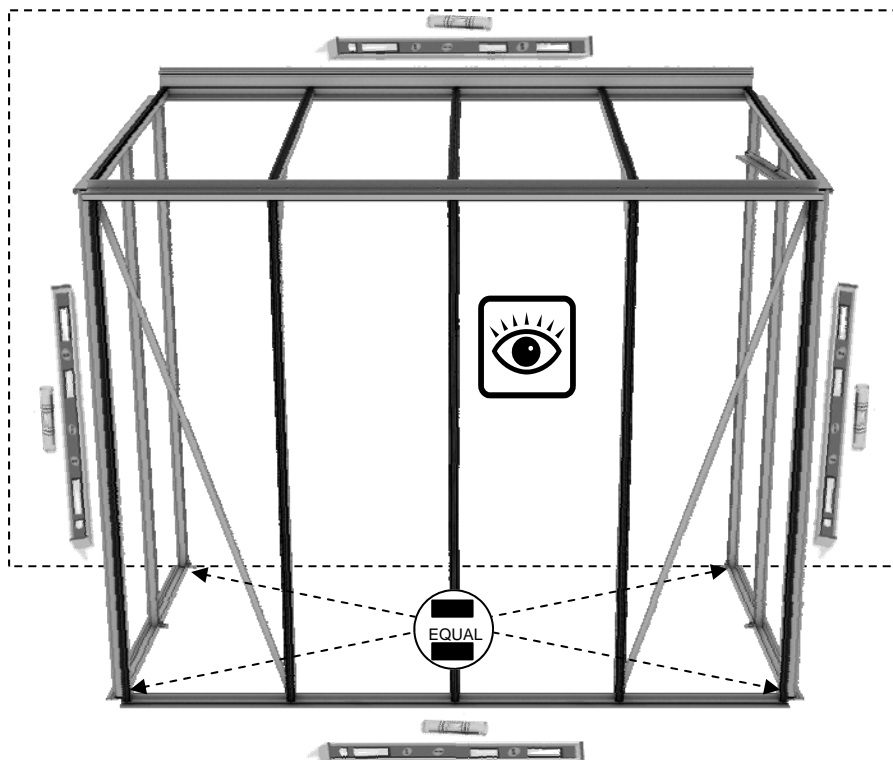

2



6

		4x4 4x6 4x8 4x10 4x12					
Part No		mm	Quantity				
SYSCR3		75	9	11	12	13	14
SYRAWL		50	9	11	12 <td 13	14	



3

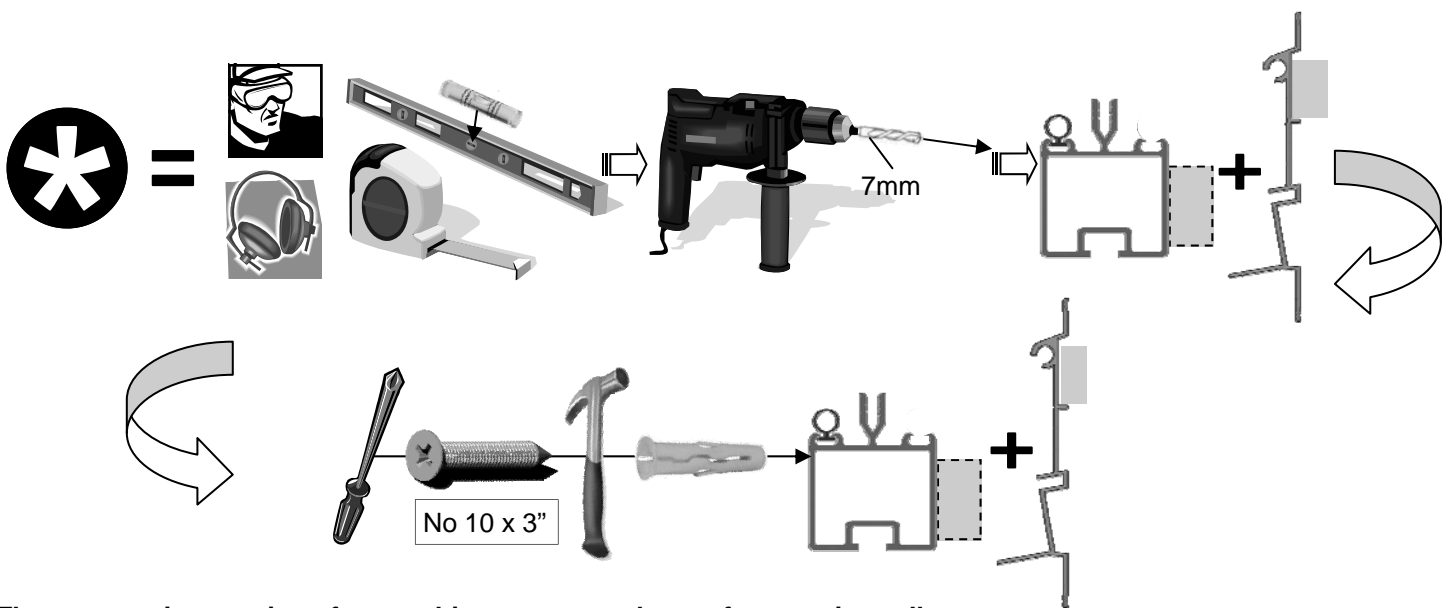
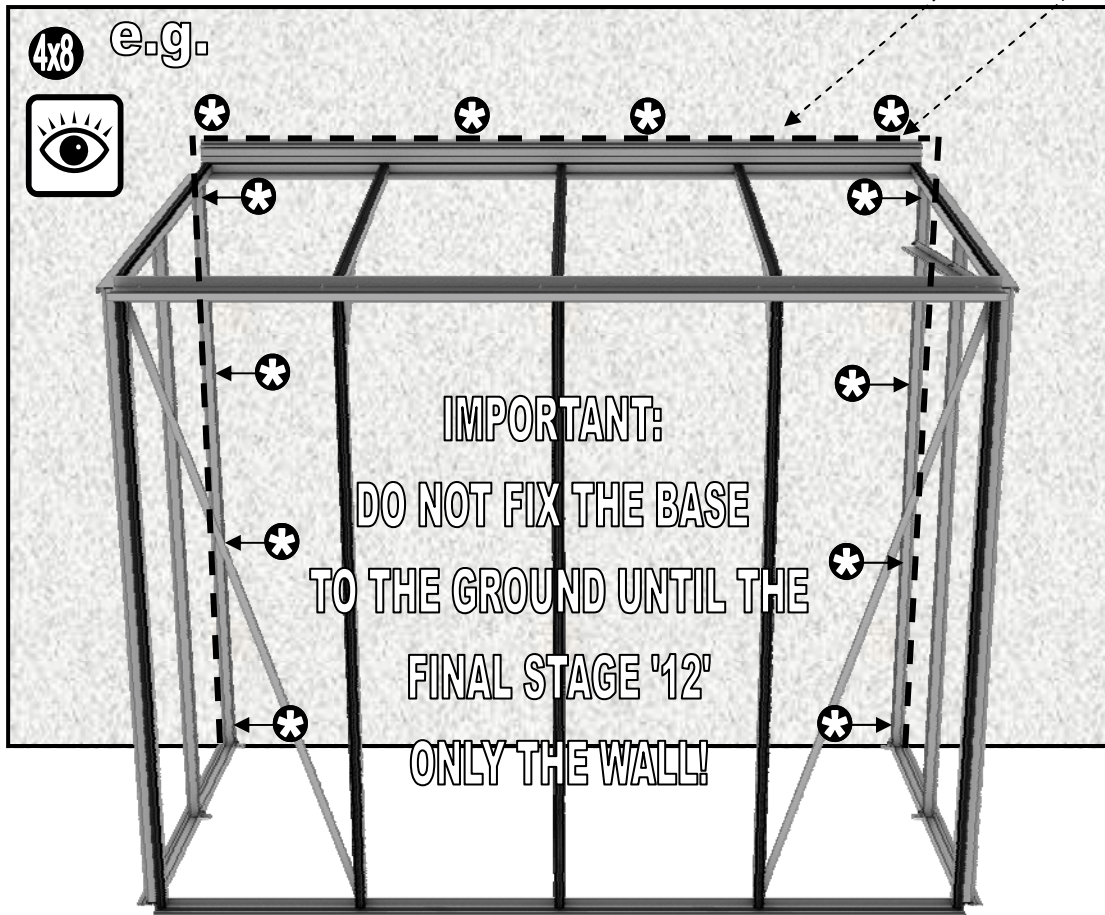

There are various options for attaching your greenhouse frame to its wall.

- 1) Drill through the vertical wall bars with a 7mm drill/hammer drill using a 7mm masonry bit, Use 3" screws to secure the wall bars.
- 2) Drill through the vertical wall bars with a 7mm drill bit and enlarge the inner hole to 10mm. Use 2" screws to secure the wall bars hiding the screw heads inside the bars to give a neat finish.
- 3) Use L-shaped brackets and 2" screws to secure the frame to the wall similar to anchoring the greenhouse down (e.g. section 12).

6

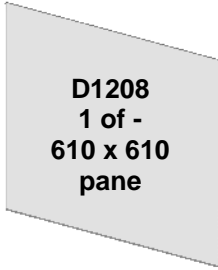

Part No		mm	Quantity
D866		639	1
D863L		613	1
D863R		613	1
D862		593	1

Part No		mm	Quantity
D220 PLUS FS6060 SCREW		N/A	2
D205		N/A	2
SY-BOLM6X11		10	4
SYNUTM6		M6	4
8 X 12 S/T FS6017		10	2
8 x 19 S/T FS6018		19	2

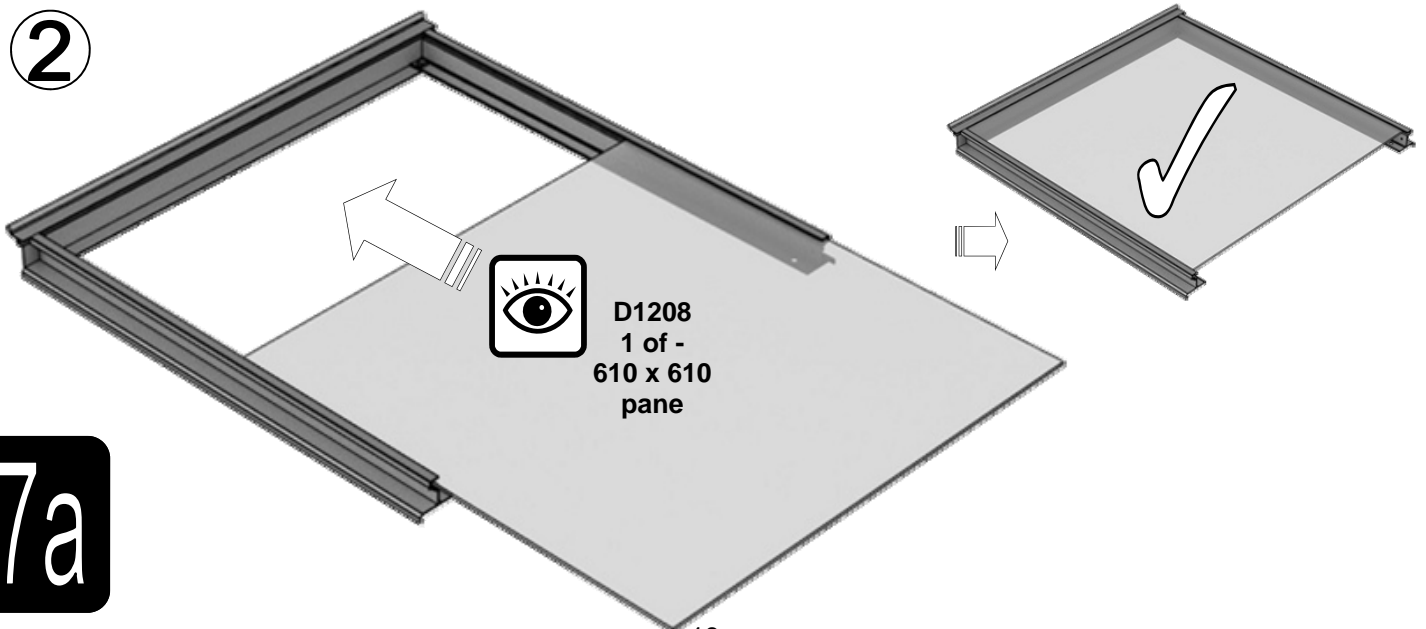
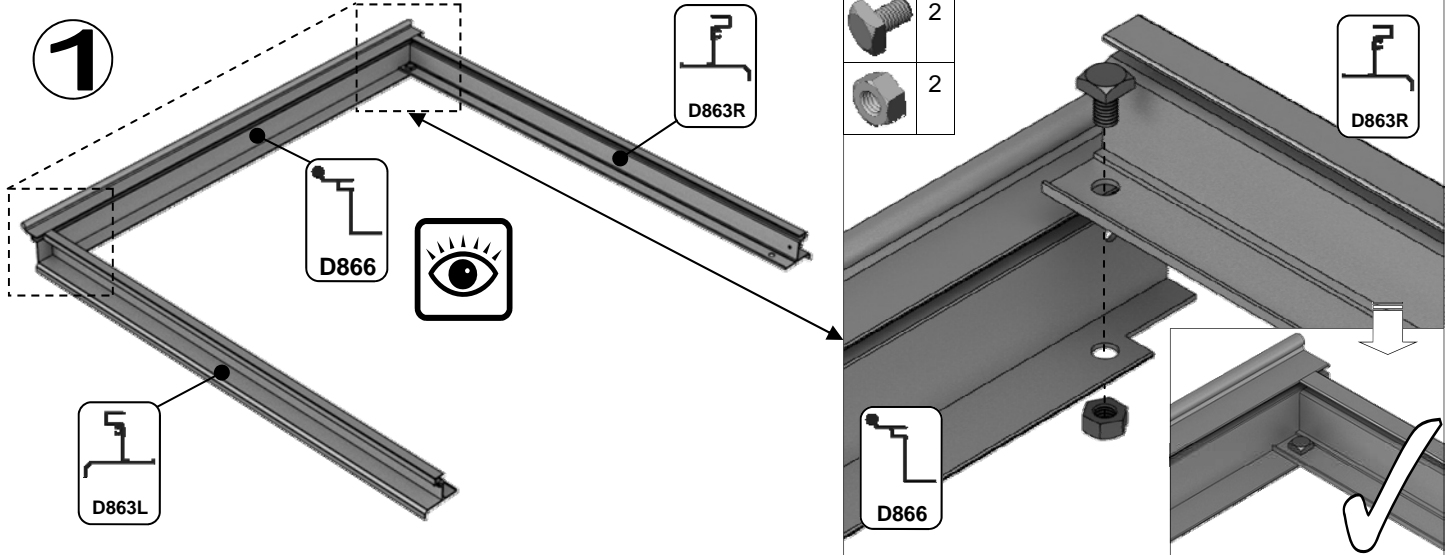

7a

3 

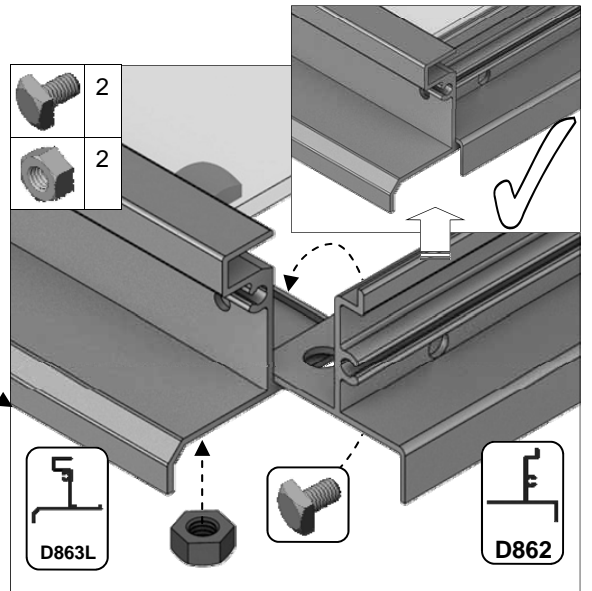
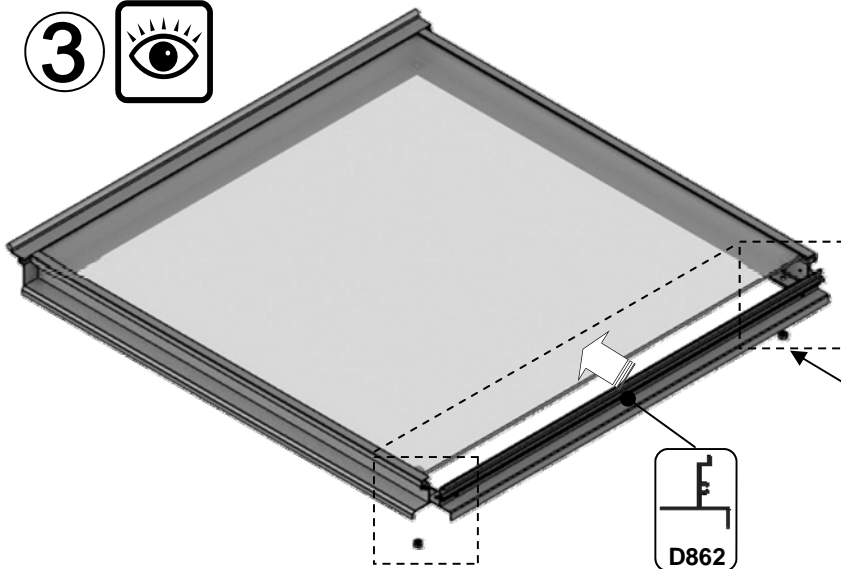

4 

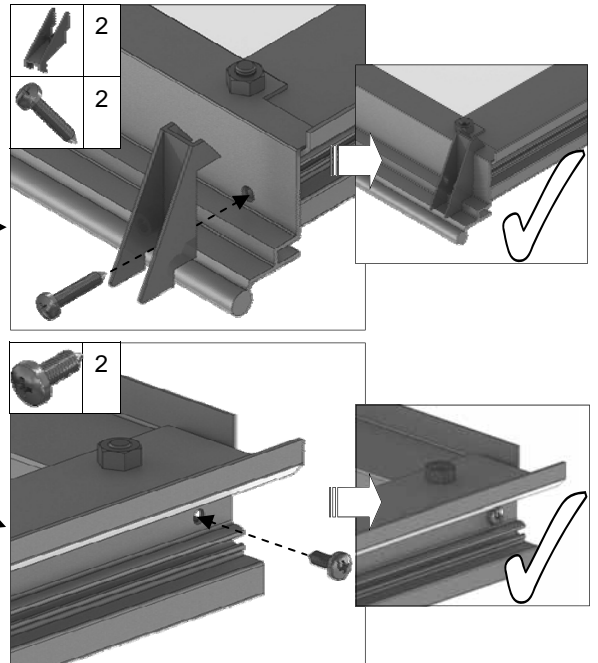
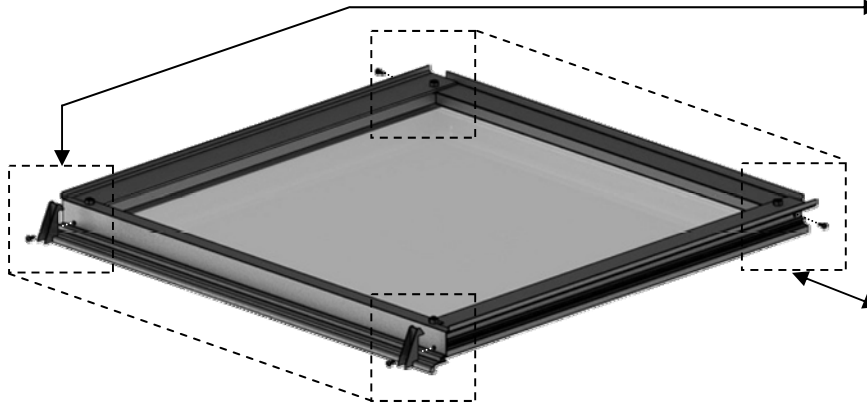
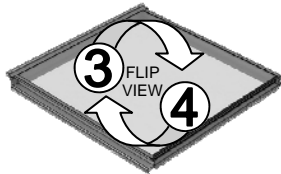



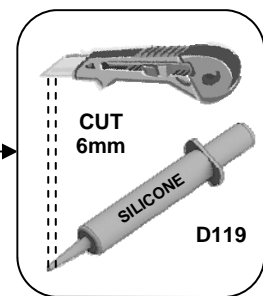
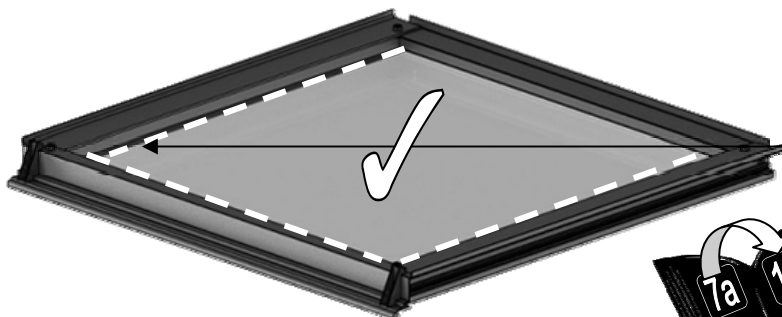



5 



7a

1 vent
slam bar = {

Part No		mm	Quantity
SY-BOLM6X11		10	2
SY-BOLM6X15		15	2
SYBOLM6 X11CROP		10	2
SYNUTM6		N/A	4

Part No		mm	Quantity
D079 PLUS FLUFF		590	1
D114		N/A	2

6

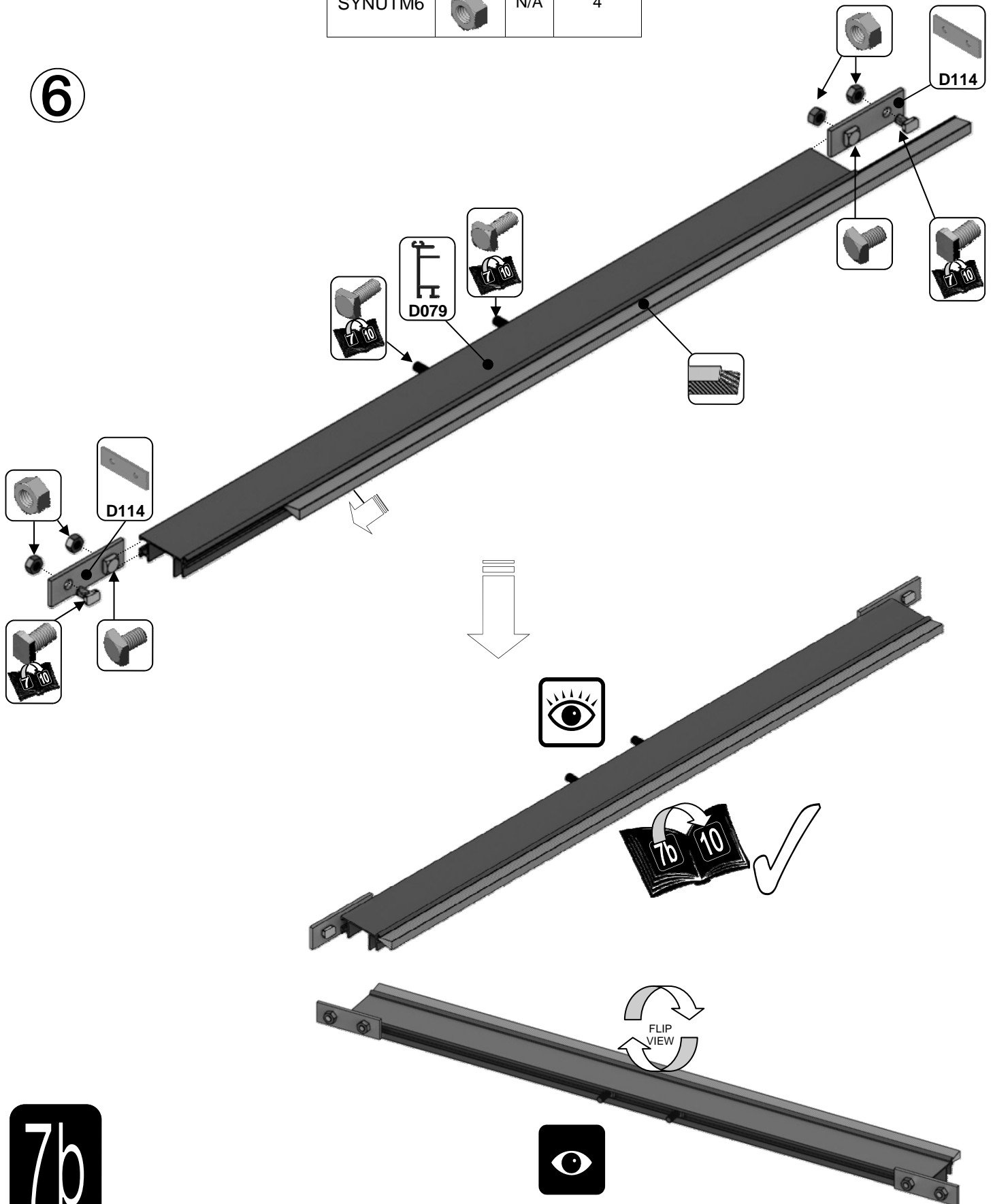

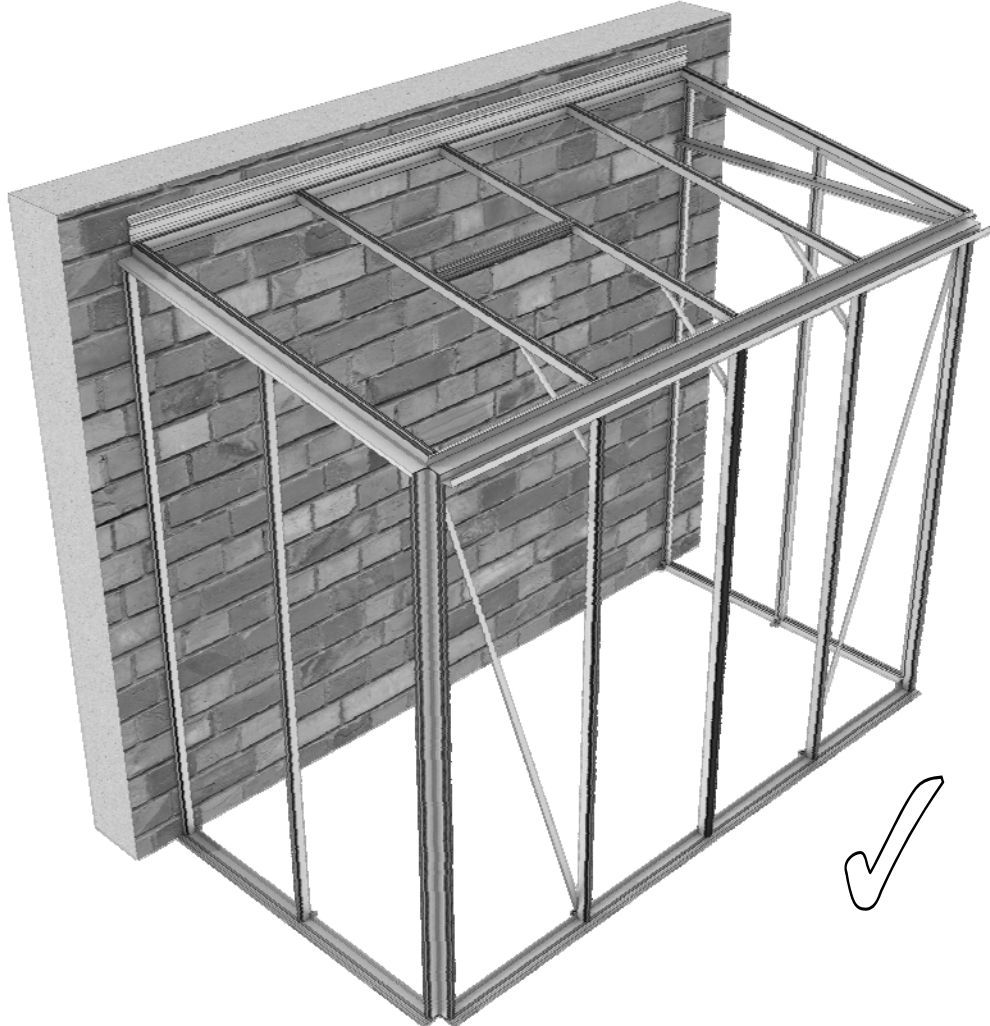
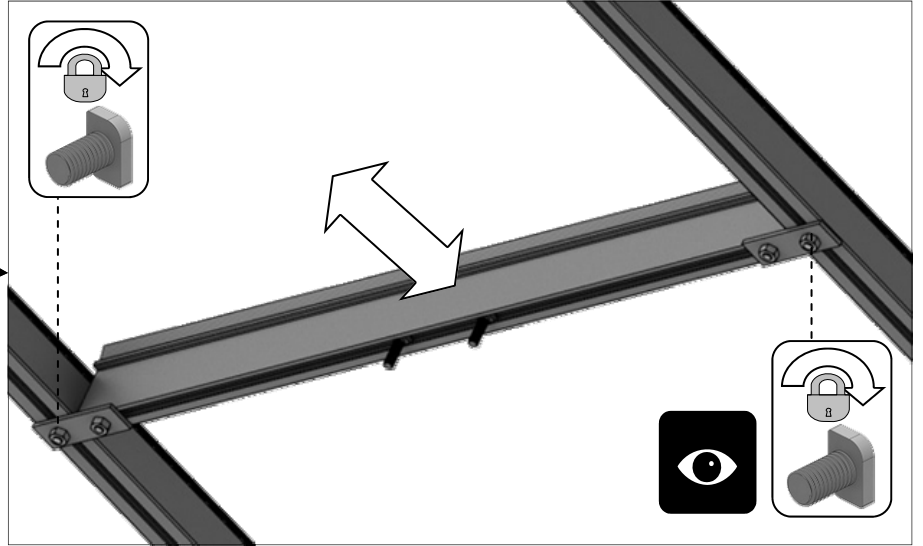
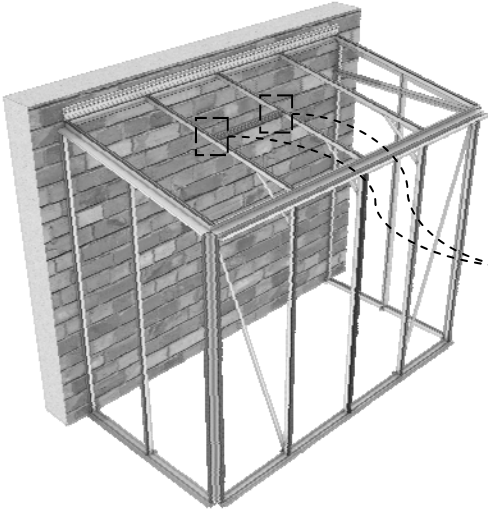
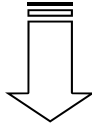
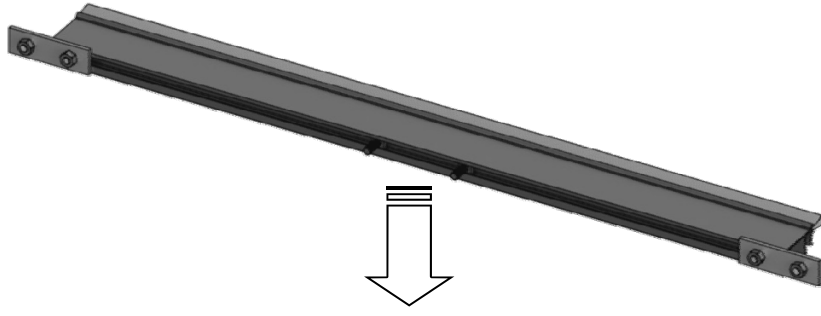

7b

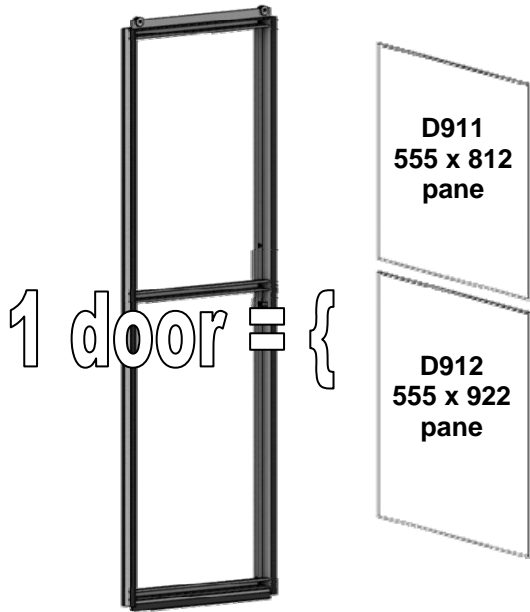





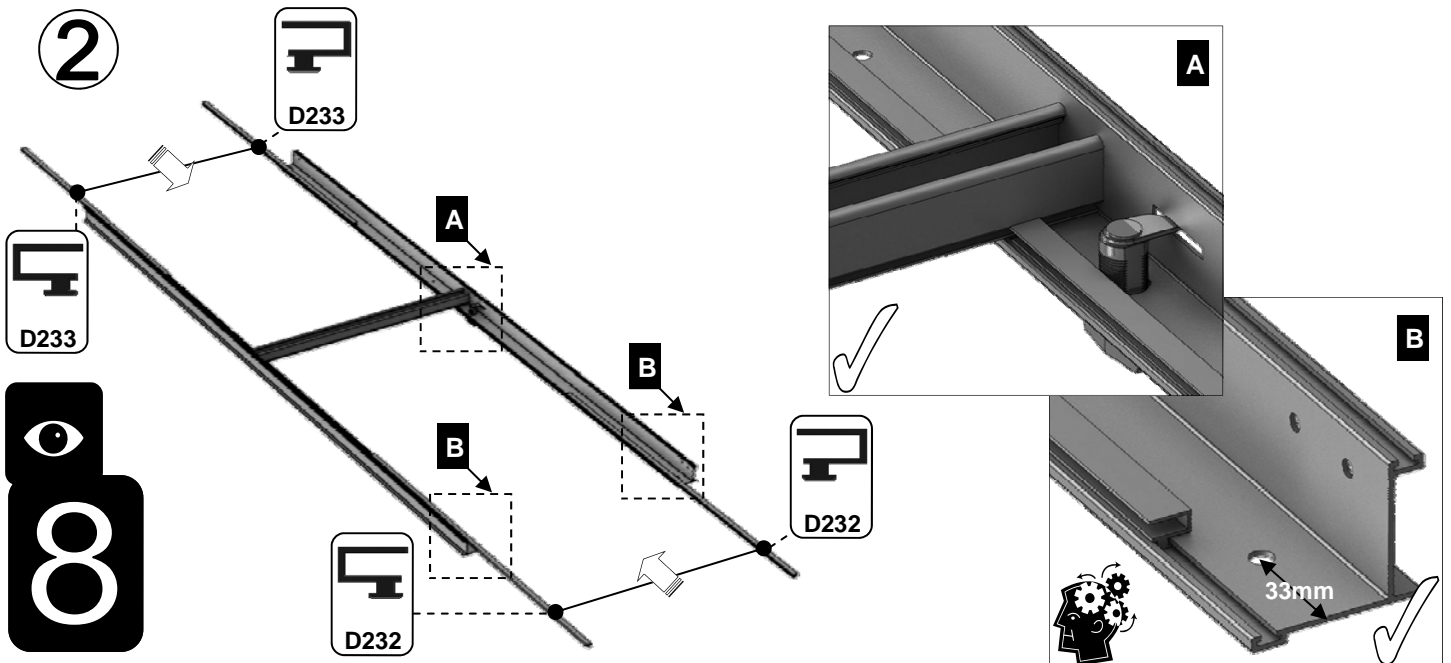
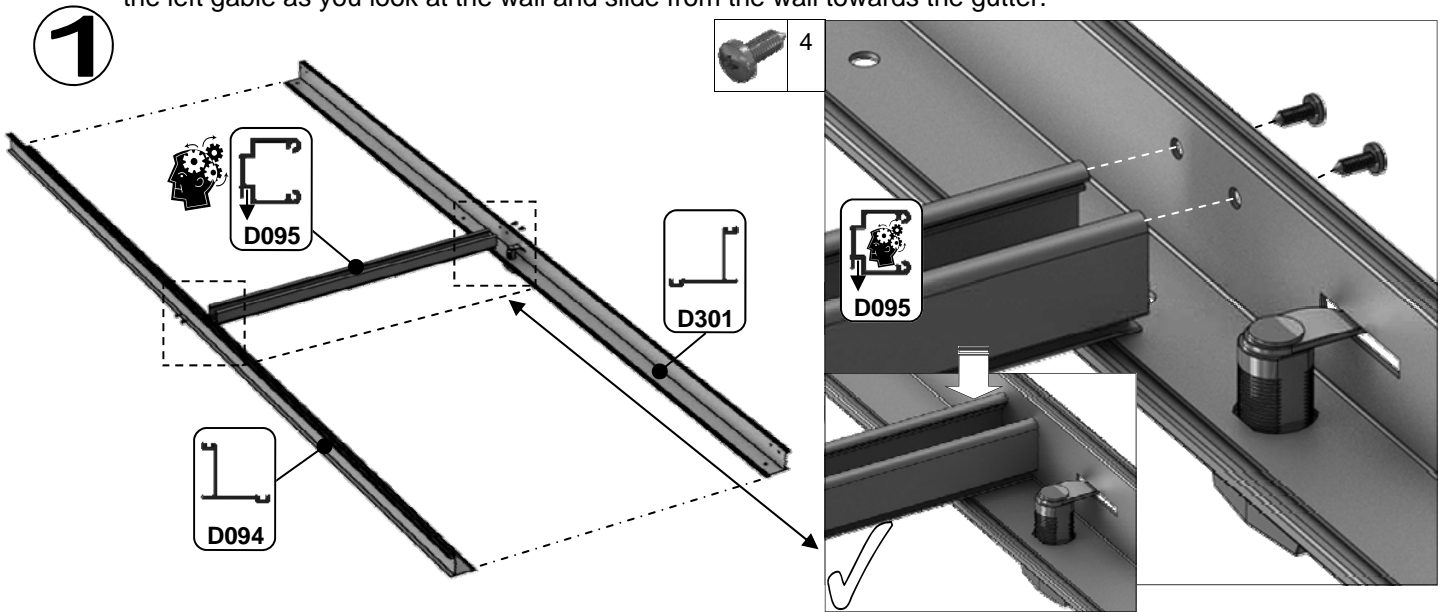

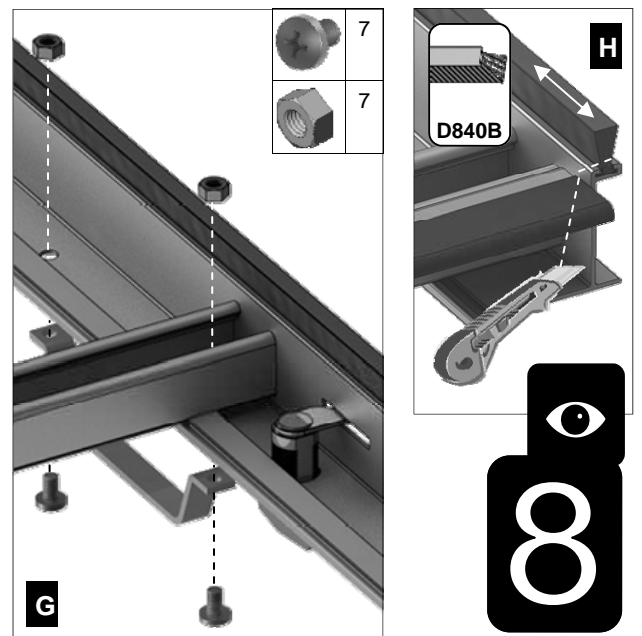
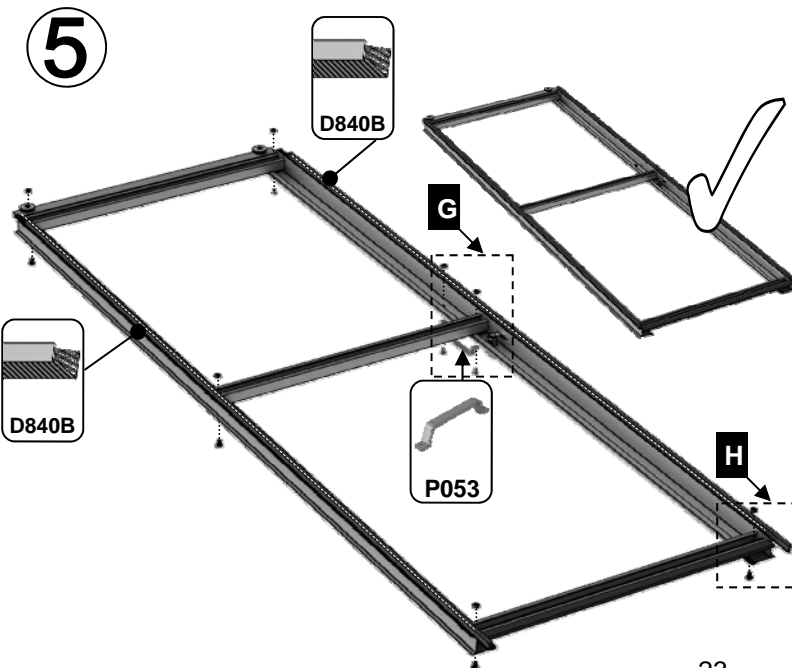
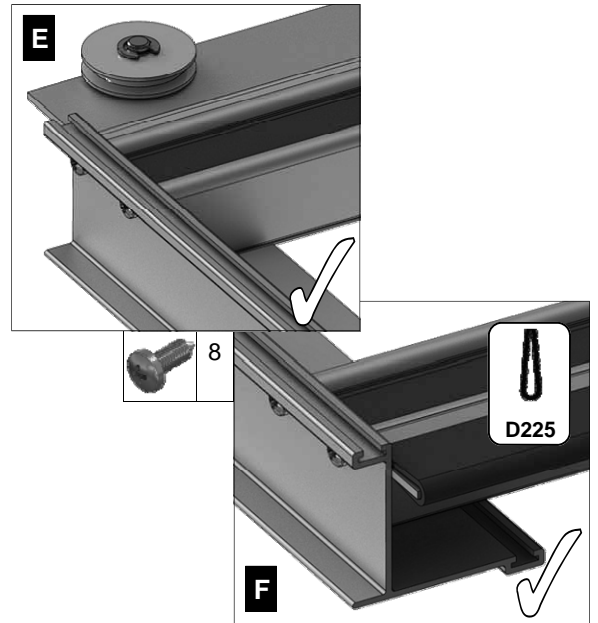
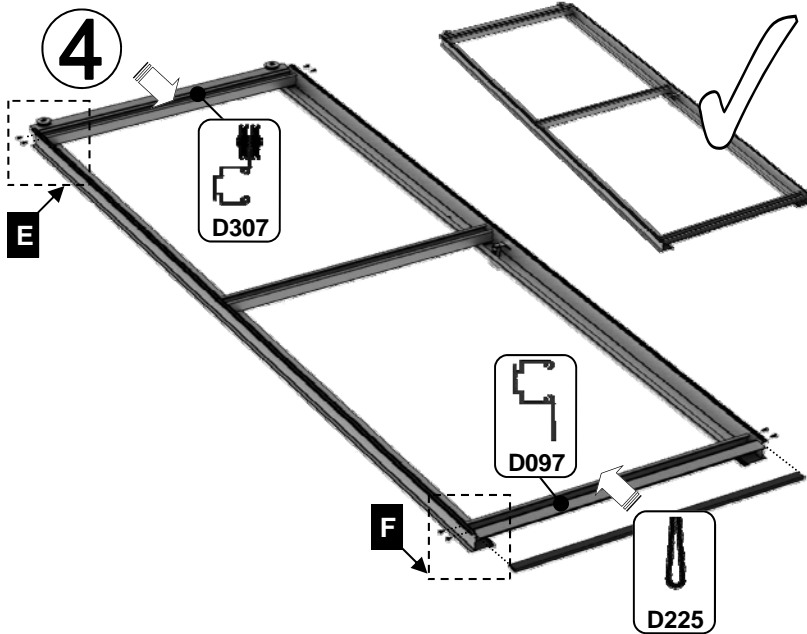
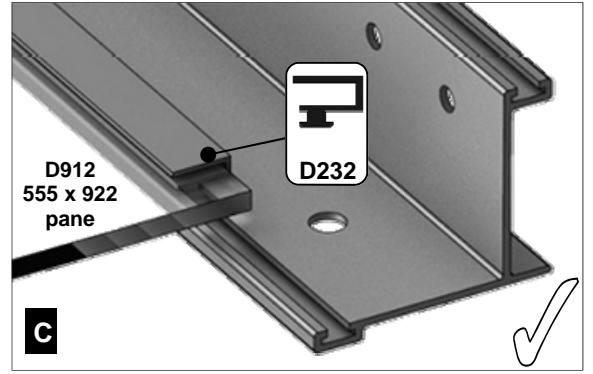
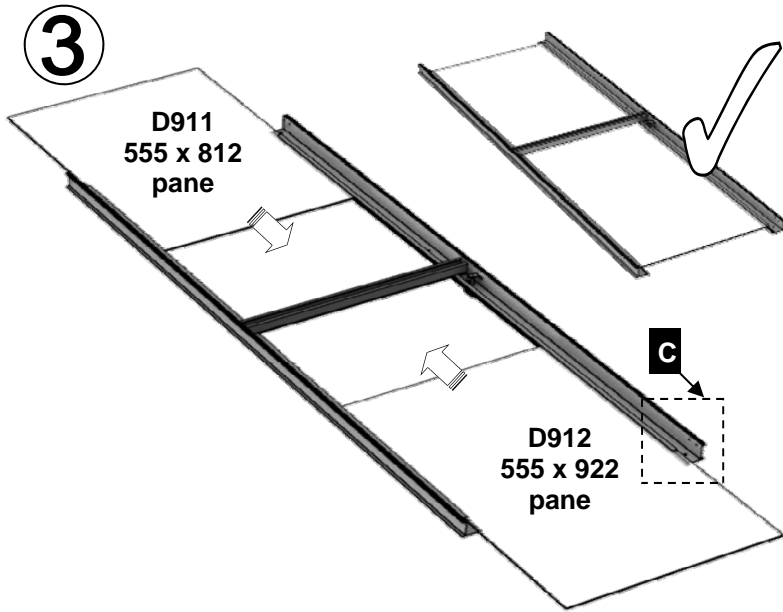
	Part No		mm	Q	Part No		mm	Q
Right Hand opening	D090 + D347 lock = D301		1824	1	D232		905	2
Left Hand opening	D091 + D347 lock = D302				D233		797	2
Right Hand opening	D094		1824	1	P053		N/A	1
Left Hand opening	D093				D225		610	1
	D096 + D217 wheel = D307		611	1	D840B		4000	1
	D095		611	1	D263 PACK		N/A	7
	D097		611	1			N/A	7
					D260 PACK		N/A	12

D355 - Right Hand opening door shown as an example throughout. On this model this door would be fitted on the left gable as you look at the wall and slide from the wall towards the gutter.





PART No	Section	Size (mm)
D913		2030
D944		1294
D953		1923
D960		2140
D969		140
D971		250
D814		1883
D952		1923
D943		1294
D836		1883
D914		2030
D945		1294
D954		1923
D959		2140
D970		140
D972		250

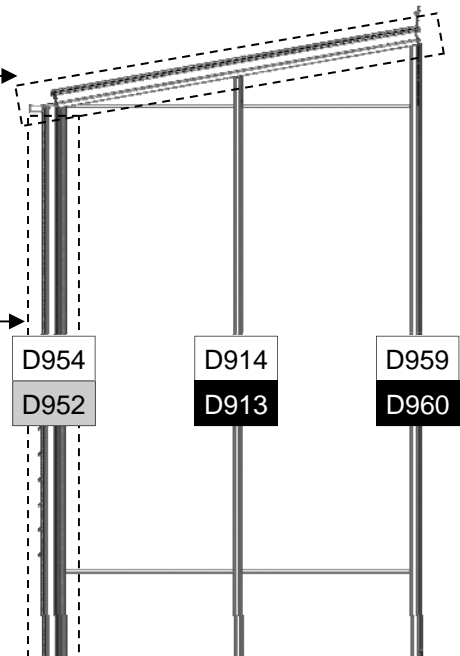
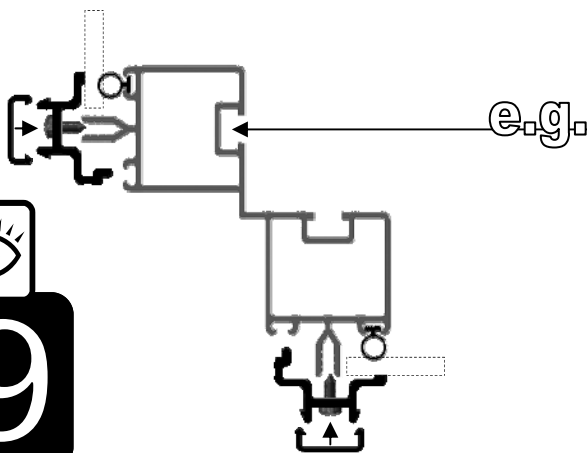
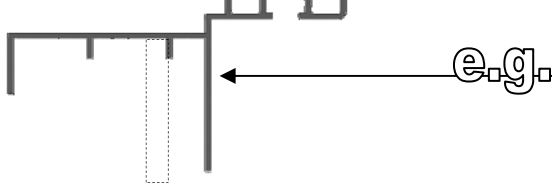
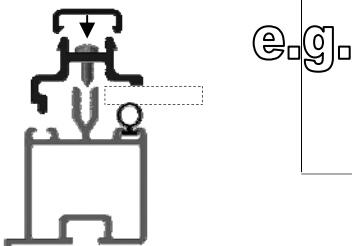
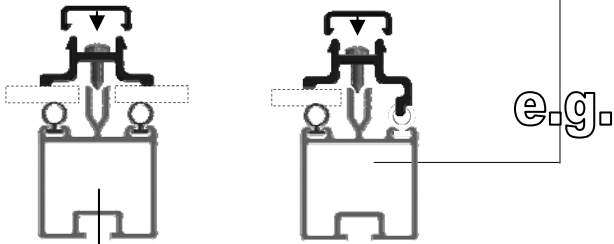
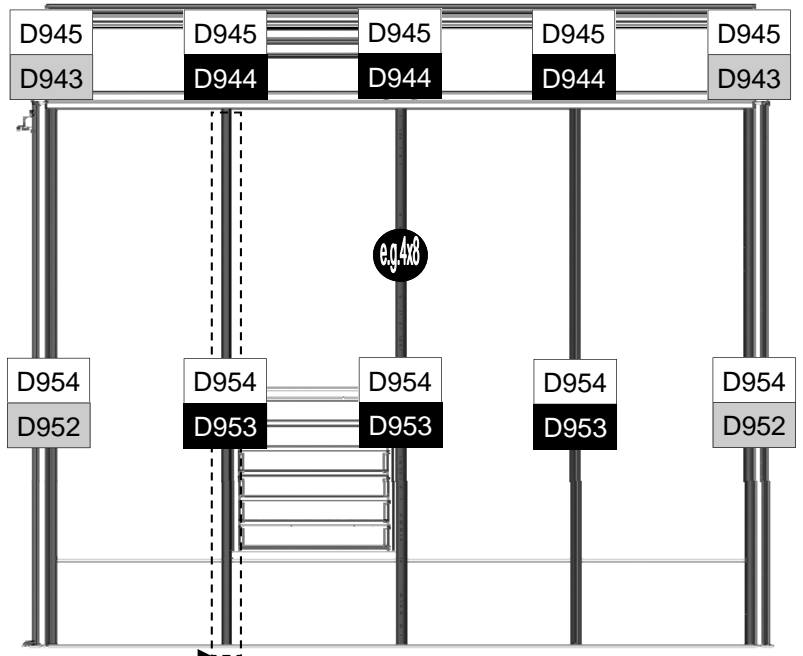
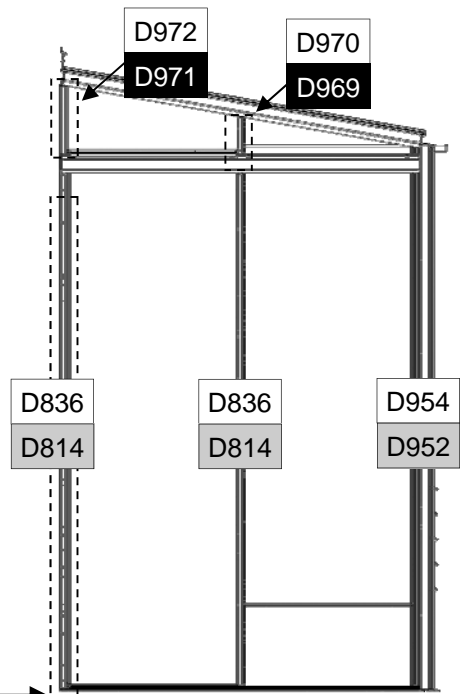
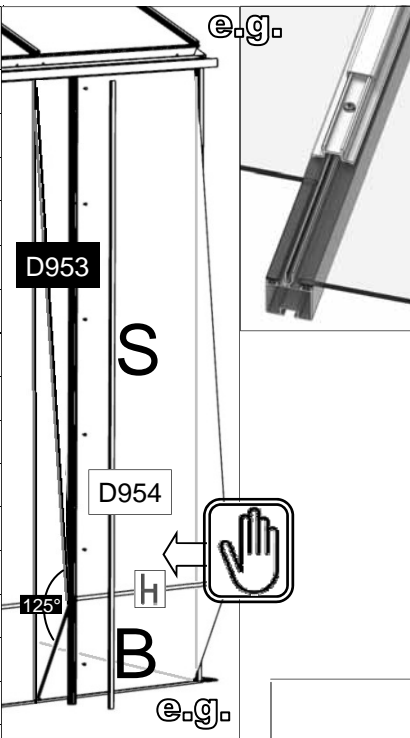



4' LEAN-TO TOUGHENED GLASS

e.g. 4ft x 8

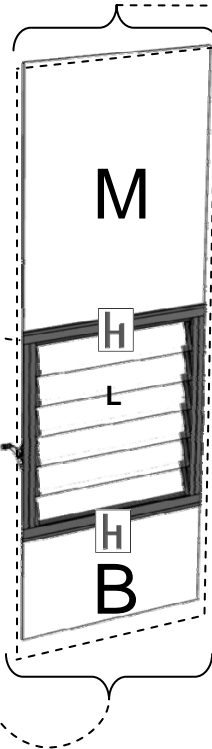
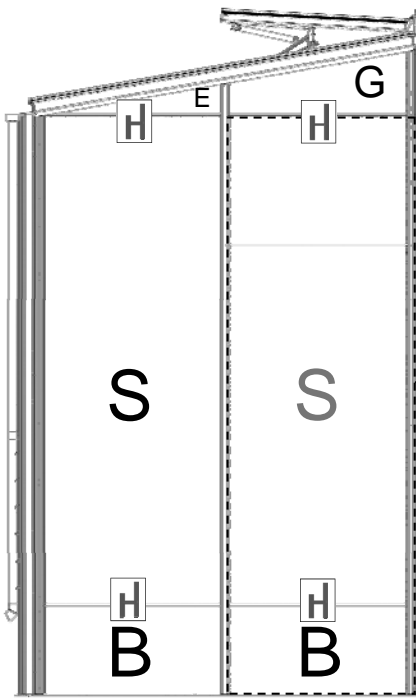
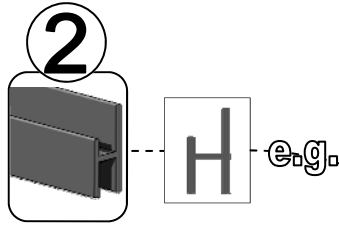
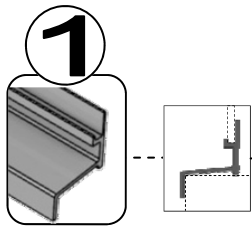
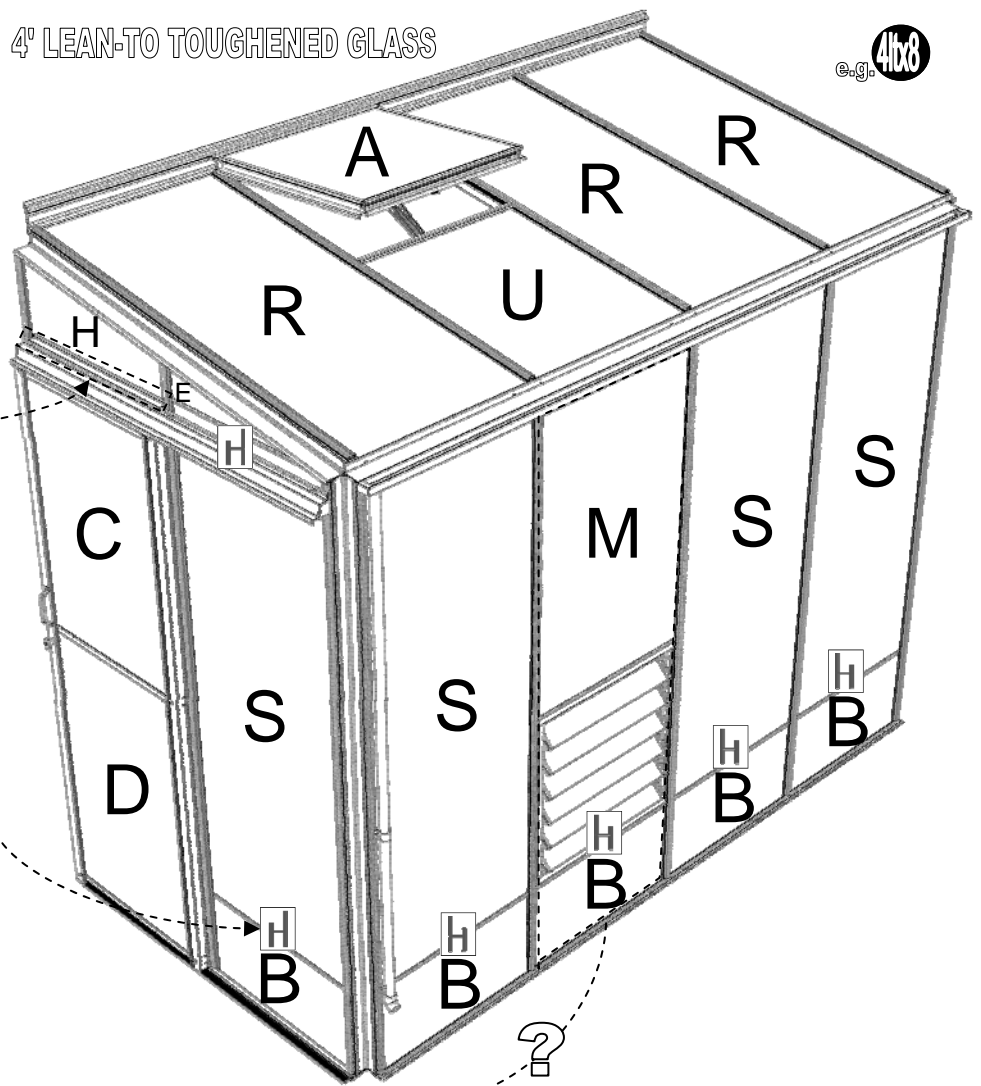

PART No		Size (mm)	4'	6'	8'	10'	12'
D519	S	610 X 1628	4	5	6	7	7
D868	R	610 X 1303	1	2	3	3	4
D869	U	610 X 685	1		2		
D1208	A	610 X 610	1		2		
D1254	B	610 X 305	5	6	7	8	9
D911	C	555 X 812	1				
D912	D	555 X 922	1				
D966	E	ANGLE	2				
D967	G	ANGLE	1				
D968	H	ANGLE	1				
D222/B		590 long	1				
D101 / ROSEPS	H	610 long	8	9	10	11	12

1

D521	M	610 X 1016	1
D729	L	525 X 100	6
D101 / ROSEPS	H	610 long	1

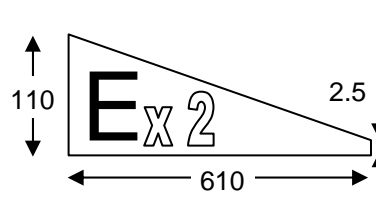
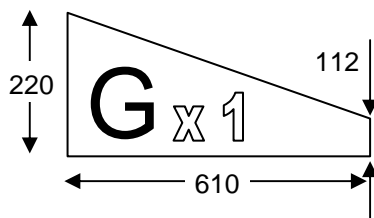
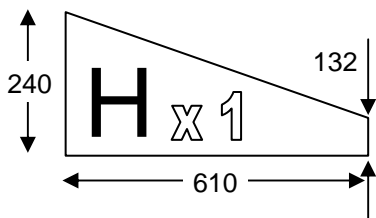

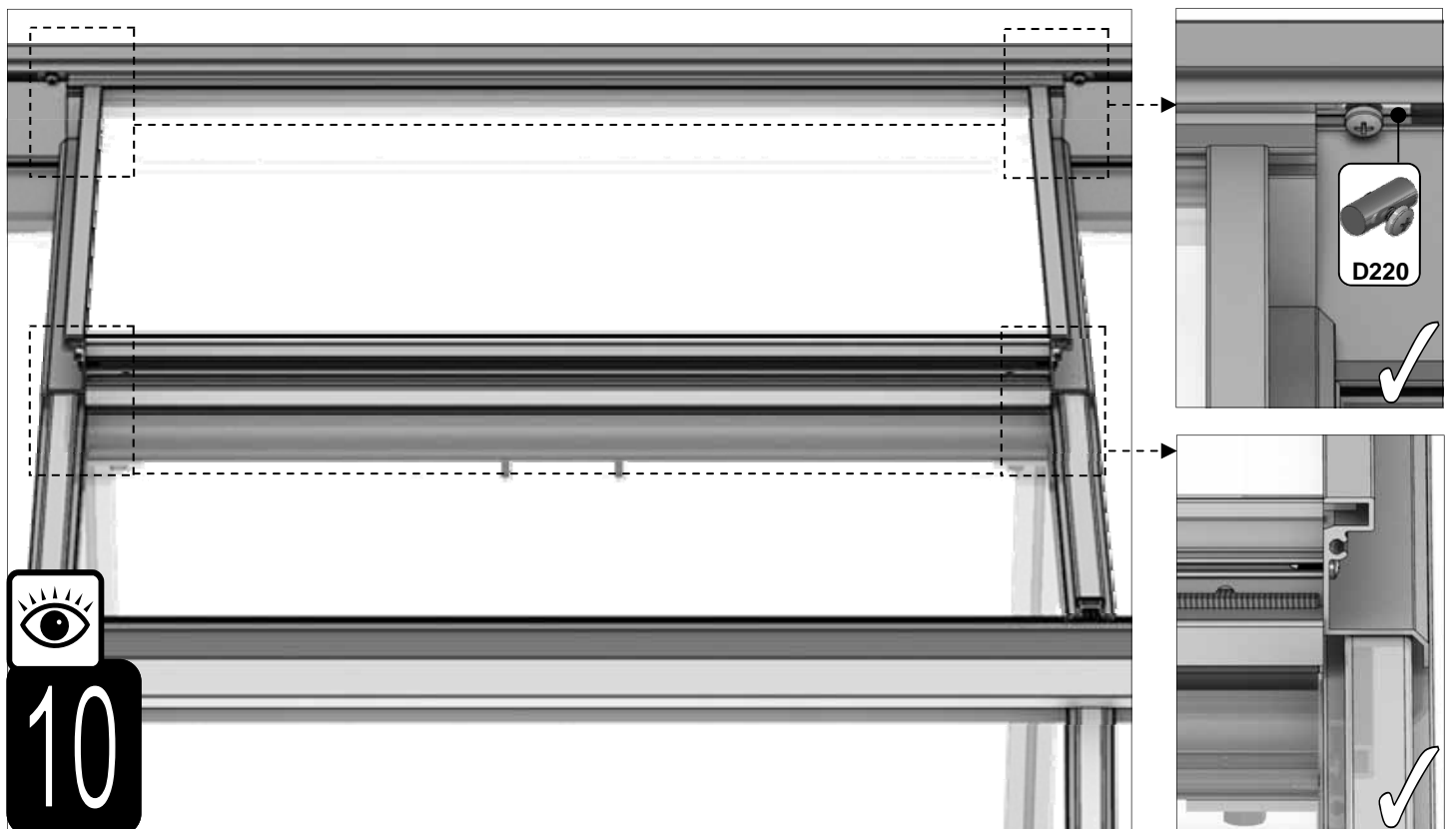
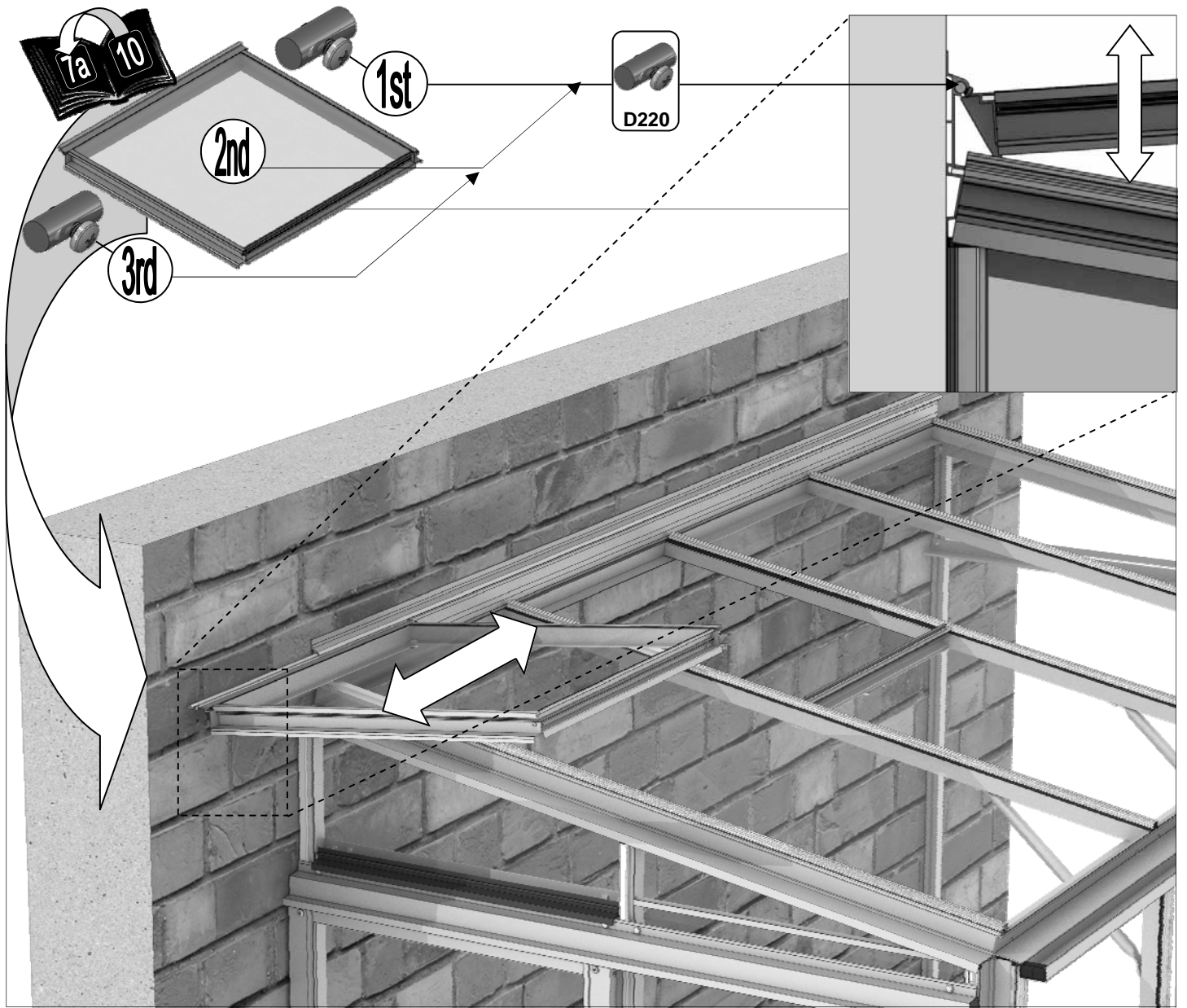

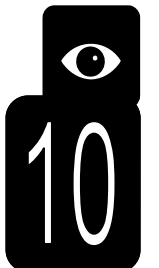
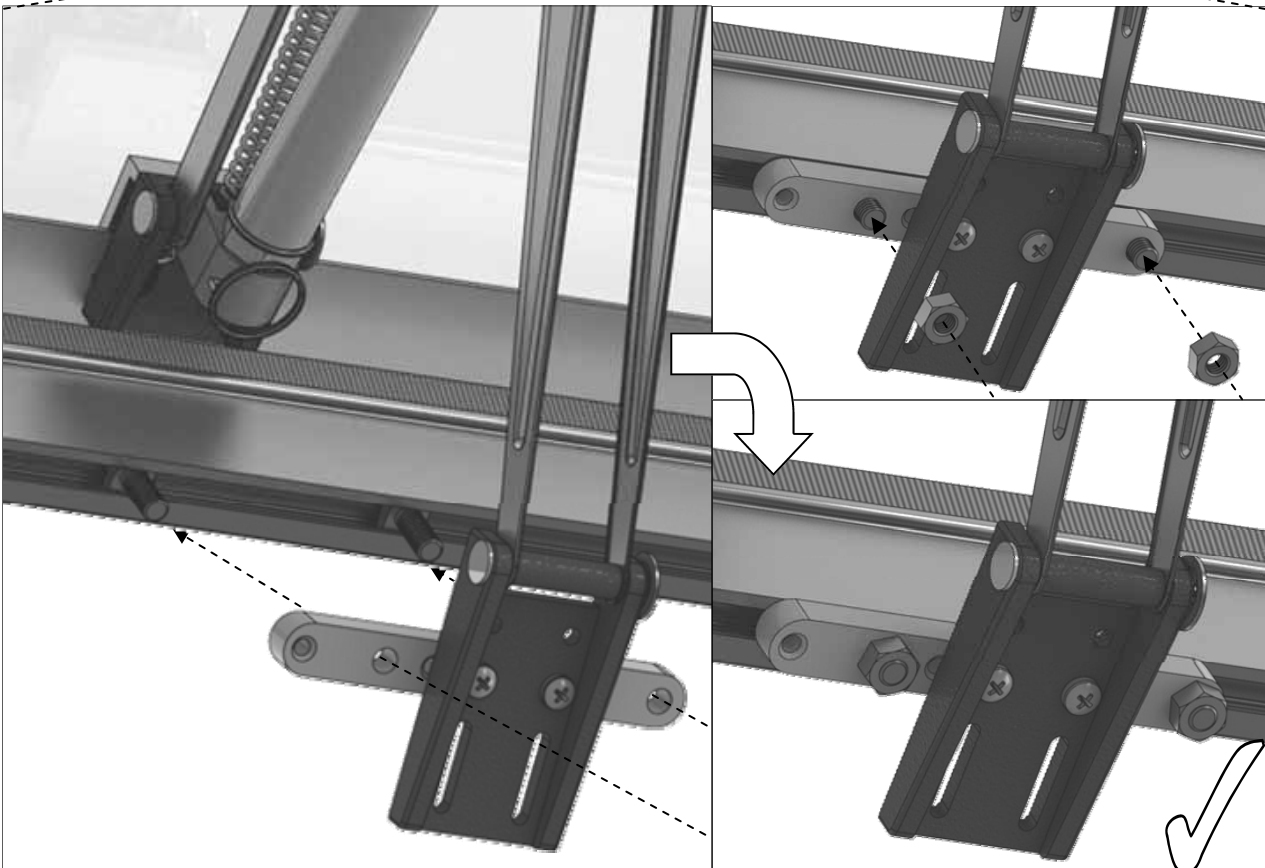
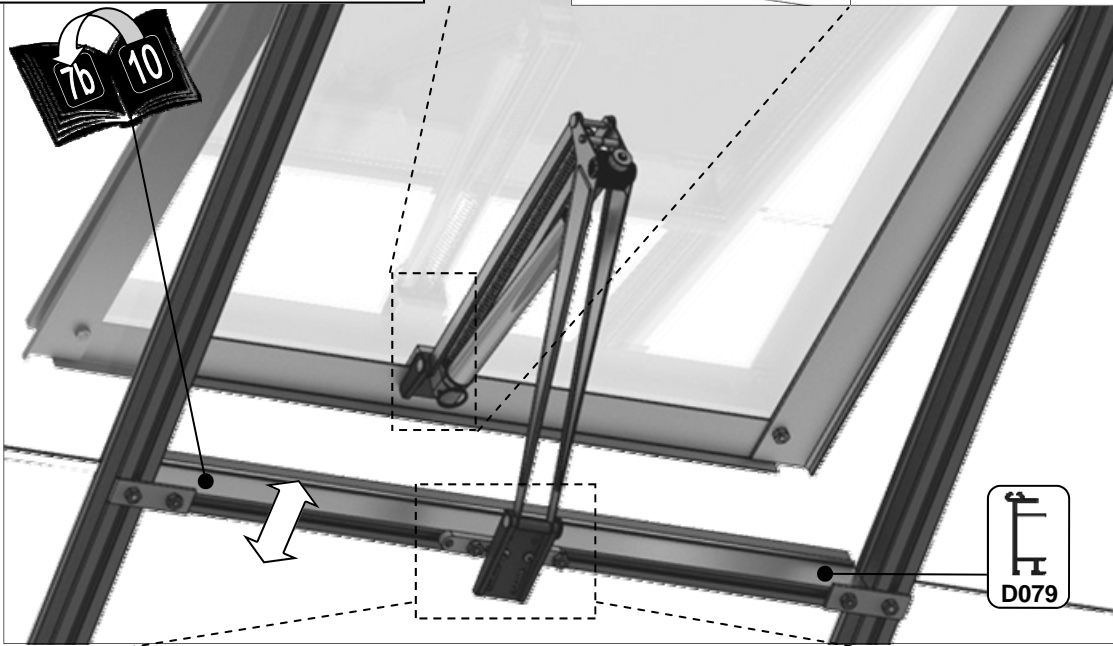
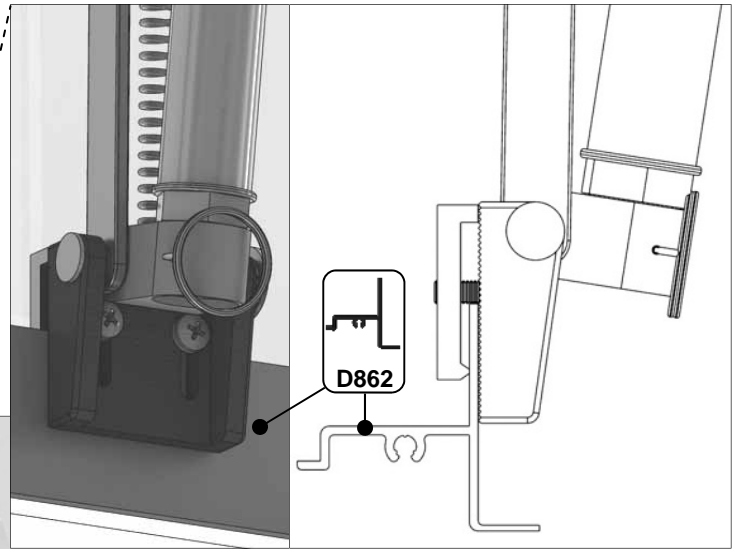
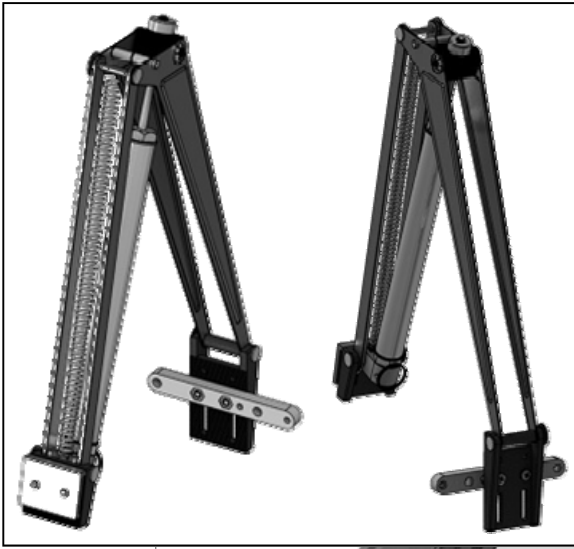

Part No		mm	Q
D864		590	1
D084		1270	1
D083		1270	1

Part No		mm	Q
D163		90	2
D845			2
SY-BOLM6X15			8
SYNUTM6			8

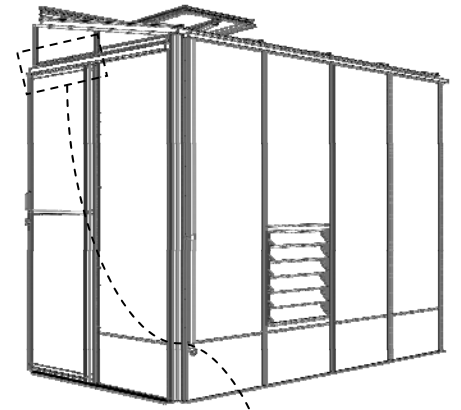

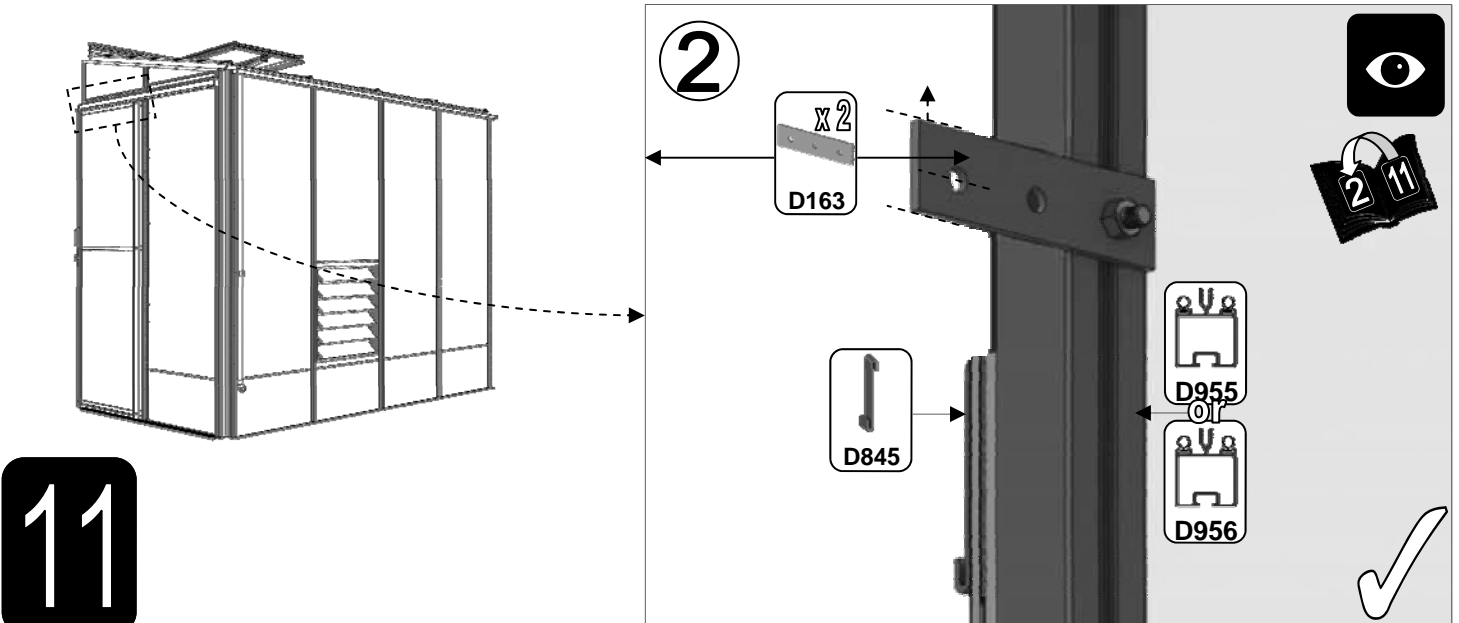
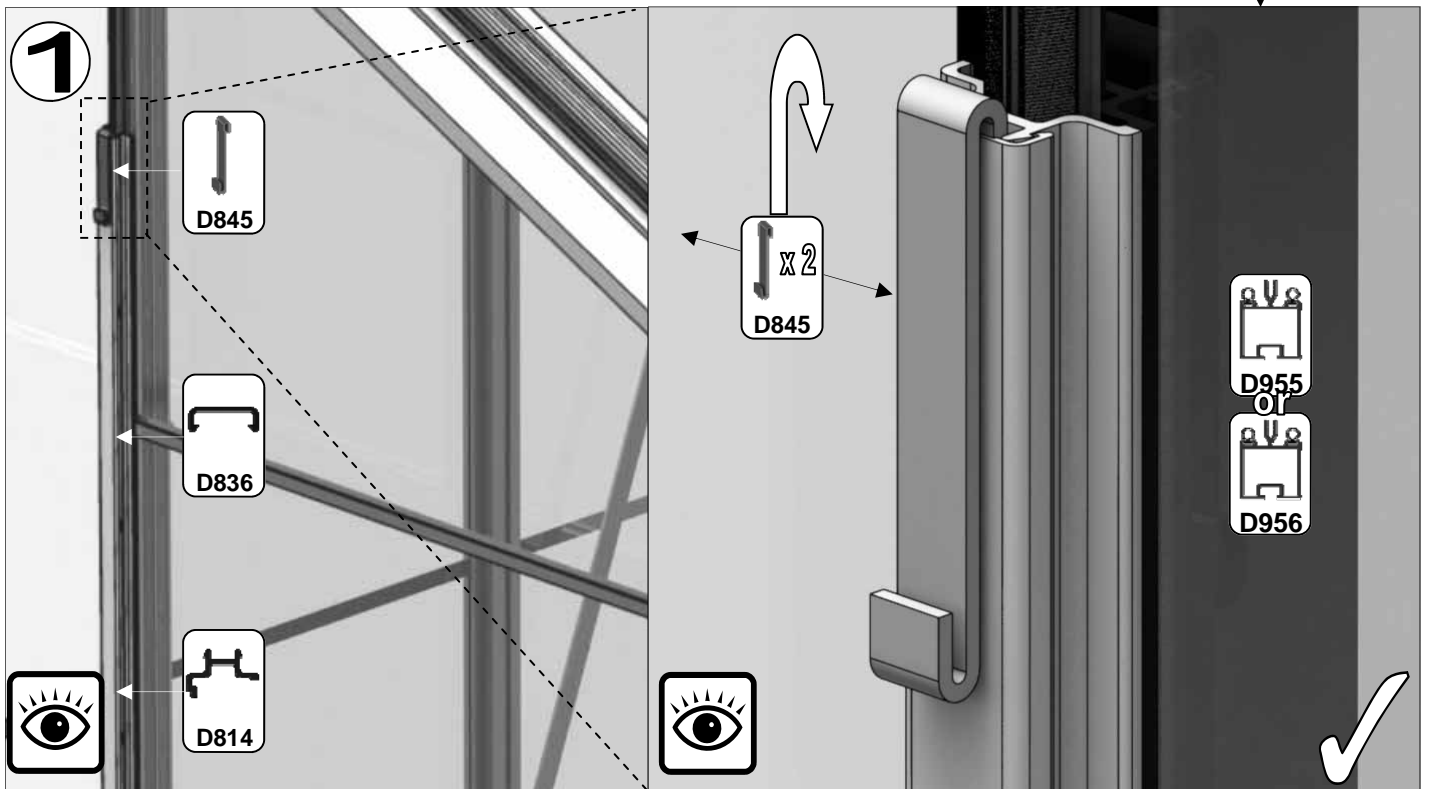

D355 - Right Hand opening door shown as an example throughout. On this model this door would be fitted on the left gable as you look at the wall and slide from the wall towards the gutter.

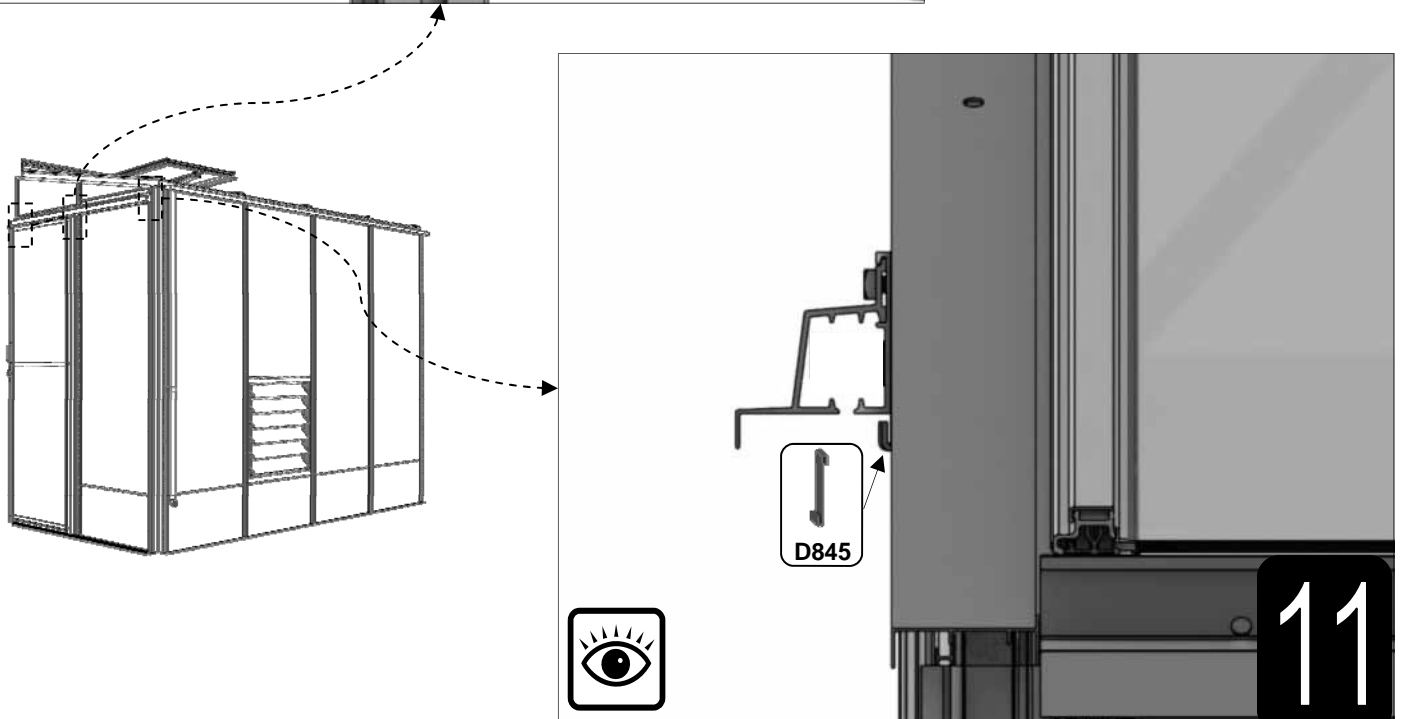
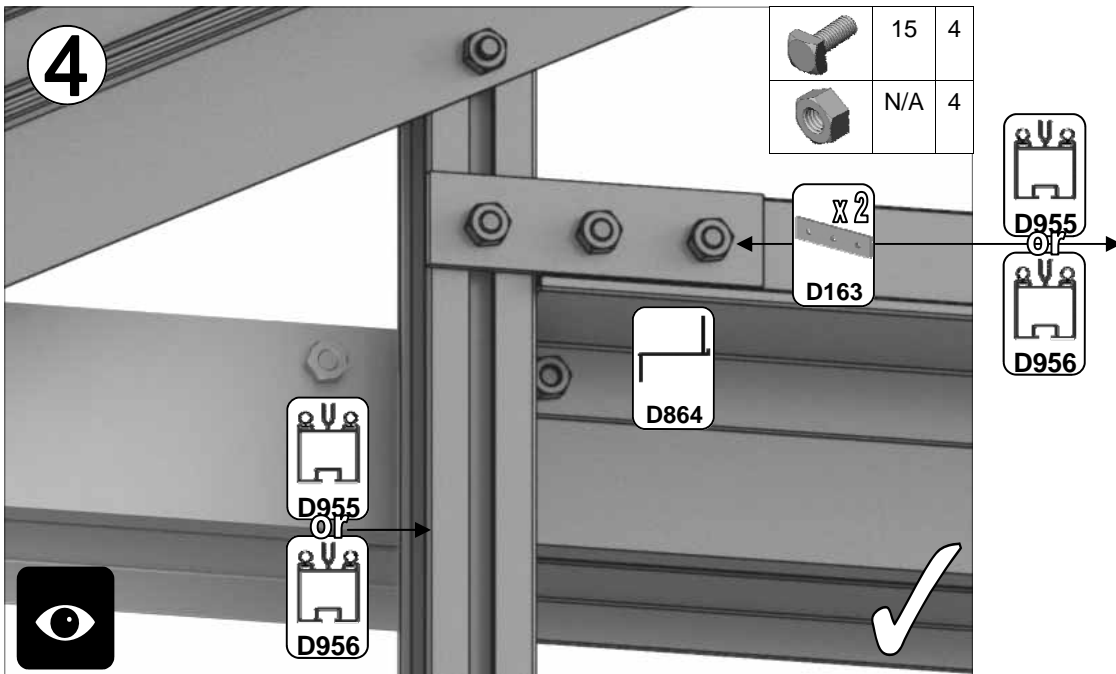
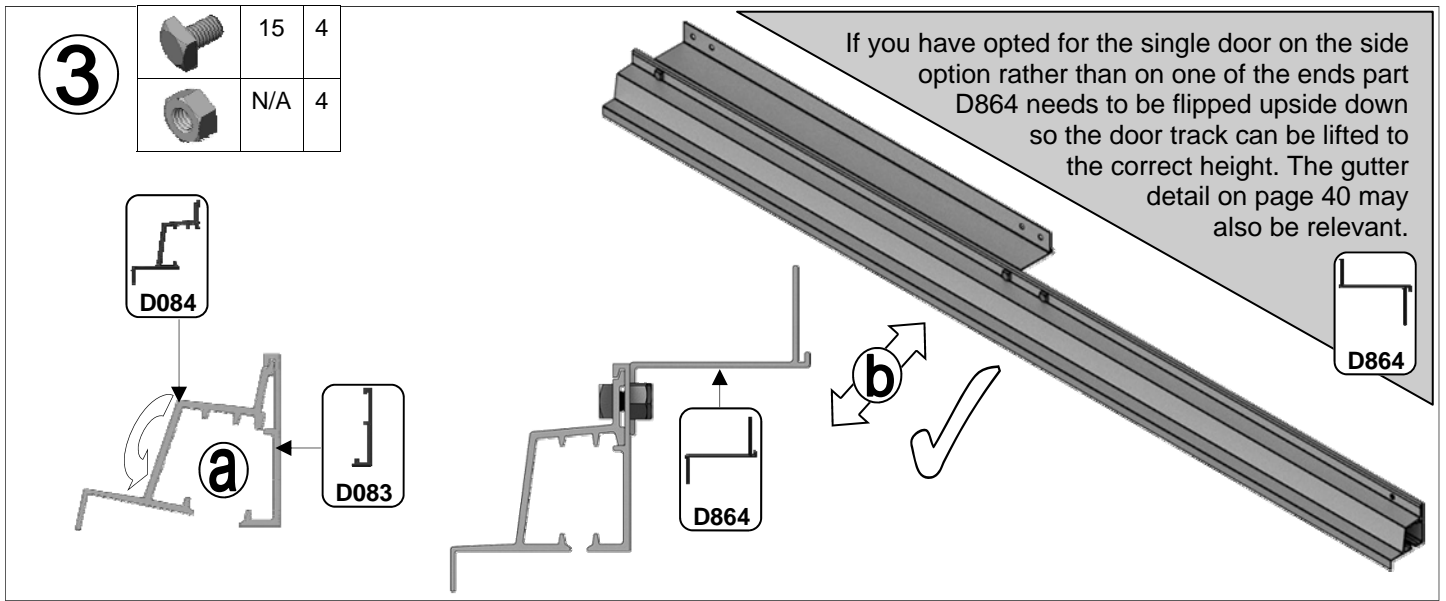

11



Part No		Q
D860		1
D087		1

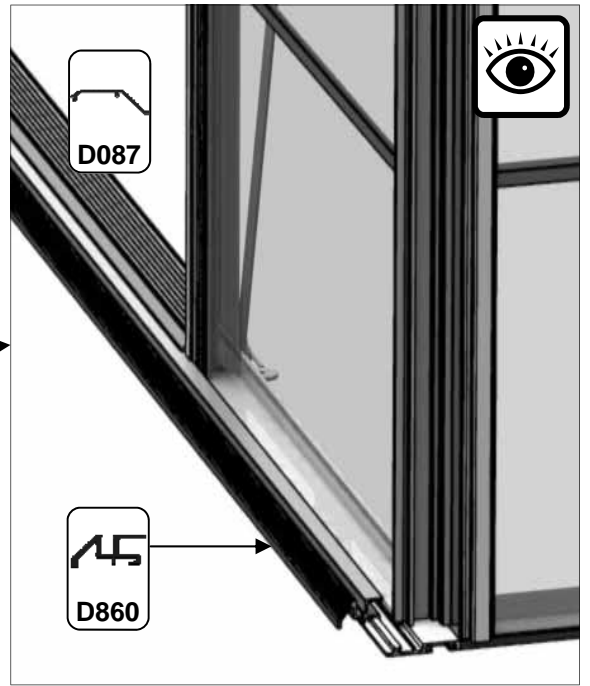
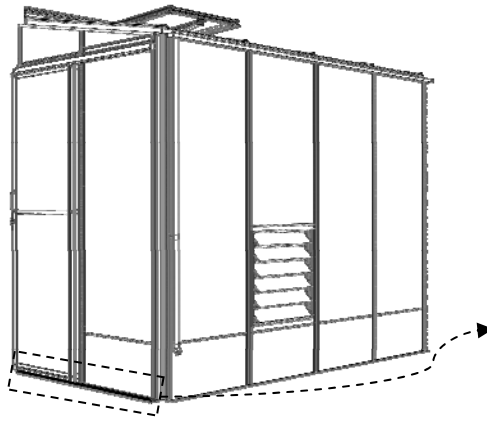

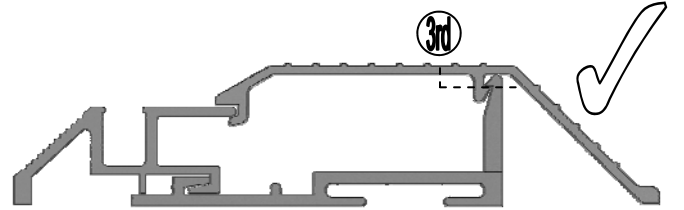
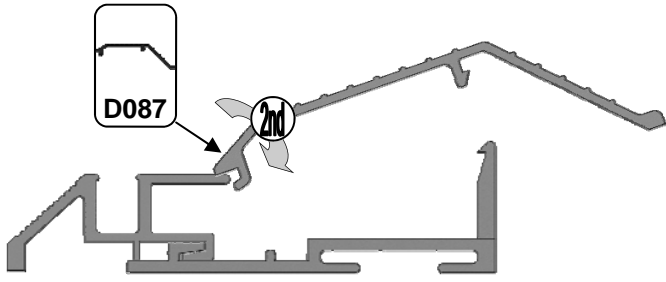
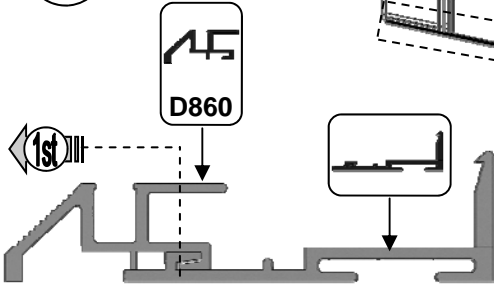

5

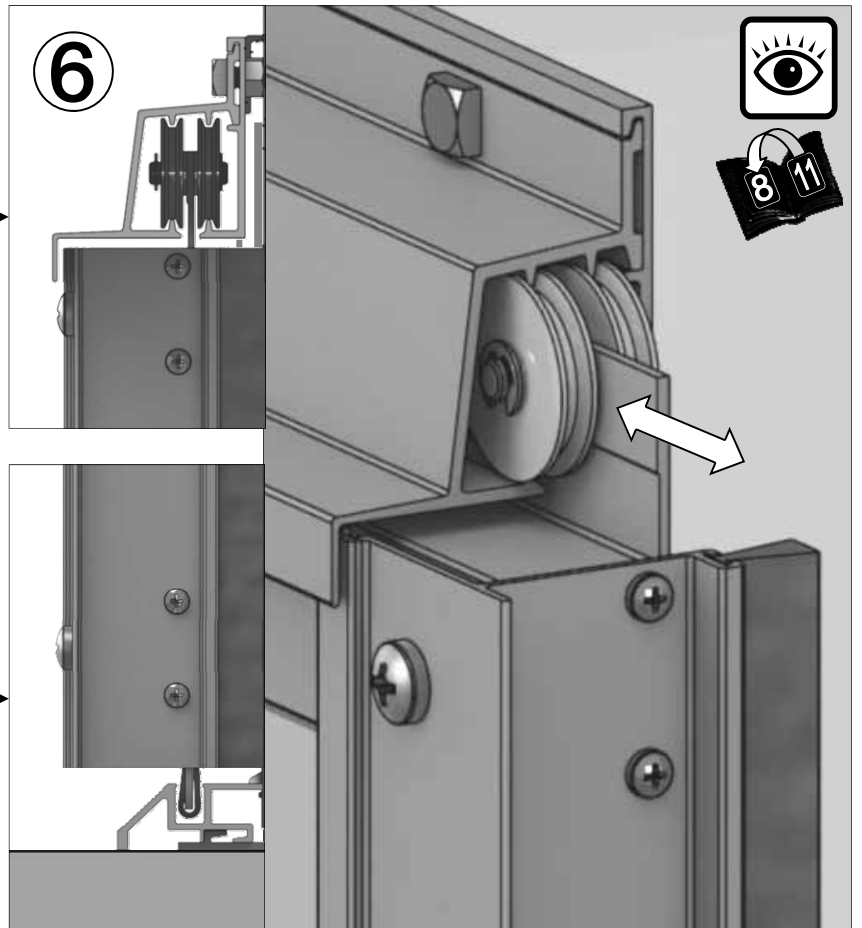
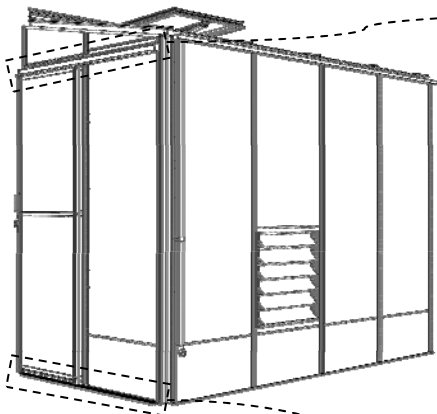

6



11

Part No		Q
D842		1
SYNUTM6		2

7

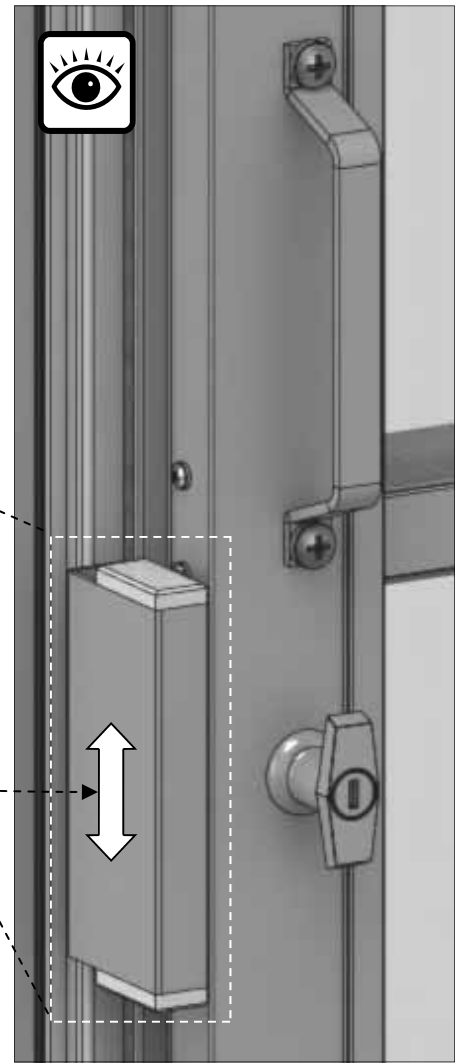
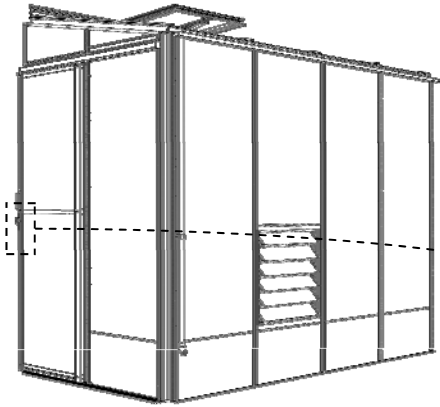
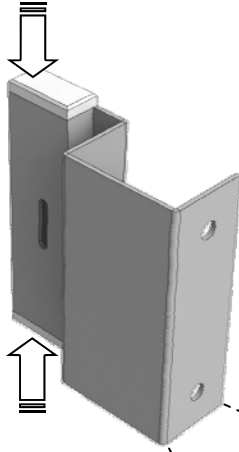

Part No		Quantity
FS6018		1
D312		2
D204L /B		1
D204R /B		1

8

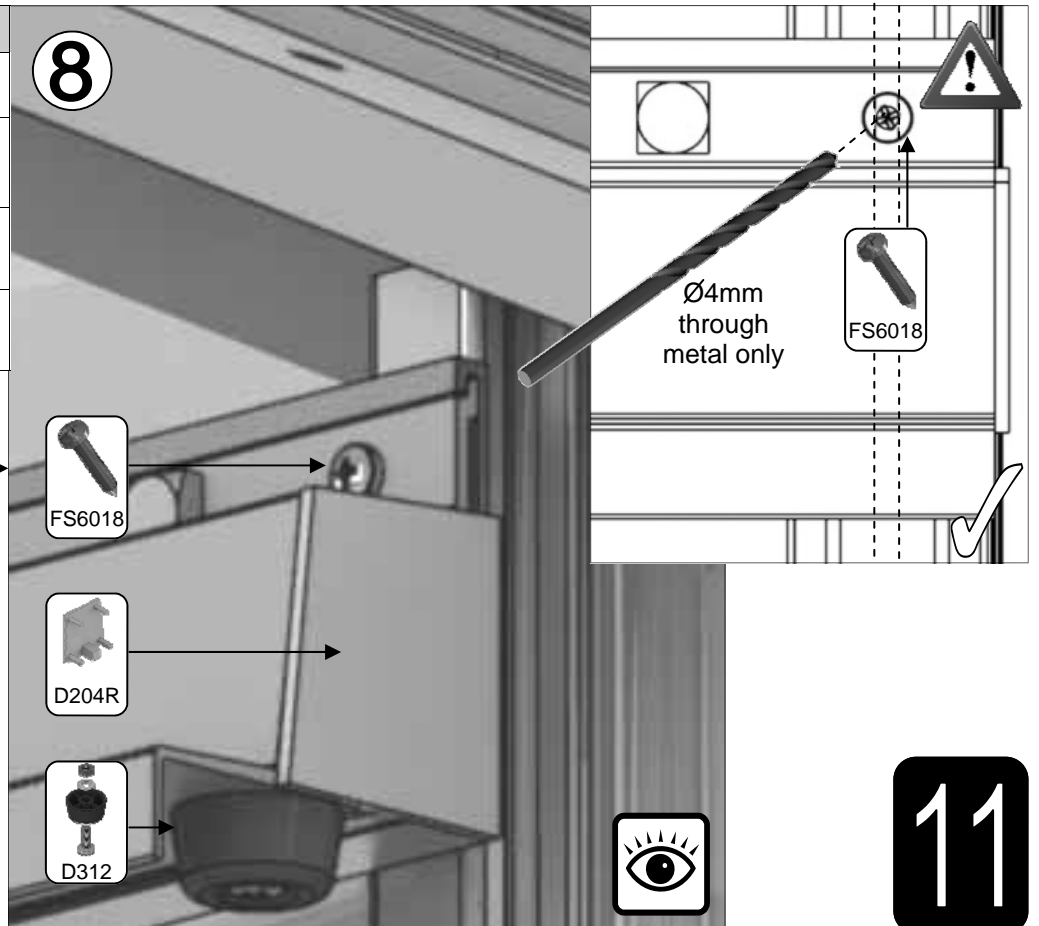

11

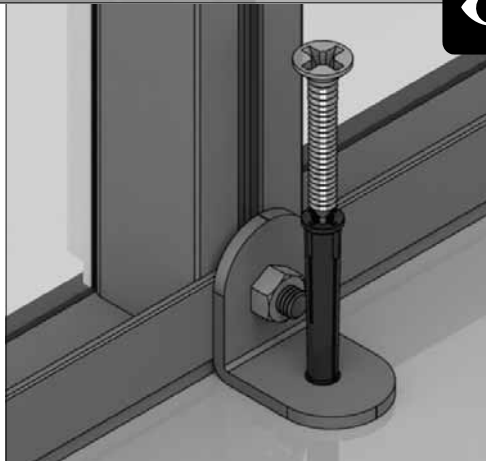
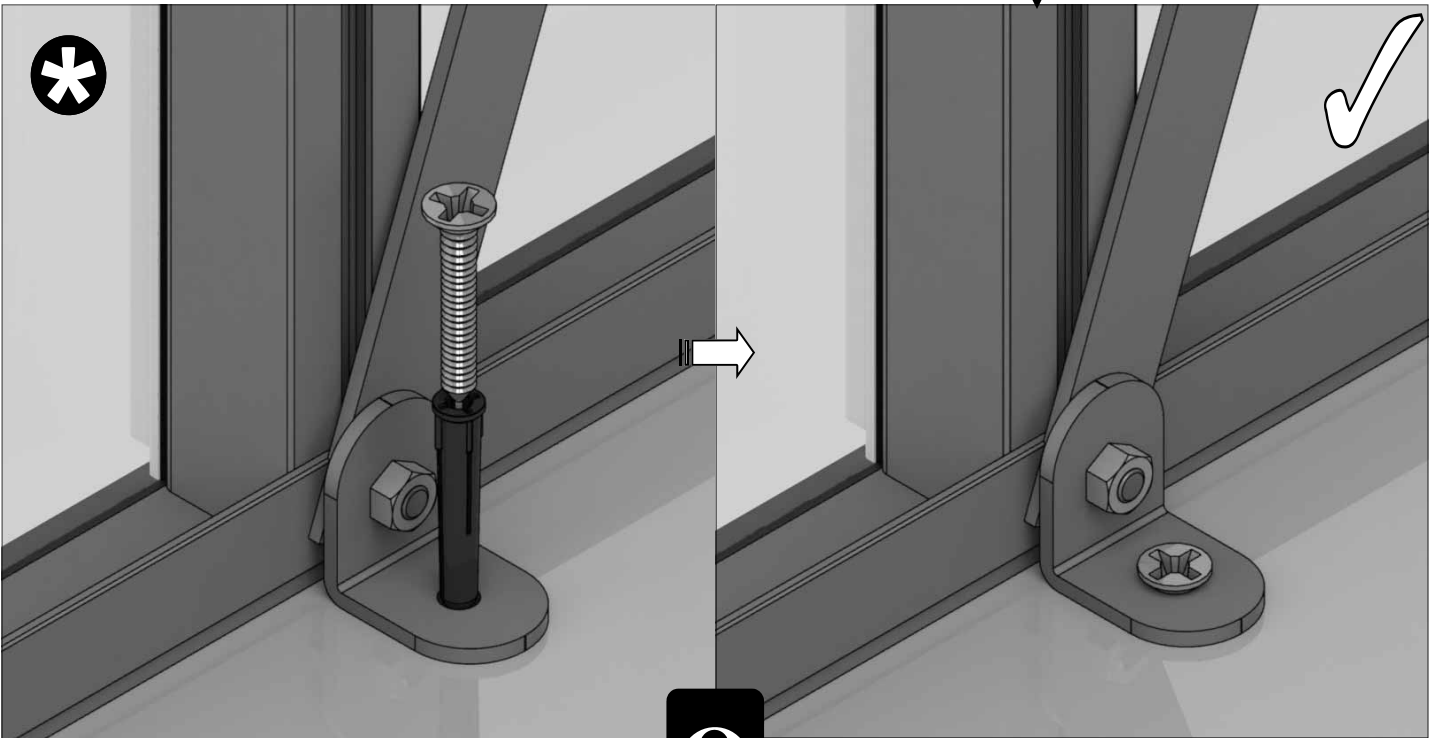
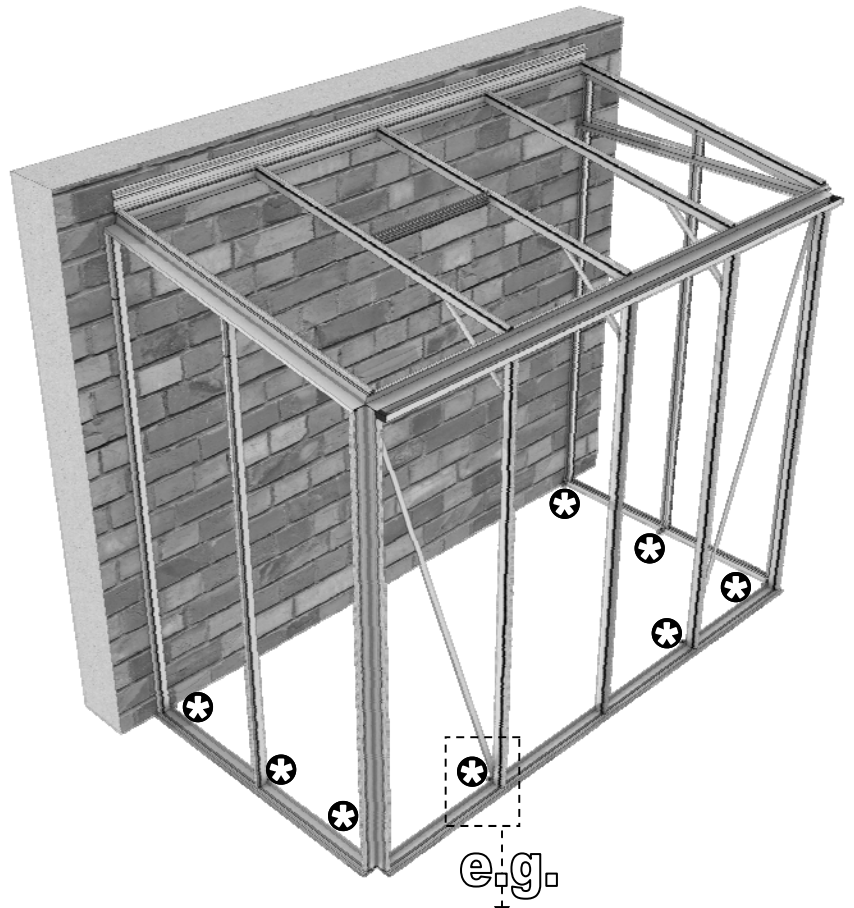
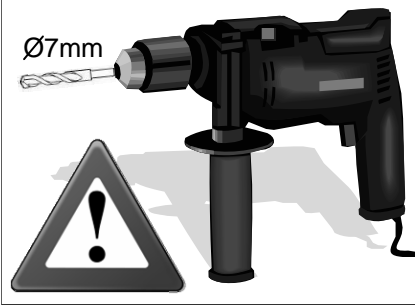
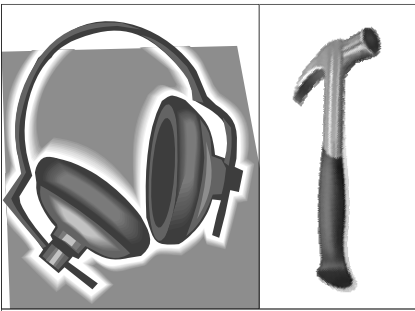

12

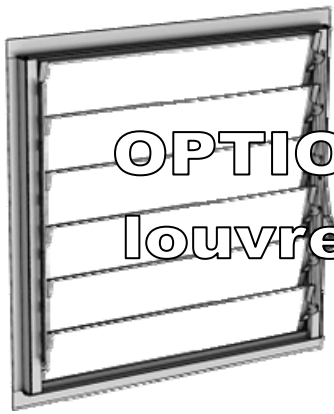

OPTIONAL
louvre = {

Part No		mm	Quantity
D168L		552	1
D168R (handle)		552	1
D165		612	2
D166		552	2
FS6013		12	4

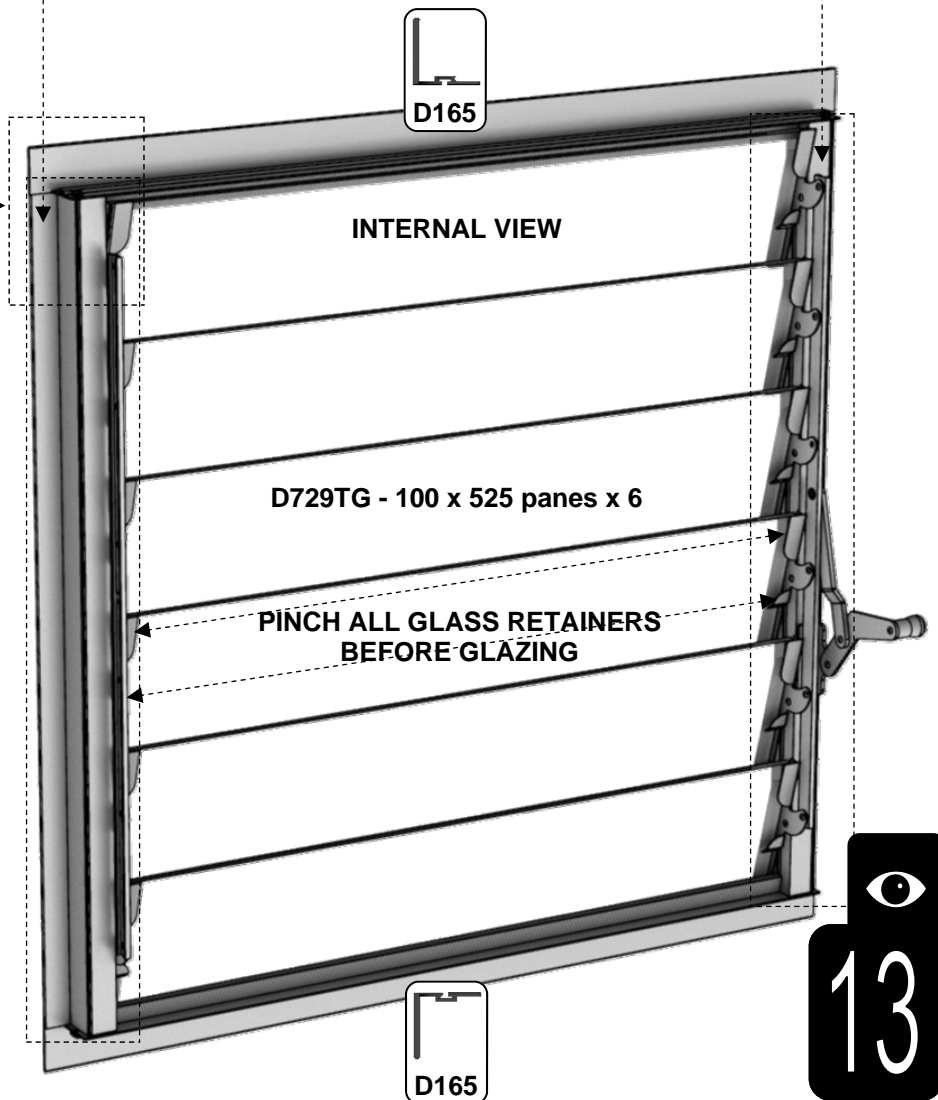
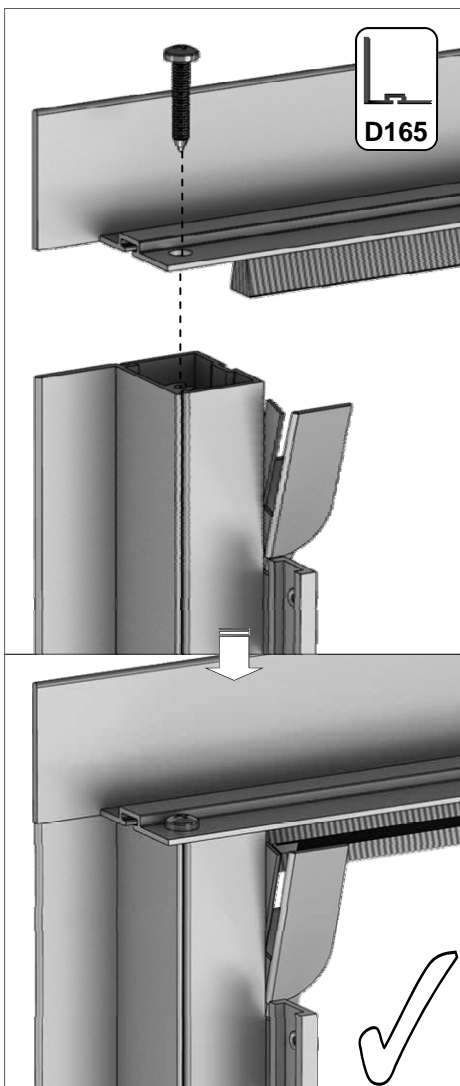
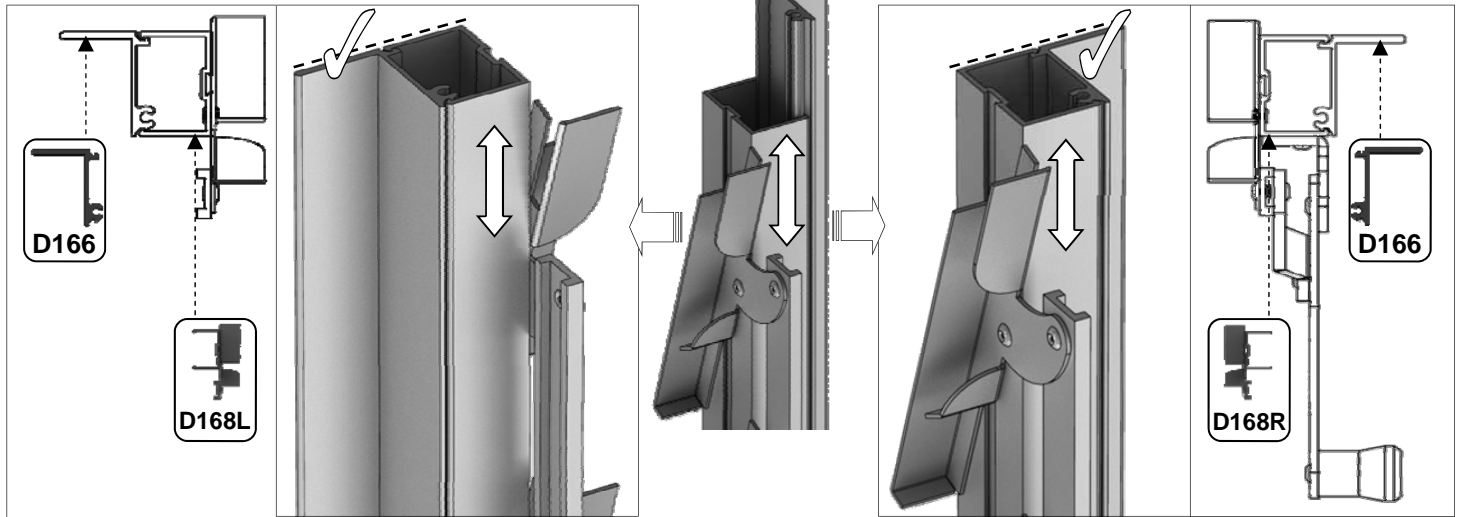

Example: 2x 4' **3** slat shelves 'ST0304' = 8' run

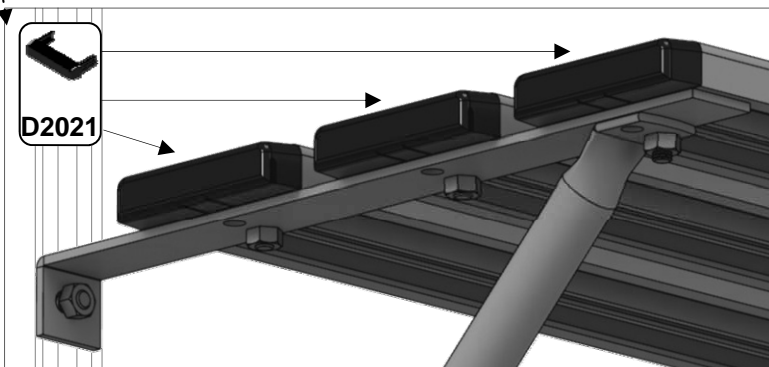
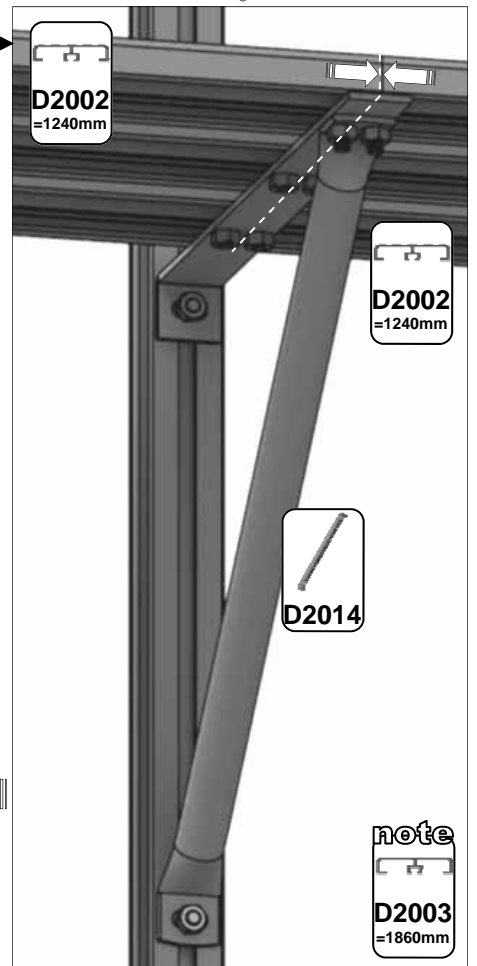
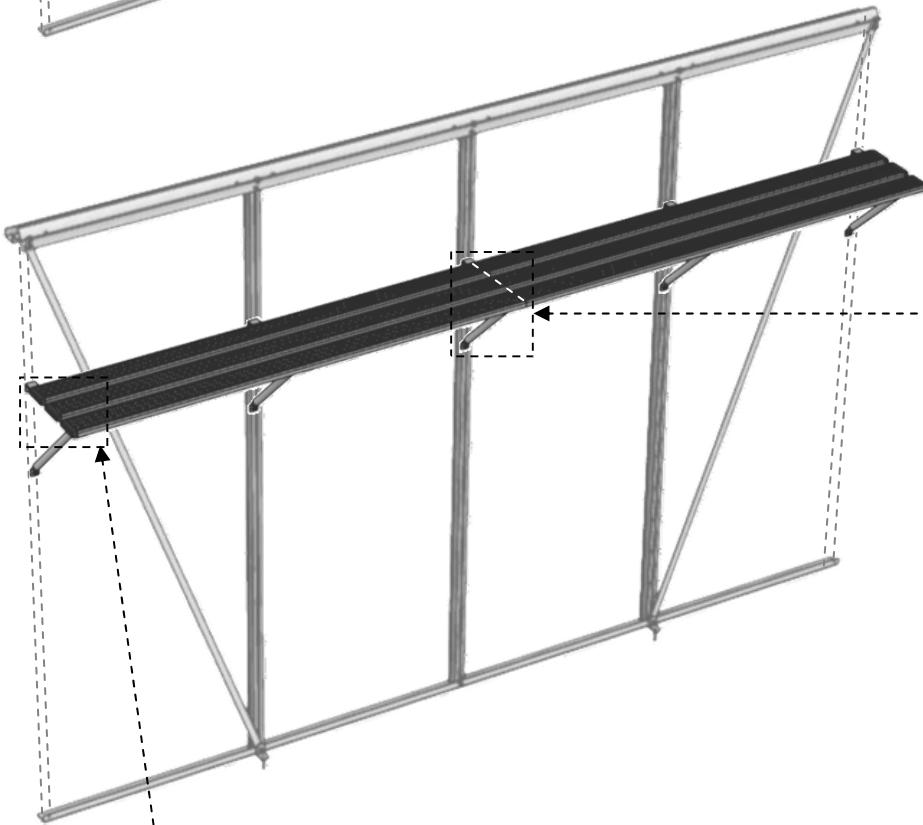
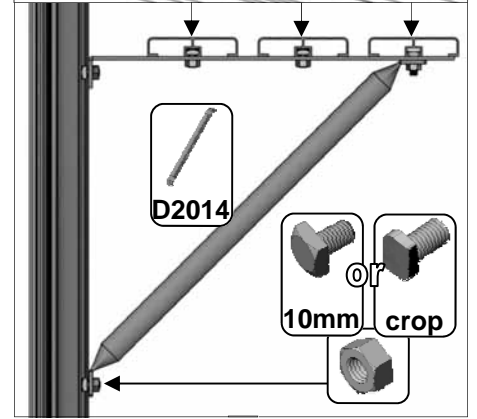
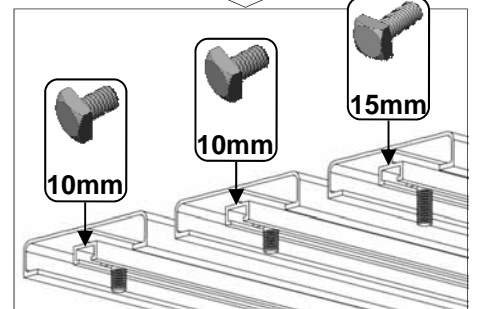
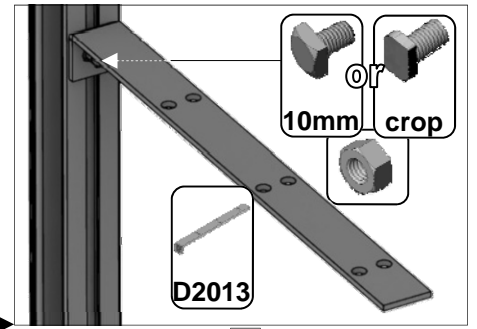
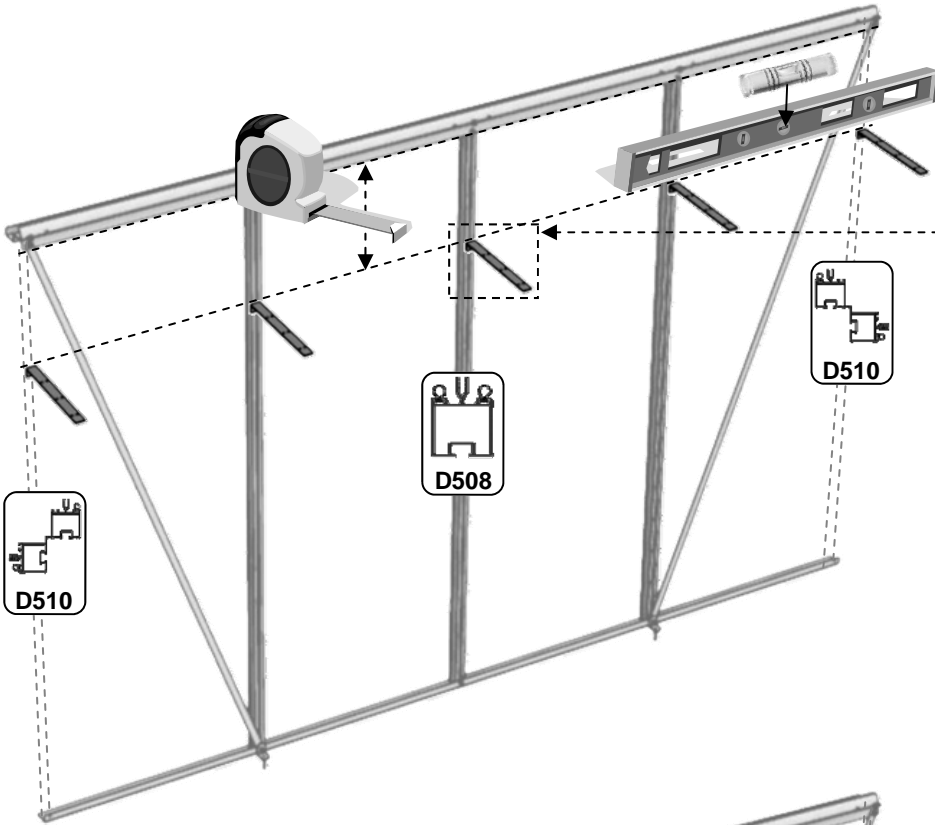

14

Example: 2x 4' **7 slat** staging 'ST0704' = 8' run

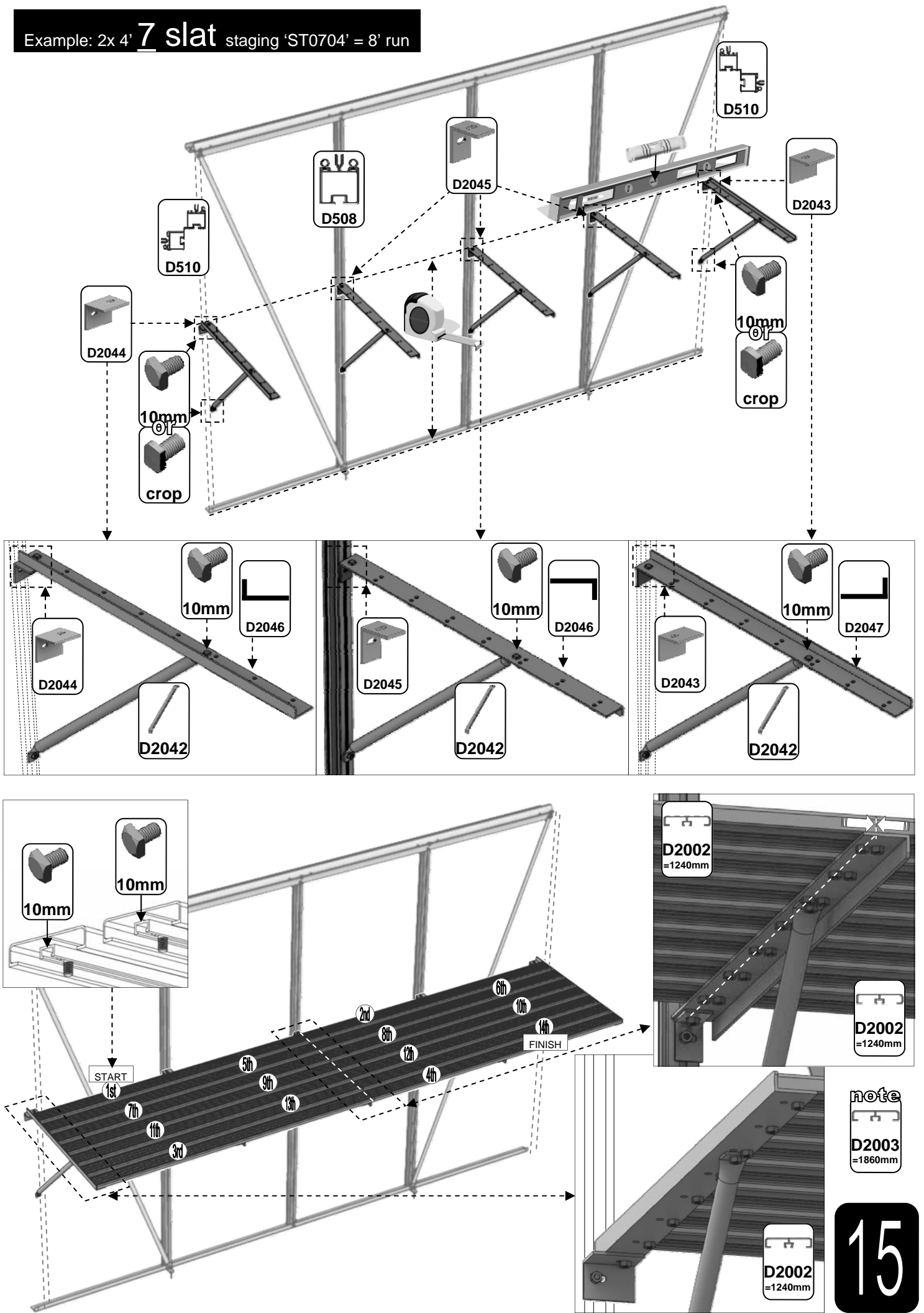

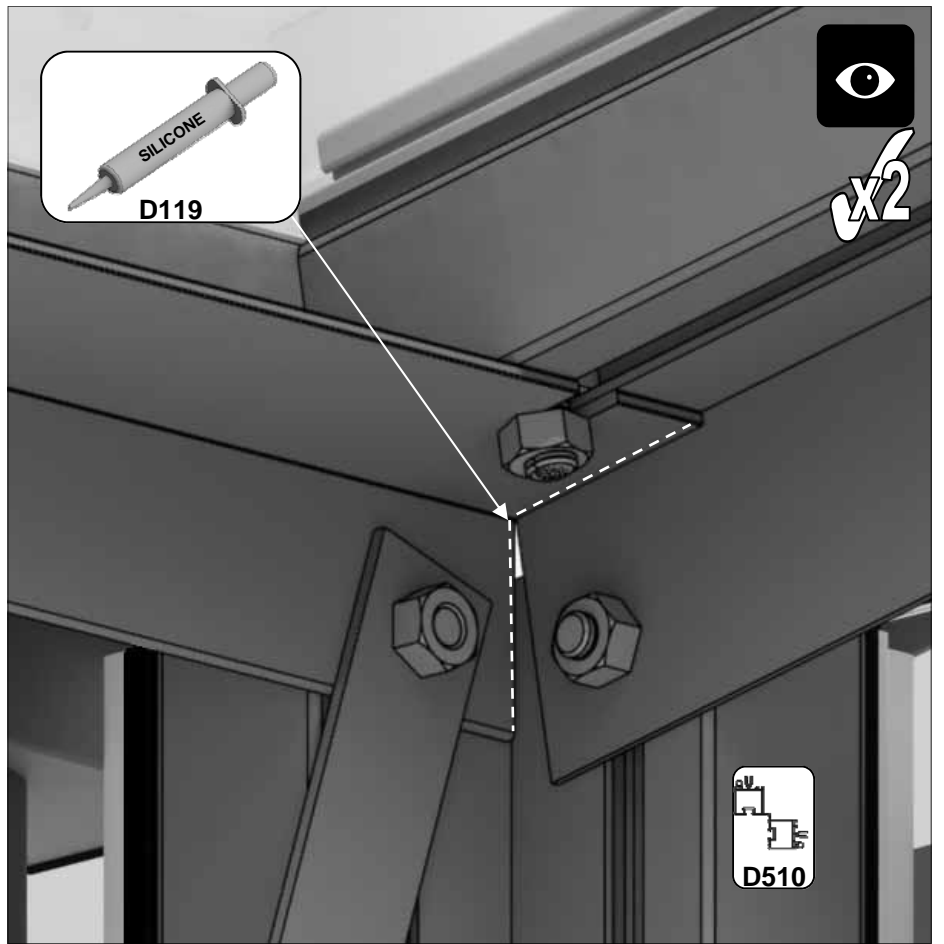
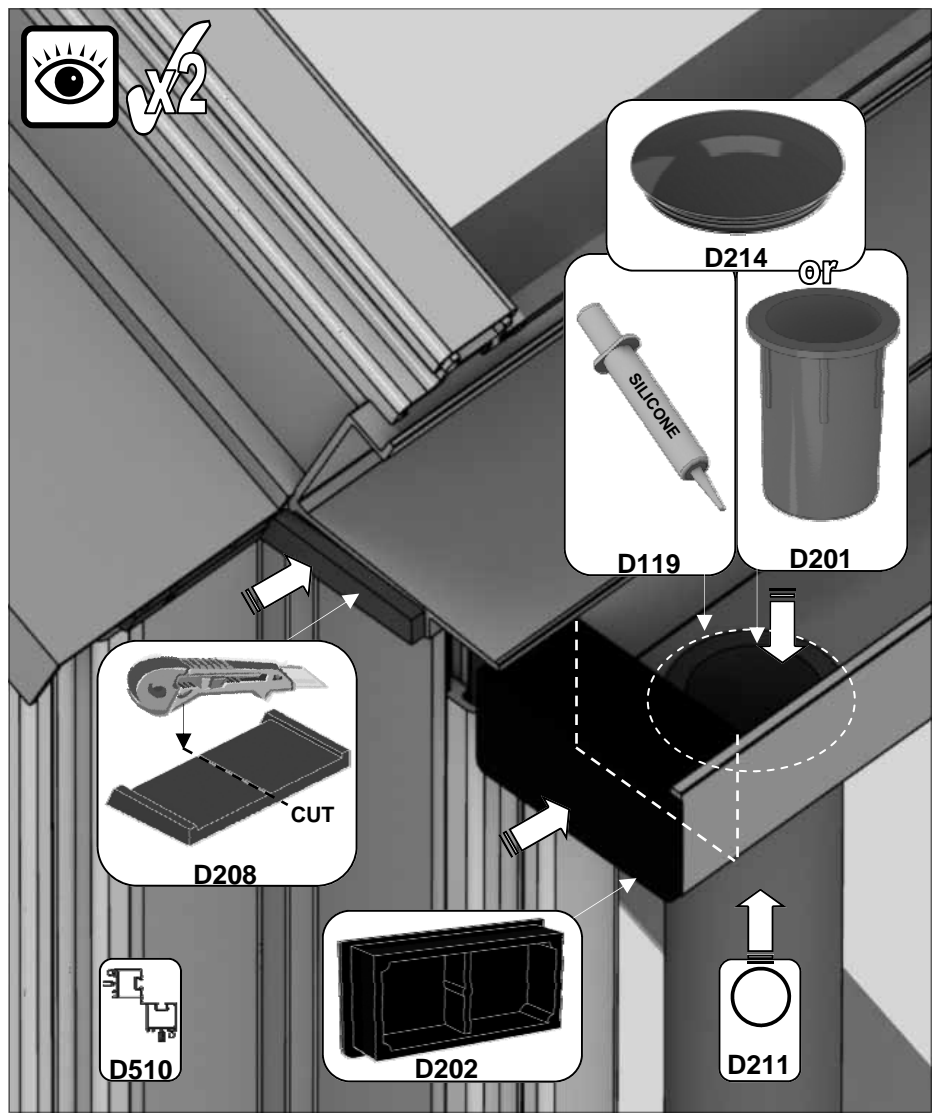
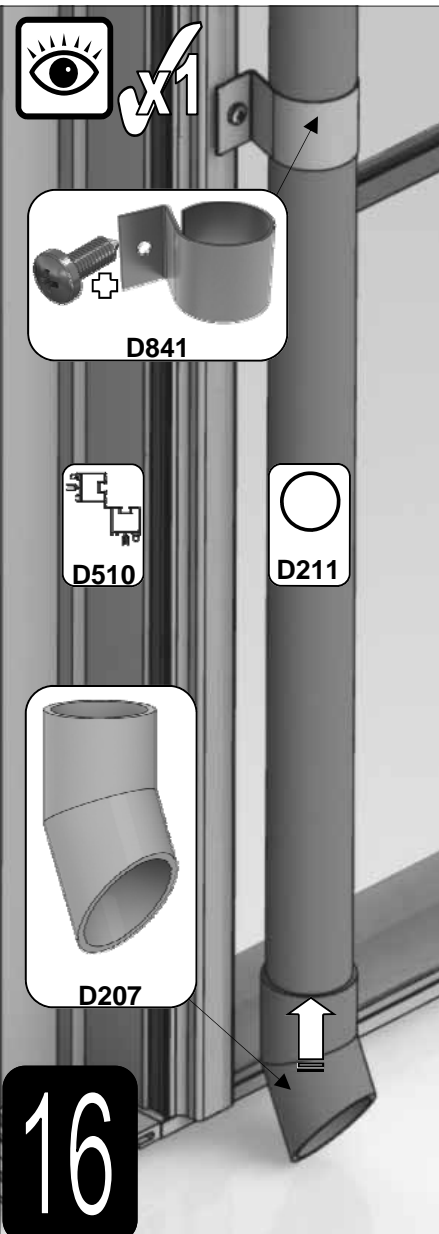
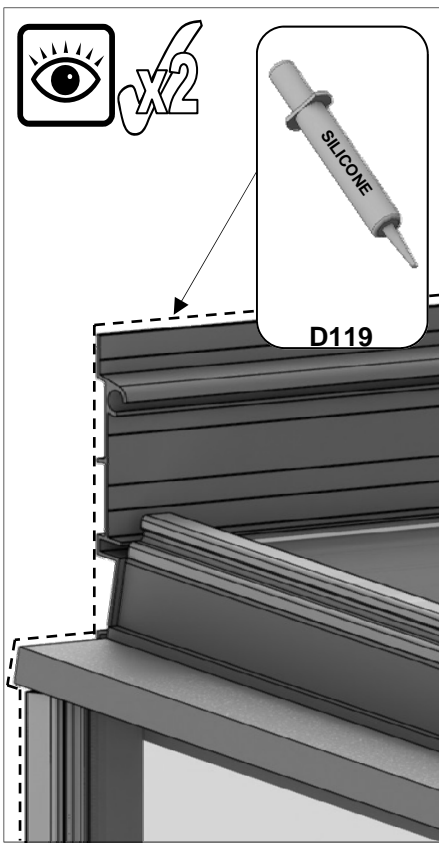

Part No		mm	Q
D512		1210	1
D086		2510	1
D085		2510	1

Part No		mm	Q
D522		50	1
D163		90	2
D150			1
D845			2
SY-BOLM6X15			13
SYNUTM6			13

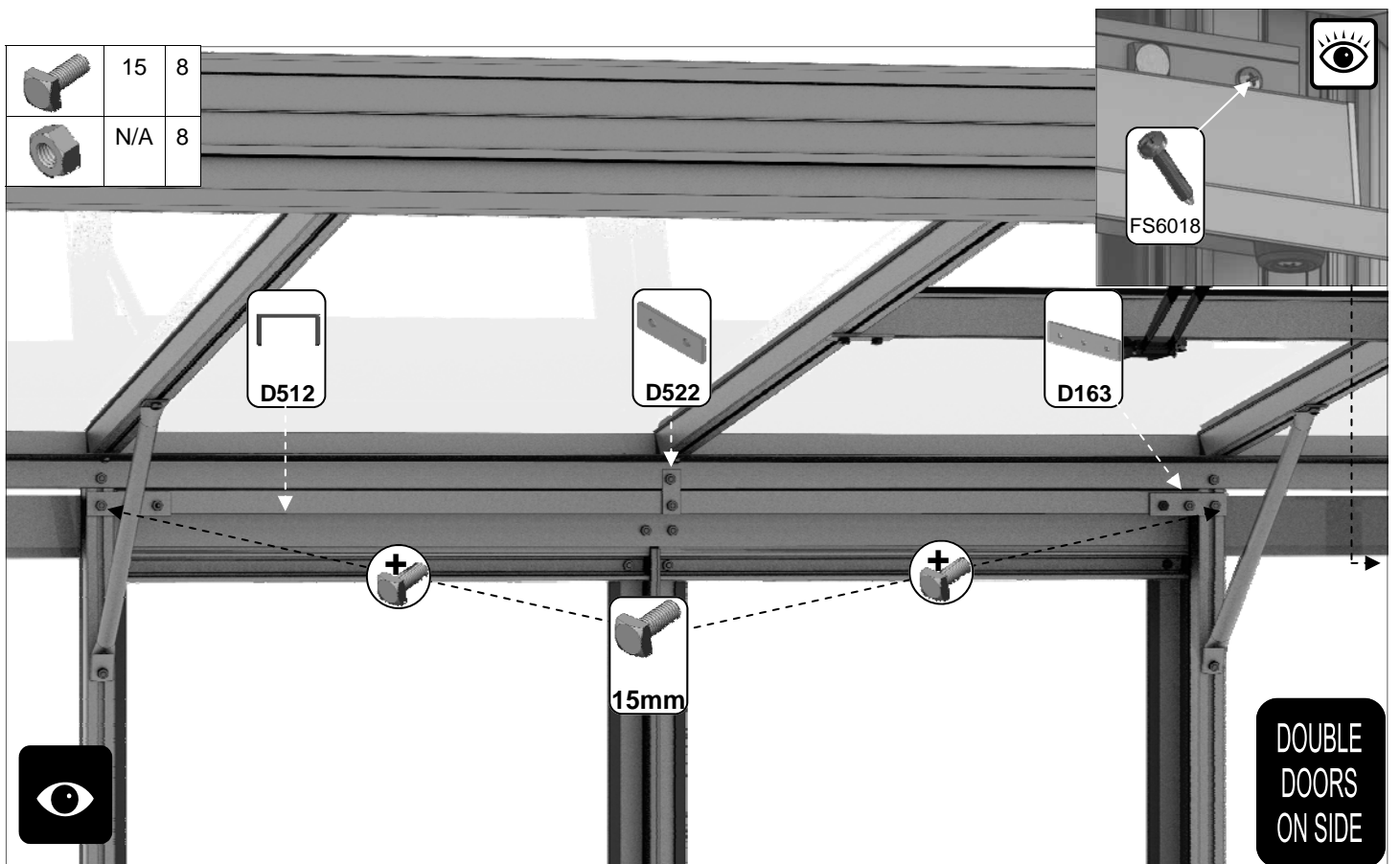
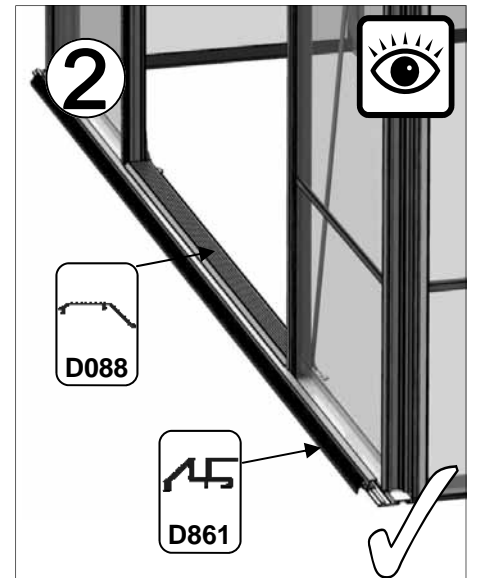
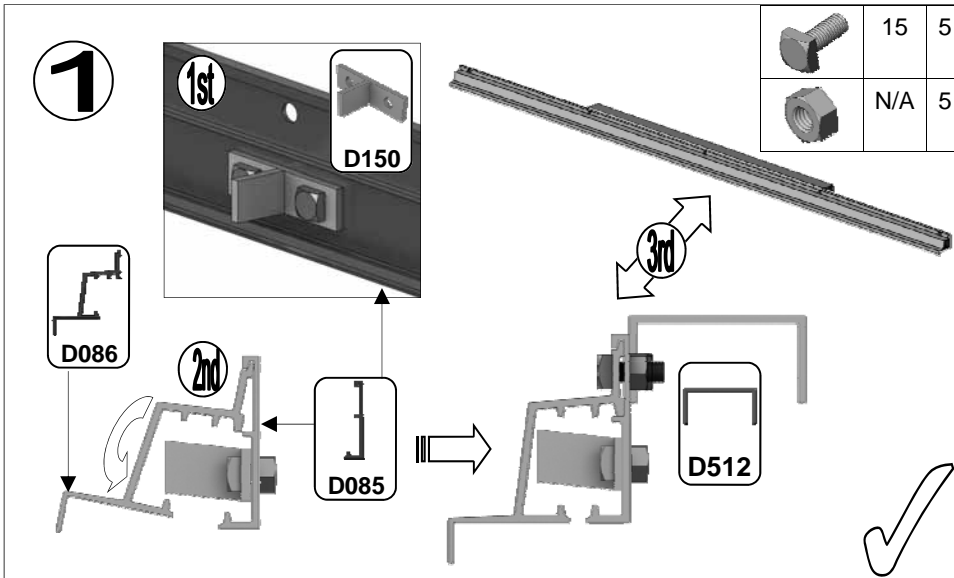
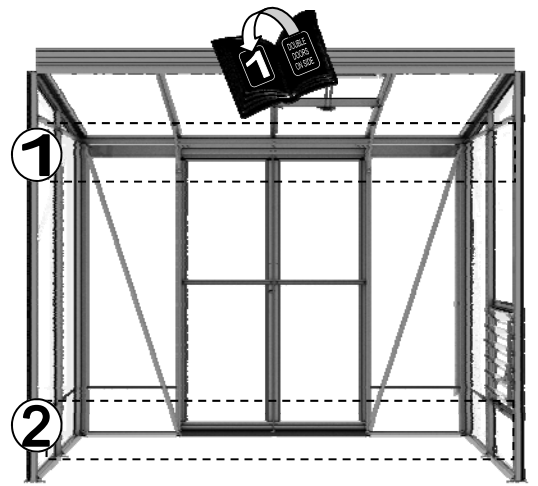

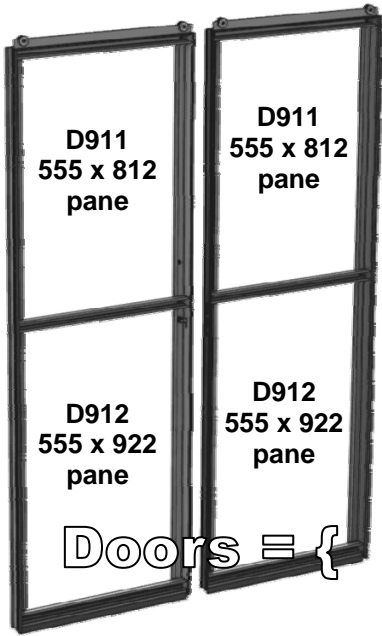

Part No		mm	Q
D094		1824	1
D090 + D347 lock = D301		1824	1
D092 + D156 strike = D303		1824	1
D093		1824	1
D096 + D217 wheel = D307		611	2
D095		611	2
D097		611	2

Part No		mm	Q
D232		905	4
D233		797	4
P053		N/A	2
D225		610	2
D840B		4000	1
D263 PACK x 2		N/A	14
		N/A	14
D261 PACK		N/A	24

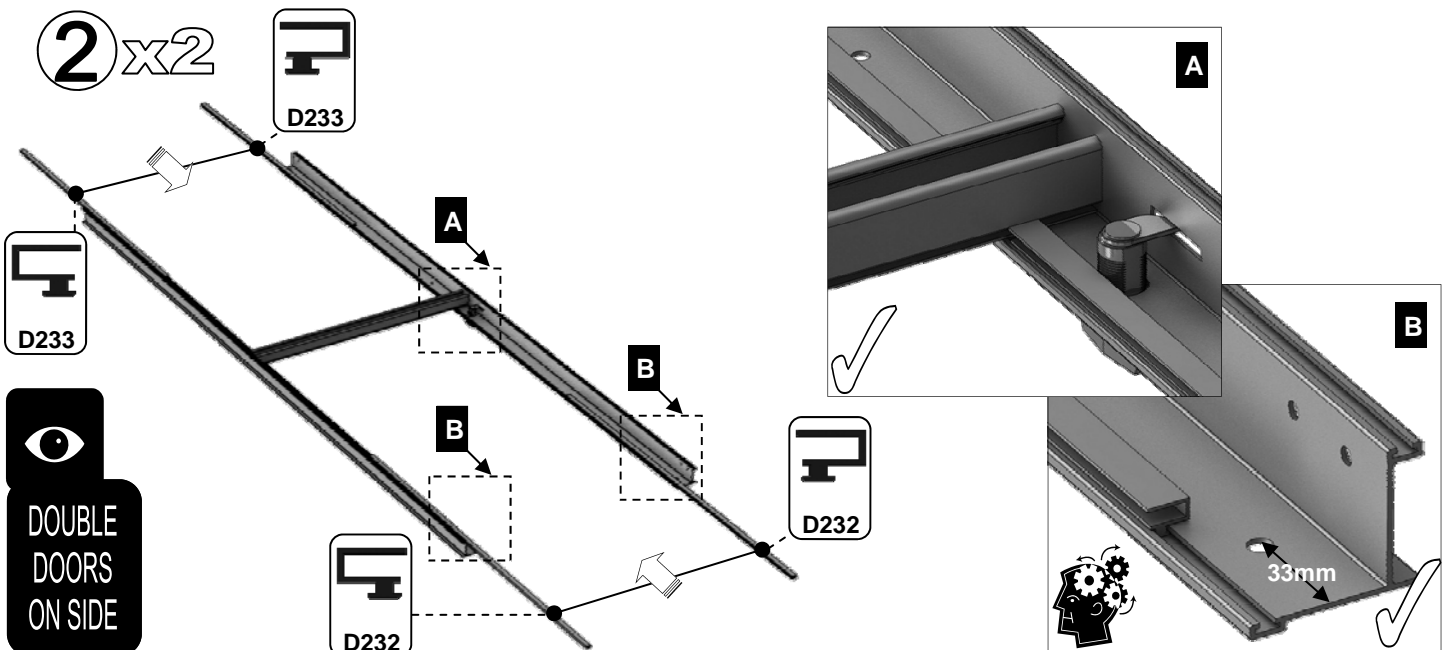
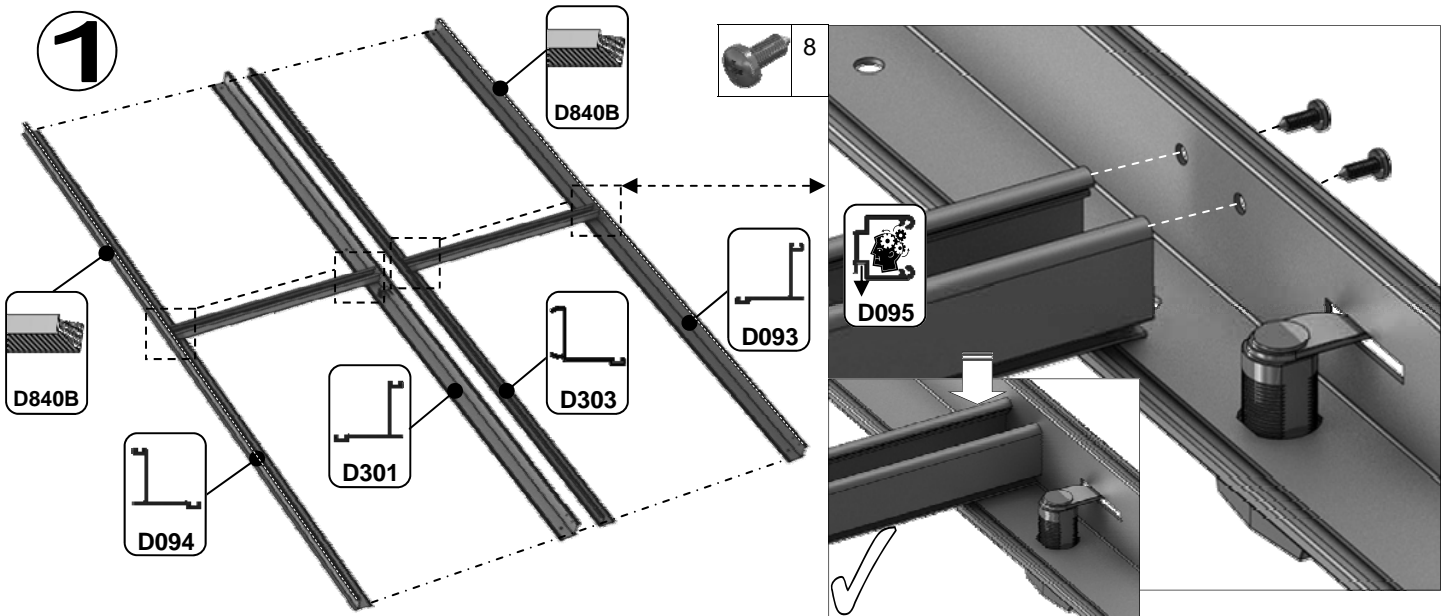

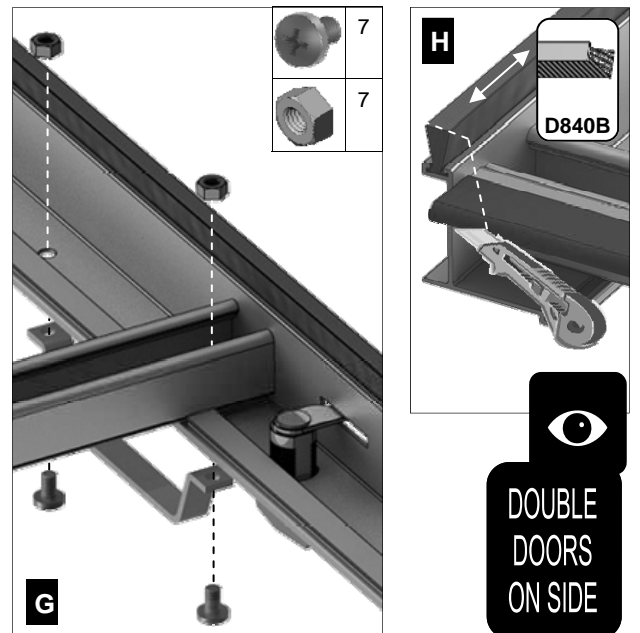
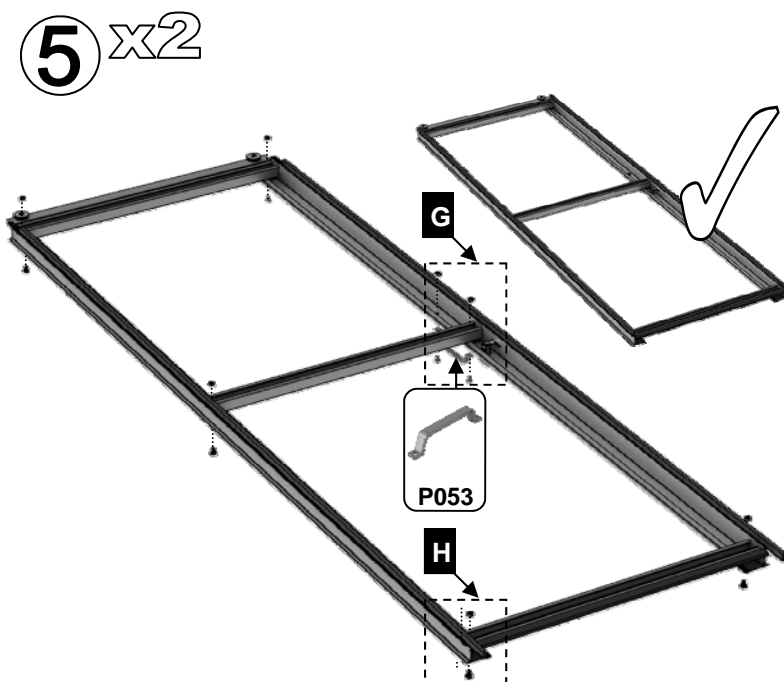
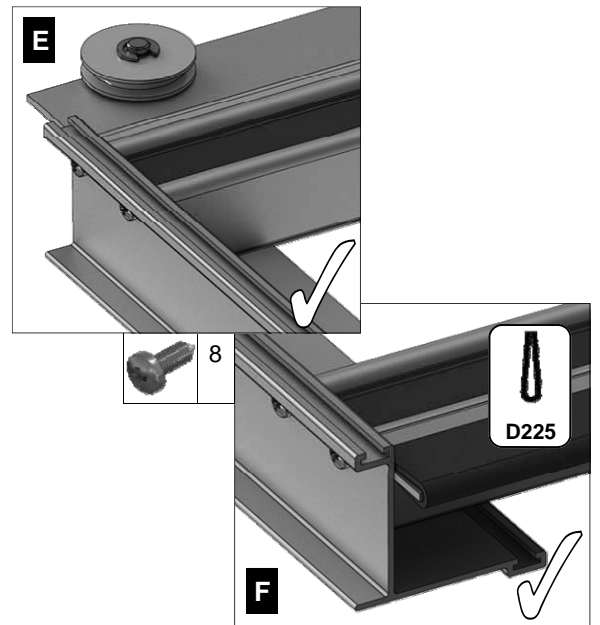
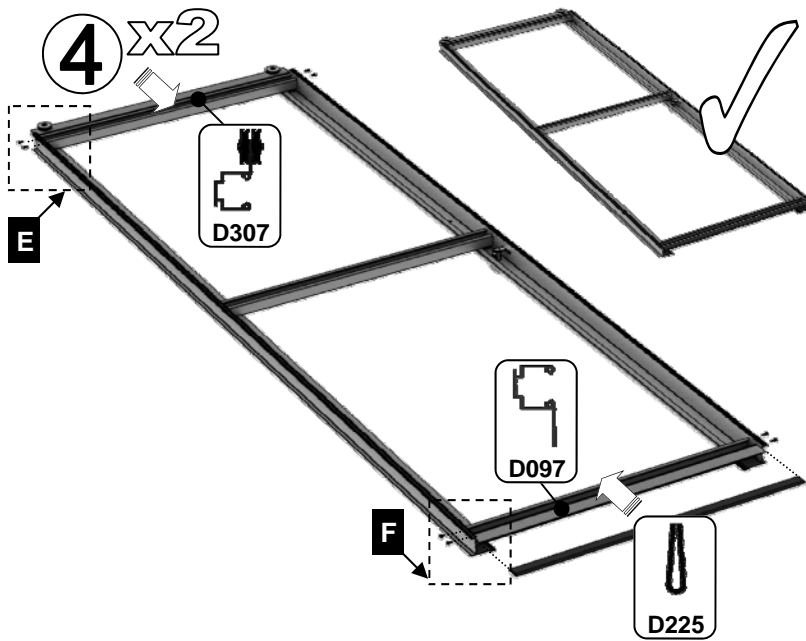
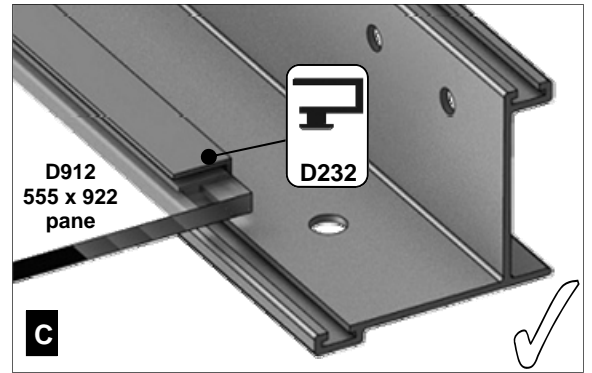
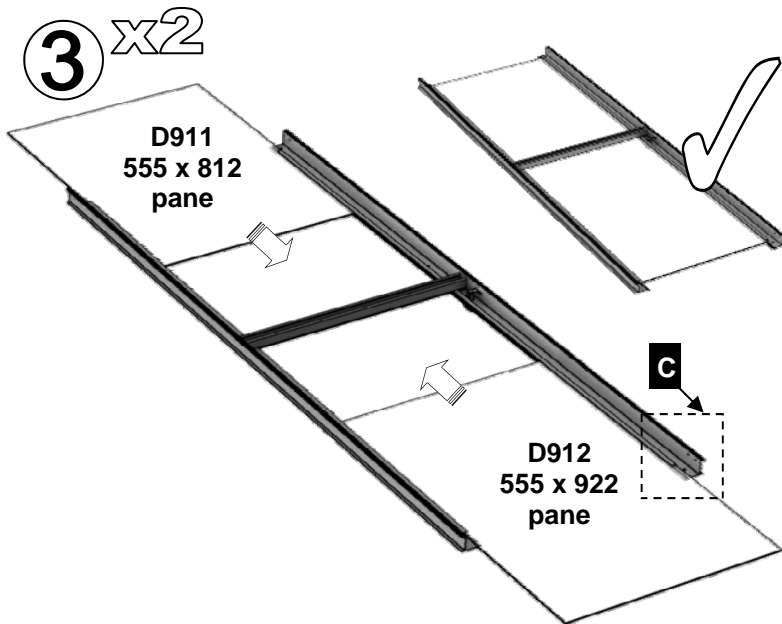

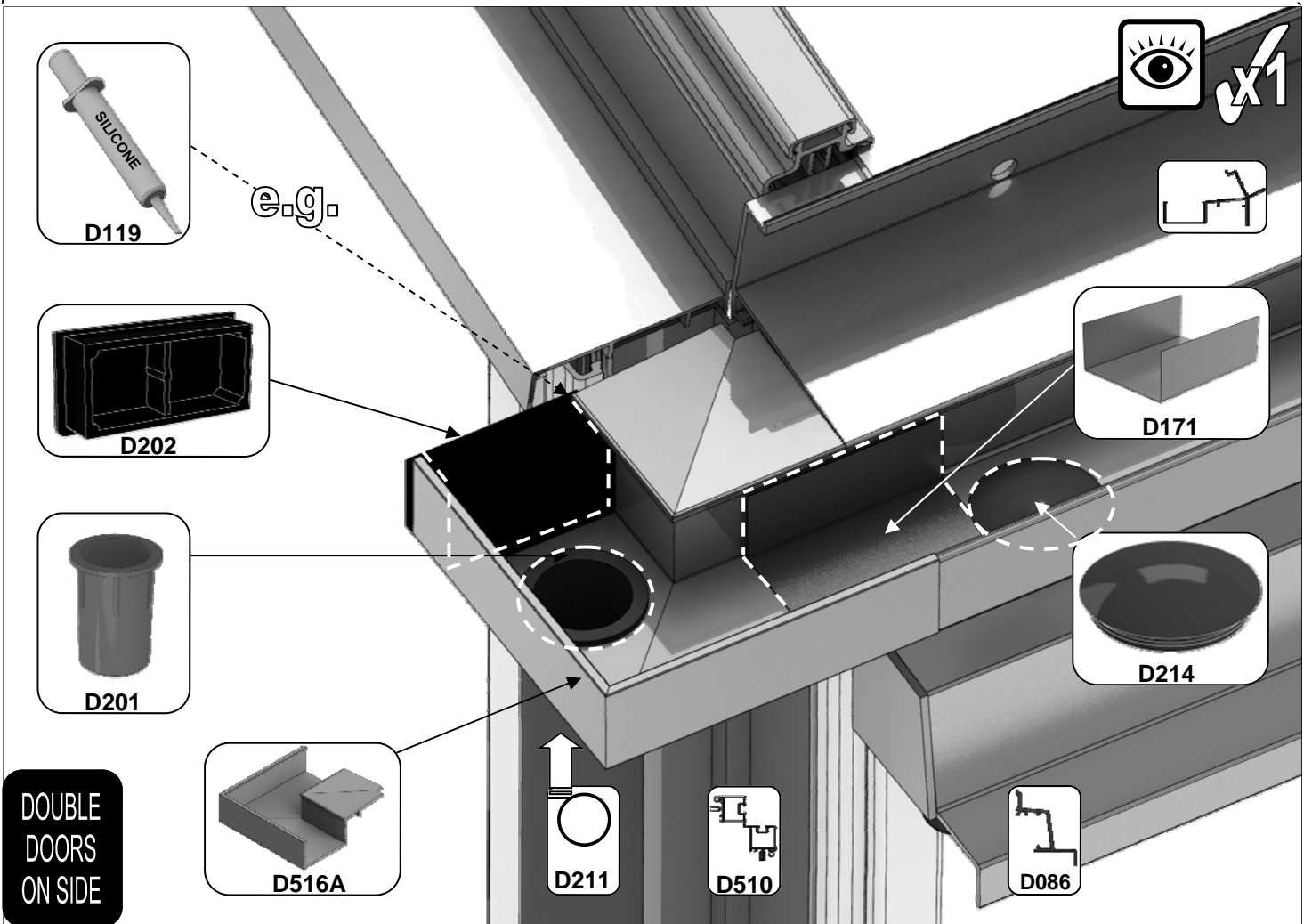
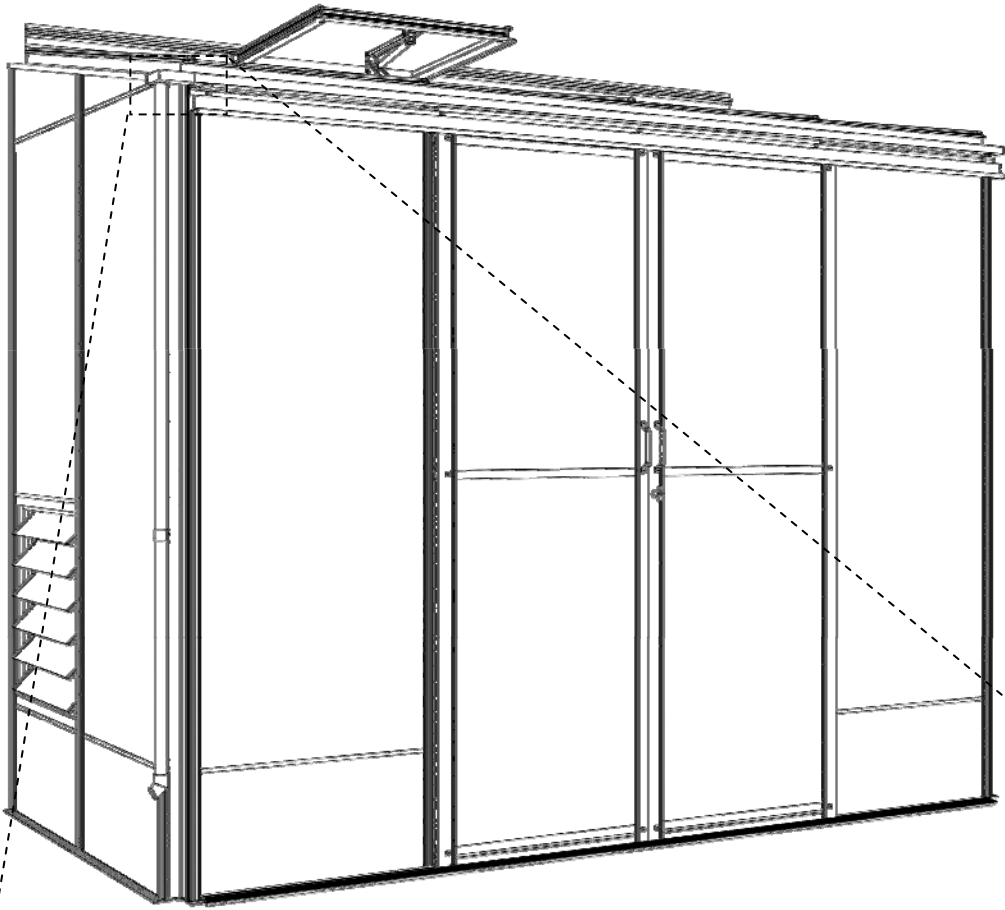

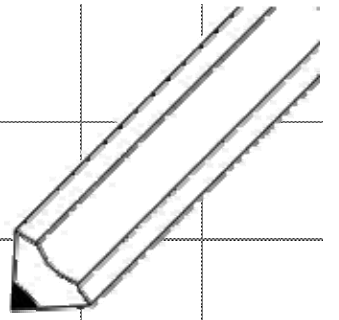

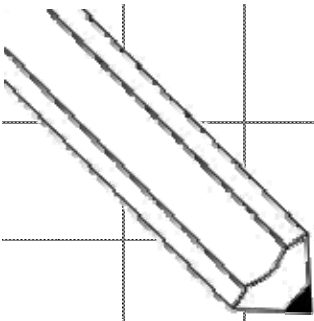

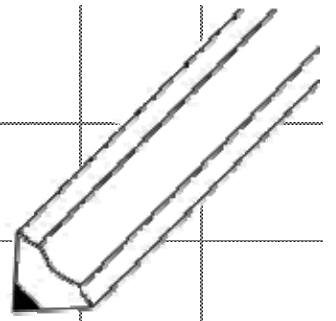

Please be aware that this is a multi-national manual, if you spot any errors or have any constructive comments regarding the manual please email info@greenhousepeople.co.uk and I will make the necessary amendments. Whilst the information contained in this booklet is accurate at the time of publication, changes in the course of Robinsons policy of improvement through development and design might not be indicated. We point out this fact to avoid any infringements of the Trade Descriptions Act and also to advise that Robinsons Greenhouses reserve the right to change specifications and materials without prior notice.

In addition any photographs of completed buildings would be most appreciated to add to our portfolio.

THIS GREENHOUSE BOX WAS PACKED BY:

DATE: _____



www.robinsonsgreenhouses.co.uk

To contact Robinsons Customer Services email us at sales@robinsonsgreenhouses.co.uk or call us on 01782 385 409.

Our address is Robinsons Greenhouses, Unit 19 Blythe Park, Cresswell, Stoke-on-Trent, Staffordshire, ST11 9RD