

8 7 6 5 4 3 2 1

F  
E  
D  
C  
B  
A

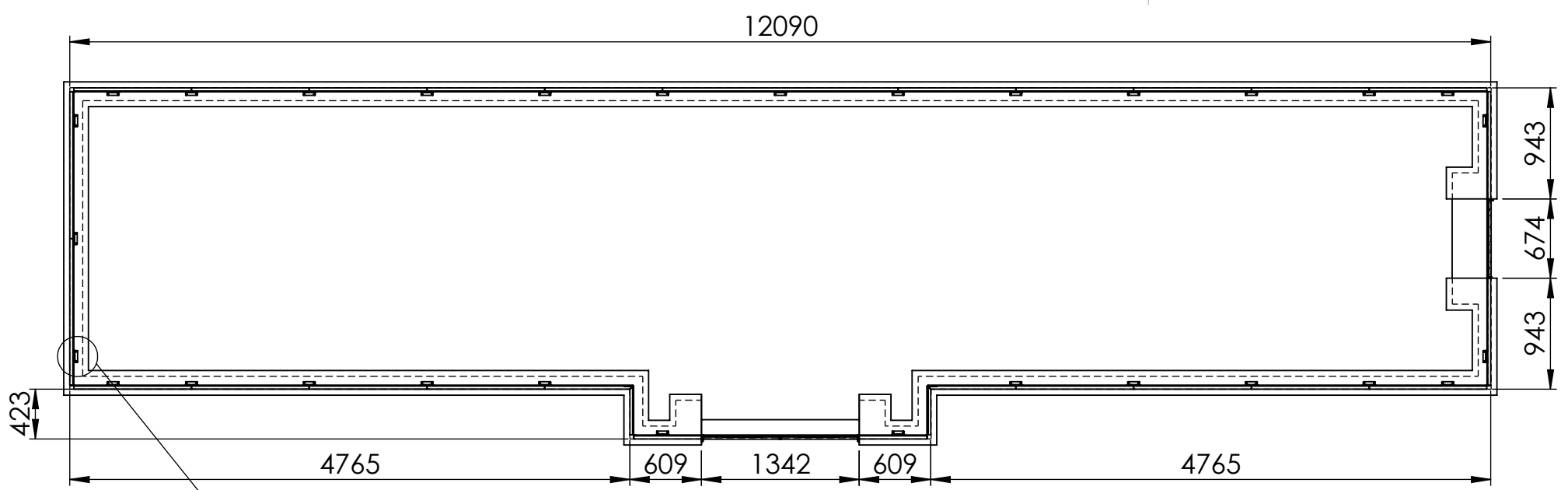

UK	Please note: these dimensions are the outside dimensions of the framework and not the dimensions of the wall. You can determine the size of the wall depending on the brick and cover brick to be used.
DE	Bitte beachten Sie: Diese Maße sind die Außenmaße des Rahmens und nicht die Maße der Wand. Sie können die Größe der Wand in Abhängigkeit von dem zu verwendenden Ziegel und Deckstein bestimmen.
FR	Remarque: ces dimensions sont les dimensions extérieures du cadre et ne sont pas les dimensions du mur. Vous pouvez déterminer la taille du mur en fonction de la brique et le couvre-mur.
NL	Let op: deze maten zijn de buitenmaten van het framework en niet de maten van de muur. Afhankelijk van de te gebruiken steen en deksteen kunt u de maat van de muur bepalen.

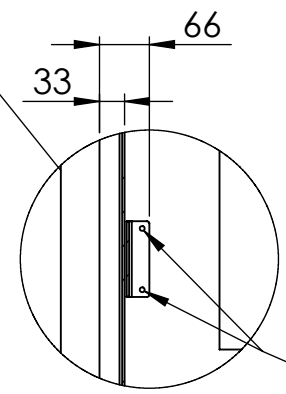
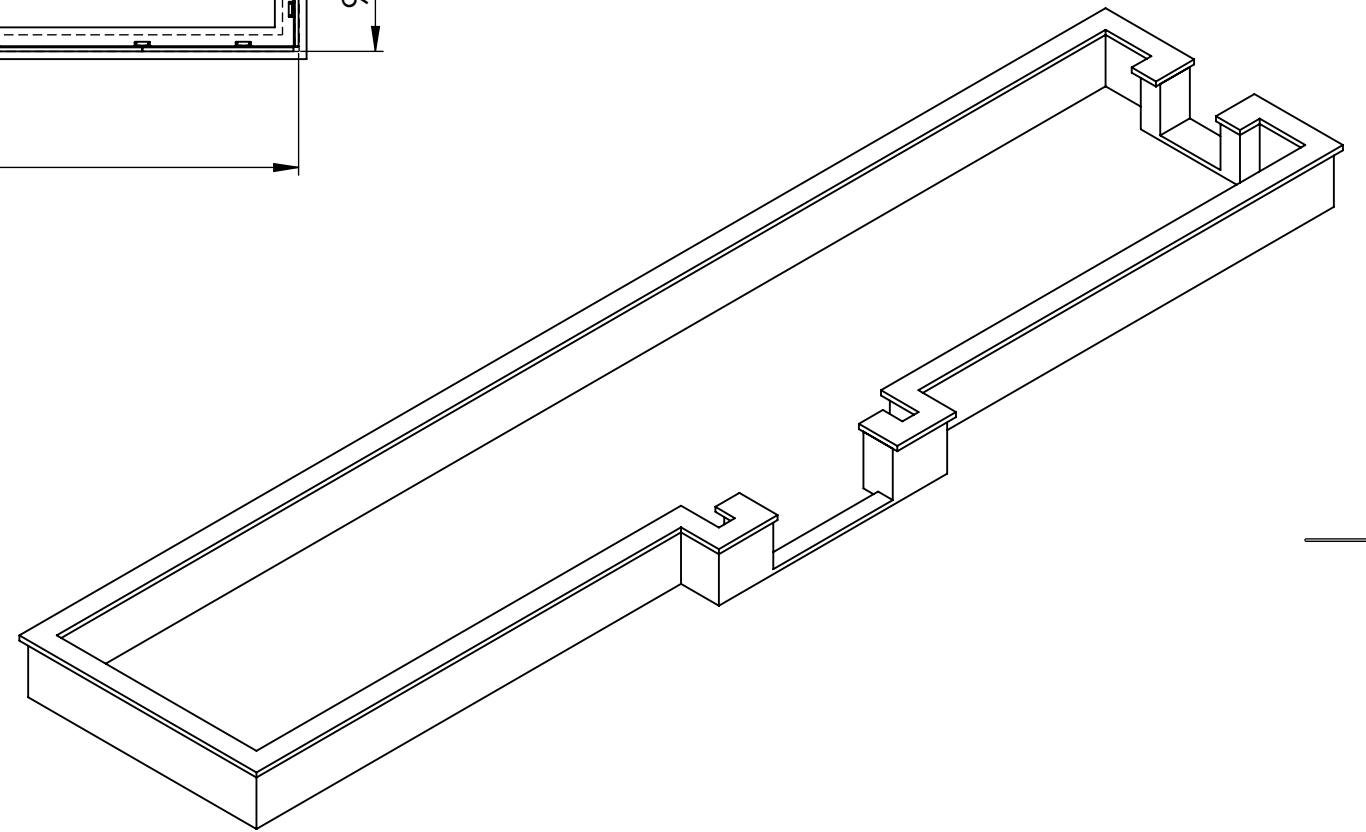

UK: Anchoring hole  
DE: Verankerungsloch  
FR: Trou d'ancrage  
NL: Verankeringsgat

UK: Total height including cover stone  
DE: Gesamthöhe inklusive Deckstein  
FR: Hauteur totale, y compris la couvre-mur  
NL: Totale hoogte inclusief deksteen

UK: Height door opening  
DE: Höhe Türöffnung  
FR: Hauteur d'ouverture de la porte  
NL: Hoogte deuropening

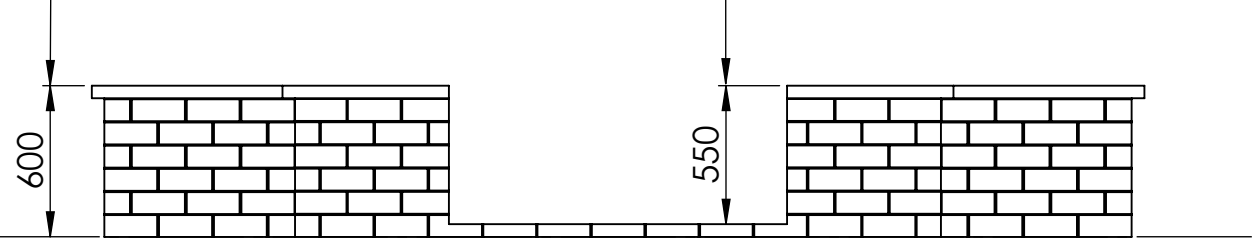

UK: Ground level  
DE: Bodenhöhe  
FR: Niveau du sol  
NL: Maaiveld

8 7 6 5 4 3 2 1

1858 B.V. Pesataweg 67 2153PJ Nieuw-Vennep The Netherlands info@1858.eu	Drawn	Date	Name	Amount	1
	Checked	25-10-2024	Niels van Os	Mass [kg] frame and glass	1477
	Configuration name: Base model with 12 sections and right side door			General tolerance	DIN ISO 2768-c
				Shape / Pos. tol.	NEN ISO 1101
Scale: 1:50	Projection	Name of product:	Drawing number:	Rev: 0	Format:
Units: mm		<b>Vogelensang</b>	<b>22.221-05-03</b>	Sheet 1 of 1	<b>A3</b>

F  
E  
D  
C  
B  
A