

Victorian 'ROEDEAN' 11 Dwarf Assembly Instructions

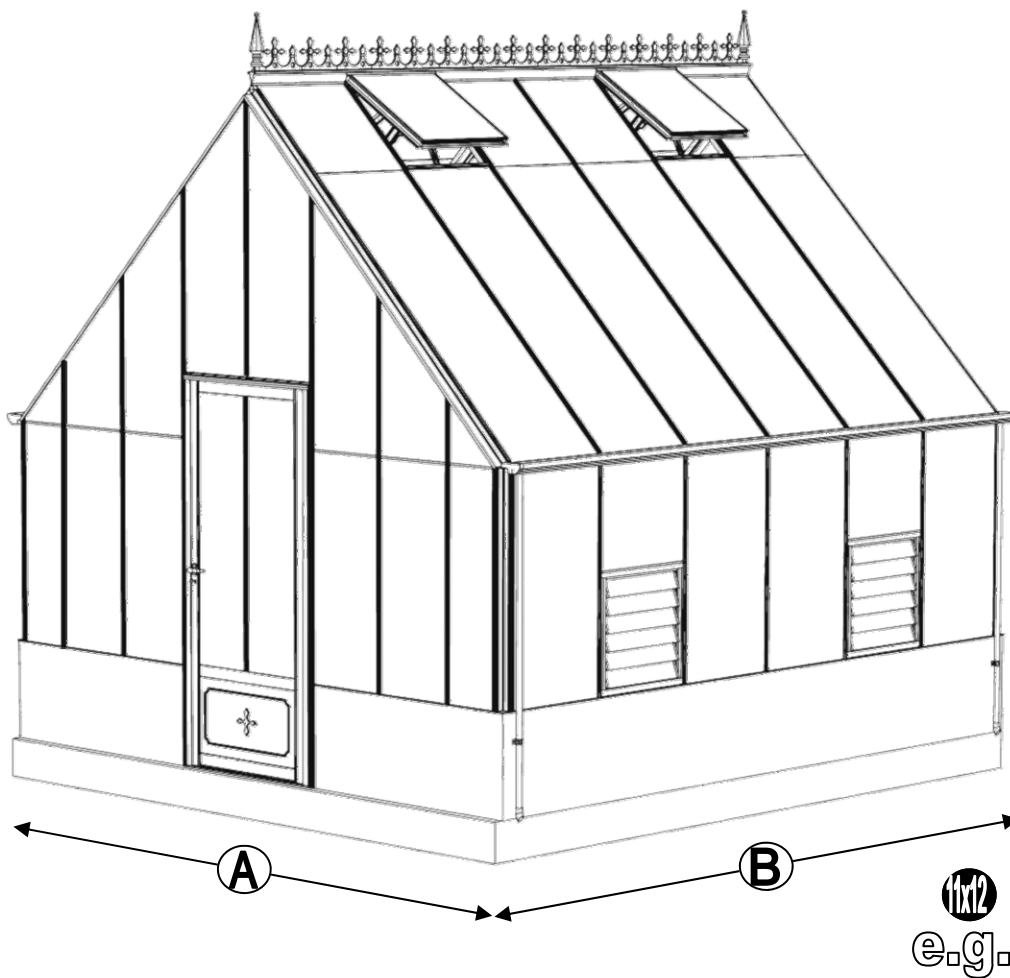

NOMINAL SIZE	A (mm)	B (mm)
11 X 6	3532	1990
11 X 8		2610
11 X 10		3230
11 X 12		3850

GB Thank you for purchasing your new Robinsons greenhouse. We recommend you familiarise yourself with the instructions and read all safety information before you commence assembly. This instruction manual is also available online at www.robinsongreenhouses.co.uk in our technical help section should you need to reprint it. Should you require any additional advice you can always call us on 01782 385409.

These instructions are divided into sections highlighted by a white number/letter on a black background at the bottom corner of most pages (see opposite page for details); **part lists**, **B**-base, **P**-preparation, **1**-sides, **2**-front gable, **3**-rear, **4**-joining the four sides together, **5**-louvre, **6**-roof, **7**-vent, **8**-glazing, **9**-vent attachment, **10**-door attachment, **11** anchoring down, **12** finishing touches, **13** optional shelf, **14** optional staging. If you need to contact us for assistance please refer to the relevant section/s. If your building is longer than 12', i.e. has an extension then please also refer the separate extension manual.

Safety Warning

- Glass and aluminium can potentially cause injury. Please ensure you wear protective goggles, gloves, headgear and suitable footwear when assembling and glazing the building.
- Please remember that glass is fragile and should be handled with extreme care. Always clear up and dispose of any breakages immediately.
- Do not assemble the greenhouse in high winds.
- For safety reasons and ease of assembly, we recommend that this greenhouse is assembled by a minimum of two people.
- Please clear all lying snow from the greenhouse roof as it can cause the roof to buckle or collapse.

Site Preparation

- When selecting a site for your greenhouse, it is vital that you choose as flat and level an area as possible.
- A concrete or slabbed base will provide the most solid foundation for your greenhouse.
- **IMPORTANT:** Do **not** fix your building down until the building is fully assembled, including glazing.
- Avoid placing your greenhouse under trees or in other vulnerable locations.
- To minimise the risk of wind damage, try to select as sheltered a site as possible, e.g. beside a hedgerow or garden fence.

Additional Considerations

- Please bear in mind that assembling your greenhouse can be time consuming. You may need to spread the construction over two or more days. We recommend that you avoid leaving the building partially glazed. If you ever have to leave your greenhouse half assembled and not anchored down, weigh it down with slabs or bags of sand to stop the wind moving it.
- You will find it helpful to prepare a large, clean and clear area in which to work in. A garage floor or flat lawn area is ideal.
- If you have arranged for someone to install your greenhouse for you, please check that all components are included. Some parts are numbered and can be identified by a stamped or hand written number (without the 'D'). Alternatively, the components can be identified by their distinctive profiles, lengths and quantities detailed in the parts list (see next page).
- Anchoring down your greenhouse should be the final stage of construction (including glazing).
- Once installed your greenhouse requires little maintenance, but to maintain the smooth running of your door(s) WD40 or similar can be applied to the door pivot pins / lock etc...

Guarantee

- Your new Robinsons greenhouse is guaranteed for 10 years against faulty manufacture of the framework. This does not include glazing, moving parts, accidental damage or wind damage.

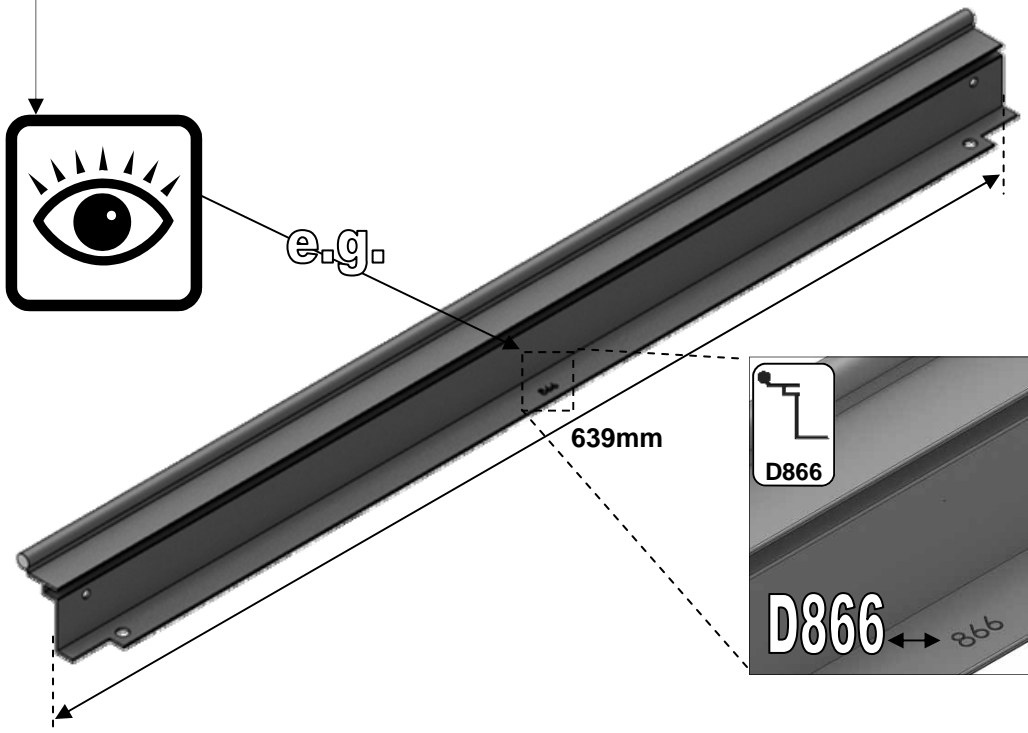









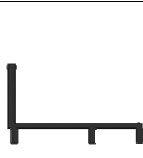
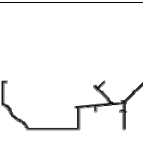





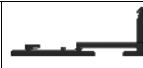

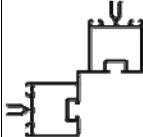
KEY SYMBOL	KEY DESCRIPTION
	EXTERNAL VIEW
	INTERNAL VIEW
	THINK
	THIS SECTION RELATES TO ANOTHER (e.g. 1 to 5)
	CORRECT
	DO NOT FIX DOWN!
	TWIST TO LOCK
	TIGHTEN
	PUSH AND HOLD
	CUT TO LENGTH



SECTION No	TITLE	ASSEMBLY SYNOPSIS: IMPORTANT INFORMATION / CONSIDERATIONS
B P 1 2 3 4 5 6 7a 7b 8 9 10 11 12 13 14	PARTS LIST	Most components should have a 'D' code punched into their metal surface. Identify and separate all like for like components prior to assembly. The 'parts list' also separates parts into the various sections 1 - 12 shown below. Parts can also be identified by their profile pictures and stated lengths etc..
	BASE	Base dimensions and recommendations. Ensure that your base is level as this will make assembly of the building, especially the glazing of the roof much more straight forward. Please be aware that the hinge door on your greenhouse opens inwards, make sure that there will be no interference between the door and the foundations.
	PREPARATION	Tools required. IMPORTANT: Use WD40 or similar in the glazing bar channels and insert the black glazing rubber prior to frame assembly.
	SIDES	Take the side glazing bars 'D609' with the rubber inserted and the diagonal braces 'D604', use 10mm bolts to join them to the gutter and 15mm bolts to the cills (note how the head of the bolt slides into each glazing bar during construction). Please also remember to slide in your 22mm bolts for attaching the decorative eave spandrels 'DV100' in section 5.
	FRONT	Again ensuring that the gable framework is rubbered-up follow the diagrams to assemble each end of the building. Make sure that you have inserted the extra bolts utilised in sections 4 and 5. On the roof and side corner bars not every rubber channel will require rubber unless it is to be utilised in a partition (see separate manual and section P).
	REAR	
	JOINING THE FOUR SIDES	Take the two sides (1) and both gables (2 & 3) and join them together on your base. It is a good idea to tie some ladders to the sides to support them if you do not have anyone to hold them for you.
	LOUVRE	They attach to the building during the glazing process (8) like a piece of glass with a black separator above them. If you are fitting an optional auto-louvre then you need to carefully drill (3mm bit) out the rivets which mount the handle to the frame. You can then either utilise those holes or create more to mount the unit.
	ROOF	Attach the ridge and then the rubbered-up roof bars ensuring that they are fully butted up to the ridge and down onto the gutter. Attach your cresting before you glaze the building to give yourself more room to work. Utilise the 22mm bolts slid into the side (section 1) and roof bars to attach your DV100 and DV101 spandrels. On longer models you may need to carefully prop up the roof and tie the sides together to keep the ridge and gutters straight (i.e. not sagging or bowed) until the building is fully glazed.
	VENT	Once the vent is glazed add silicone to the vent sides and top. Stand the vent/s on their hinge (vent top) and then leave the silicone to set.
	VENT SLAM	The slam bar 'D079' can be moved up and down between the roof glazing bars so that it can be butted down onto the pane of glass beneath, the autovent will be attached to it later on (9).
	GLAZING	Layout the bar cappings and covers around the building like a sundial checking that all is present and correct. You can also place the roof cappings in the gutters so they are closer to hand. The glass in the ends has to bevel on the black separator strip, this bevelling action allows the glass to tuck underneath the roof corner canopy. Use the capping and the self tapping screws to then hold the glass in place. The covers then enclose the screw heads giving a neat finish. It is a good idea to glaze two roof sections first to ensure the building is square followed by two side sections to ensure the building isn't leaning. IMPORTANT: On the roof sections please make sure that you place a screw around 25mm / 1" from the bottom of each capping strip (create a hole in the plastic if required) and that the screws are nice and tight to avoid any glass slippage.
	VENT ATTACHMENT	Take the assembled vent and slide the vent hinge 'D866' into the end of the ridge allowing the vent the pivot open and closed. Vent stops go either side of the vent to stop any lateral movement (so insert stop / vent / stop). Attach the Bay-liss XL autovents.
	DOOR ATTACHMENT	Your door comes pre-constructed and locked minus the handles and their pivot pin but now it needs to be mounted to the front end of your building. Utilise the 'DV522' plates and twist in crop headed bolts to join the door and its frame to the building (pinch the door frame against your long front verticals whilst tightening your 'DV522' plates to ensure that there is no gap). If you are struggling to eradicate the gap between the door frame and verticals then some silicone can be carefully applied to the area to create a vertical seal. Be careful not to lock yourself in the building and to avoid damage do not open the door until it is attached to the front gable. Getting the door to swing perfectly without dropping or rubbing on the ground may require some small but vital adjustments. You may also need to insert a packer underneath the door frame hinge to increase ground clearance. Part 'DV275' canopies the door frame top hiding the clearance space at the top of the door. The door can only be made to swing inwards. IMPORTANT: Please do NOT let the door slam open or closed as it is likely to cause damage to the door and the frame. Please twist the handle to open and close. Please also be aware that your door KEYS (3 provided) are unique to the building so they should not be stored together.
ANCHORING DOWN	Now that the greenhouse is finished and the door and vent/s are operating without interference then you need to anchor the building down using 2" rawl plugs and screws. Use a 7mm masonry bit in a hammer drill to create the holes.	
FINISHING TOUCHES	Now that the main body of the structure is complete you can add; downpipe fittings, eave bungs, gutter stop ends. It is also important to carefully apply some silicone to the internal eaves corners and external and internal ridge corners to minimise the chance of water entering the structure.	
OPTIONAL SHELVING	Robinsons integral cantilever staging and shelving attaches to the inside of the greenhouse frame using either square head bolts (insert four into each side glazing bar 'D609' during construction of the sides (1)) or rectangular 'crop head' bolts which can be fitted retrospectively (both sets of bolts accompany the shelving/staging). This system allows the height of either the staging or the shelf to be set at an operator specific height. Commonly the staging brackets are set 900mm from the cills though you can alter this to suit the end user/s. The aluminium shelf / staging slats come in two lengths; (4'):1240mm 'D2002' and (6'):1860mm 'D2003'. These slats can combine to create any length of staging required, i.e. 4'+6' = 10' etc...	
OPTIONAL STAGING		

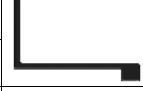

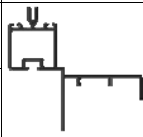



Section Ref	Part No.	Section	Size (mm)	11 6	11 8	11 10	11 12
-------------	----------	---------	-----------	------	------	-------	-------

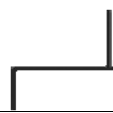

1	D043		1894	2			
	D021		2514		2		
	D022		3134			2	
	D023		3754				2
	DV213		1897	2			
	DV210		2517		2		
	DV211		3137			2	
	DV212		3757				2
	D604		1316	4			
	D609		1160	4	6	8	10
	RUBBER		1000 (1m)	10	14	19	24
	D174		N/A	4	4	8	8

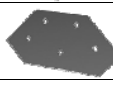

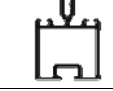

2 + 3	DV232		3548		1		
	DV303L		1319		1		
	DV303R				1		
	D608		1160		4		
	DV066L		1505		2		
	DV066R				2		
	DV239L		2960		1		
	DV239R				1		
	DV310L		1972		2		
	DV310R				2		
	DV312L		2438		1		
	DV312R				1		
	DV259		2879		1		
	DV271L		1249		1		
	DV271R				1		
	DV274		3402		1		
	DV307		1350		4		
	DV252L		2451		2		
	DV252R				2		
	DV264		1398		1		

11' Dwarf Victorian

Section Ref	Part No.	Section	Size (mm)	11 6	11 8	11 10	11 12
-------------	----------	---------	-----------	------	------	-------	-------



2 + 3	DV275		904		1		
	DV104		N/A		4		
	DV105		N/A		2		
	D163		90		2		
	RUBBER		1000 (1m)		71		
	D174		N/A		11		

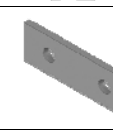

5	DV204		1897	1			
	DV201		2517		1		
	DV202		3137			1	
	DV203		3757				1
	DV255		2450	4	6	8	10
RUBBER		1000 (1m)	20	30	40	50	

6	D866		639	2	2	4	4
	D863L		613	2	2	4	4
	D863R		613	2	2	4	4
	D862		593	2	2	4	4
	D079 PLUS FLUFF		590	2	2	4	4
	D114		N/A	4	4	8	8
	D220 PLUS FS6060 SCREW		N/A	4	4	8	8
	D205		N/A	4	4	8	8

Section Ref	Part No.	Section	Size (mm)	11 6	11 8	11 10	11 12
-------------	----------	---------	-----------	------	------	-------	-------





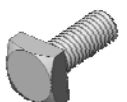
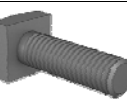
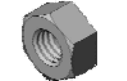

Section Ref	Part No.	Section	Size (mm)	11 6	11 8	11 10	11 12
-------------	----------	---------	-----------	------	------	-------	-------

8	1	D618		1144	4	6	8	10
	2/3	DV403L/R		1505	2 + 2			
	10	DV479		1384	1			
	2/3	DV610L/R		1972	2 + 2			
	3	DV612L/R		2438	1 + 1			
	2	DV639L/R		2960	1 + 1			
	5	DV655		1880	4	6	8	10
	3	DV659		2879	1			
	2 / 10	DV664		1373	1			
	5	D870		601	4	6	8	10
	2/3	D610		1160	4			
	1	D620		1144	4			
	5	D871		601	4			
	5	DV652		1871	4			
	2/3	D614		1162	4			
1	D619	1144		8	10	12	14	
10	DV480	1384		1				
2/3	DV611L/R	1972		2 + 2				
3	DV613L/R	2438		1 + 1				
2/3	DV615L/R	1505		2 + 2				
2	DV640L/R	2960		1 + 1				
5	DV658	2481		8	10	12	14	
3	DV665	2879		1				
2 / 10	DV670	1373		1				

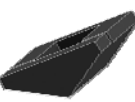
12	DV219		N/A	2			
	DV218		N/A	2			

MAIN FRAME QUANTITIES VENTS / DOORS etc SEPERATE			84	90	96	102
		SYBOLM6x11 10mm				
		SYBOLM6x15 15mm	31	33	35	37
		SYBOLM6x22 22mm	24	36	48	60
		SYNUTM6 M6 NUT	139	159	179	199

10	D522		N/A	10
-----------	------	---	-----	----

12	D119		N/A	1
	DV120		N/A	4
	D841		N/A	2
	D211		1625	2
	D207		N/A	2
	D214		N/A	2
	D201		N/A	2
	D208		N/A	2



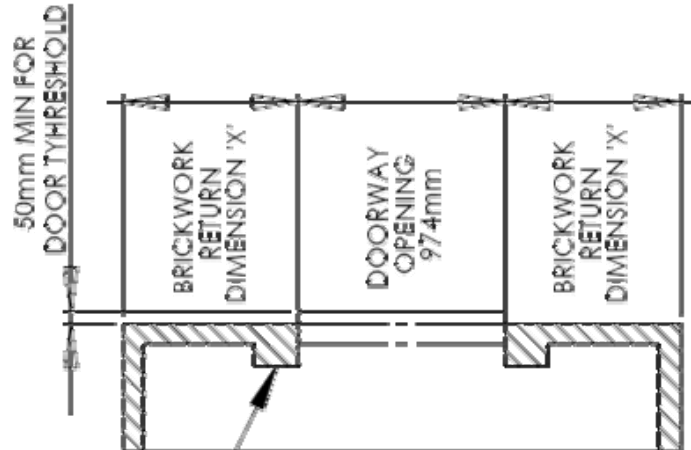
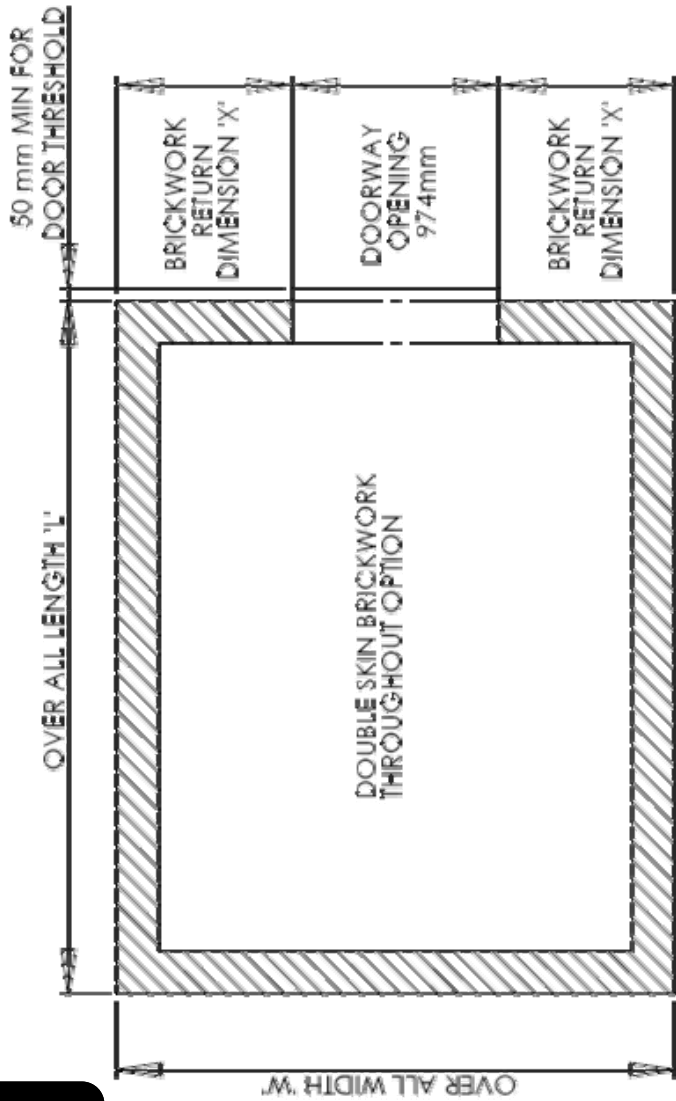

GREENHOUSE TYPE	OVER ALL WIDTH 'W'	OVER ALL BRICKWORK RETURN DIMENSION 'X'
RUGBY (6 WIDTH)	1968mm	497mm
RUSHMOOR (8 WIDTH)	2598mm	812mm
RODEAN (11 WIDTH)	3532mm	1279mm

OVER ALL LENGTH 'L' = BASIC GREENHOUSE LENGTH + EXTENSION LENGTH IF REQUIRED		
BASIC GREENHOUSE LENGTH	GREENHOUSE EXTENSION	EX. LENGTH
6 LONG	6 EXT LONG	1860mm
8 LONG	8 EXT LONG	2480mm
10 LONG	10 EXT LONG	3100mm
12 LONG	12 EXT LONG	3720mm

GUIDANCE NOTE FOR ROBINSONS DWARF WALL GREENHOUSES, FOOTINGS
 CONCRETE STRIP FOOTINGS SHOULD BE A MINIMUM OF 400mm WIDE X 200mm DEEP. IF THE SITE IS ON MADE UP GROUND IT IS IMPORTANT THAT THE FOOTINGS ARE CUT INTO THE COMPACTED GROUND BELOW. WHERE THE GROUND IS LIABLE TO MOVEMENT SUCH AS HEAVY CLAY OR LOOSE SANDY SOIL REINFORCING SHOULD BE ADDED TO THE CONCRETE FOOTINGS.

WALLS
 IT IS MOST IMPORTANT THAT THE BRICKWORK IS IN ACCORDANCE WITH THE 'mm' DIMENSIONS PROVIDED AND IS SQUARE, LEVEL AND UPRIGHT, THE DIAGONAL MEASUREMENTS SHOULD BE EQUAL.

WALLS CAN BE EITHER DOUBLE OR SINGLE SKIN.
 THE TOP COURSE OF BRICKS SHOULD BE LAID FROG DOWN. IF ENGINEERING BRICKS ARE USED FOR THE TOP COURSE PLEASE ENSURE THEY ARE SOLID NOT CELLULAR (WITH HOLES THROUGH THEM) OR FIXING DOWN OF THE GREENHOUSE WILL BE A PROBLEM. BRICKS SHOULD BE A GOOD QUALITY STOCK BRICK, SAND FACED FLETTON TYPE BRICKS ARE NOT SUITABLE.

GABLE DOOR OPENING
 THE DOOR THRESHOLD REQUIRES BRICK WORK ACROSS THE OPENING WHICH SHOULD BE LEVEL WITH THE FINISHED FLOOR LEVEL (F.F.L) OF THE GREENHOUSE. THE OPENING FOR THE DOORWAY AND THE HEIGHT TO THE TOP OF THE WALL FROM THE THRESHOLD LEVEL REQUIRES THE HIGHEST ACCURACY AND ARE MOST IMPORTANT SO THAT THE DOOR FITS THE APERTURE CORRECTLY. PLEASE ALSO BE AWARE THAT THE DOOR OPENS INWARDS AND THEREFORE THE FOUNDATIONS NEED TO AVOID ANY DOOR INTERFERENCE. IT IS ADVISABLE TO MAKE A WOODEN TEMPLATE TO CHECK THE DOOR APERTURE DIMENSIONS.

IF SINGLE SKIN WALLS ARE USED THEN PIERS SHOULD BE FORMED AT THE DOOR OPENING.

IN ORDER TO SUPPORT THE OUTER EDGE OF THE DOOR THRESHOLD THERE MUST BE A PROJECTION OF BRICKWORK / CONCRETE IN FRONT OF THE DOOR END WALL WITH A MINIMUM WIDTH OF 50mm. THIS NEEDS TO BE LEVEL WITH THE DOOR THRESHOLD OPENING.

Property of 'Robinsons Greenhouses' © 2015

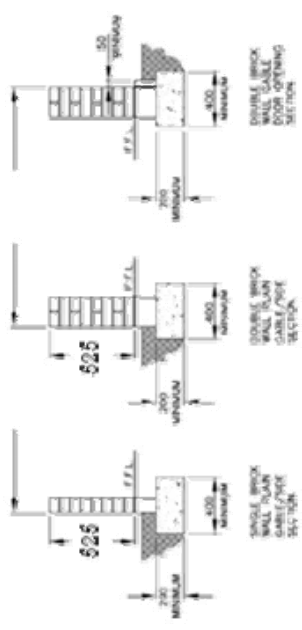

TITLE: ROBINSONS VICTORIAN DWARF WALL RANGE
 THIS PLAN APPLIES TO GREENHOUSE WITH DOOR AT ONE END ONLY.

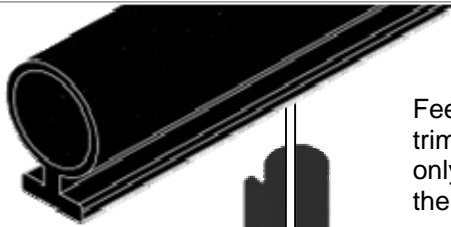

Feed glazing rubber into each glazing bar and trim to length. Notice that some channels are only used on a partition. Applying a lubricant to the aluminium channels will speed up insertion.



e.g.

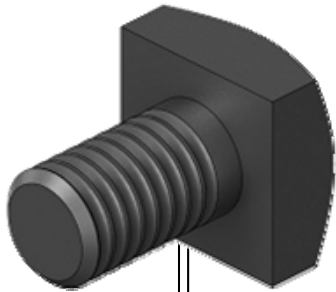
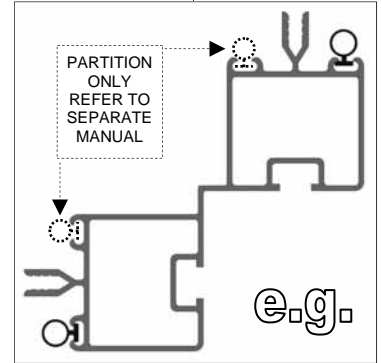
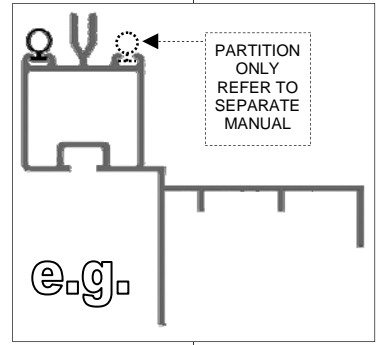
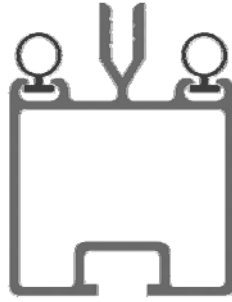

The frame is assembled by feeding square headed bolts, either 10mm or 15mm in length into the slots on glazing bars and then locating those bolts through holes in purlings and cills, etc... Twist in (rectangular) crop headed bolts are also used towards the end of construction to attach components to the frame when the glazing bar slots are no longer exposed at the ends.



e.g.

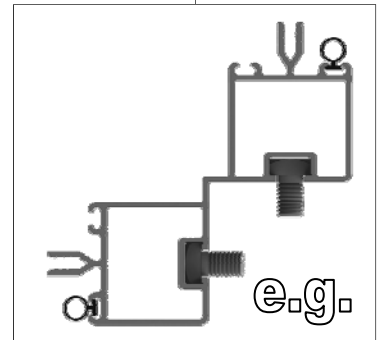
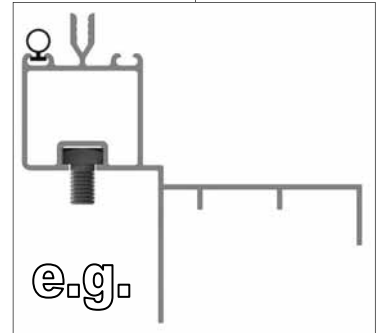
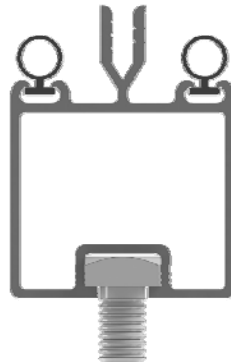

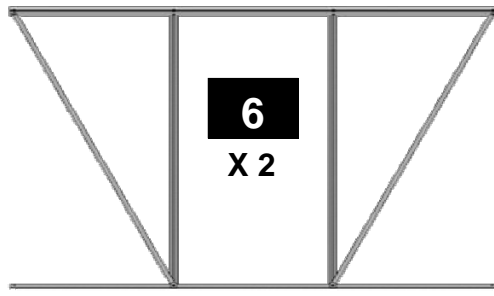
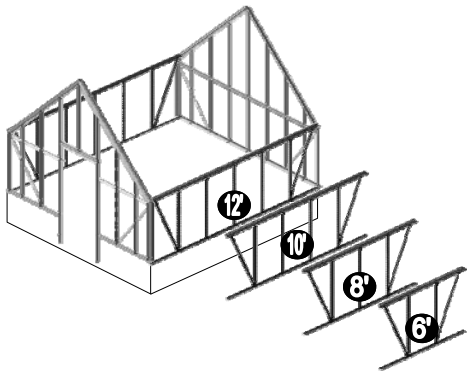

6
X 2

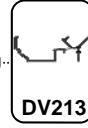

DV213

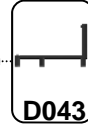

D043

6 X 2 DWARF		
Part No	mm	Quantity
DV213	1897	2
D043	1894	2
D609	1160	4
D604	1316	4
D174		4
SYBOLM6X11		4
SYBOLM6X15		8
SYBOLM6X22		8
SYNUTM6		12
Rubber	1000	10

e.g. ①

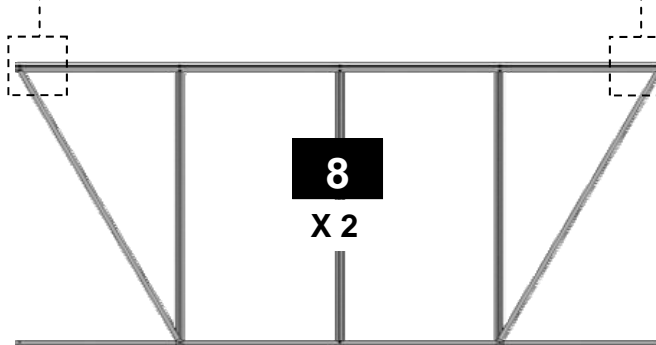

8
X 2

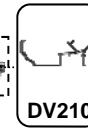

DV210



D021

8 X 2 DWARF		
Part No	mm	Quantity
DV210	2517	2
D021	2514	2
D609	1160	6
D604	1316	4
D174		4
SYBOLM6X11		6
SYBOLM6X15		10
SYBOLM6X22		12
SYNUTM6		16
Rubber	1000	14

e.g. ②

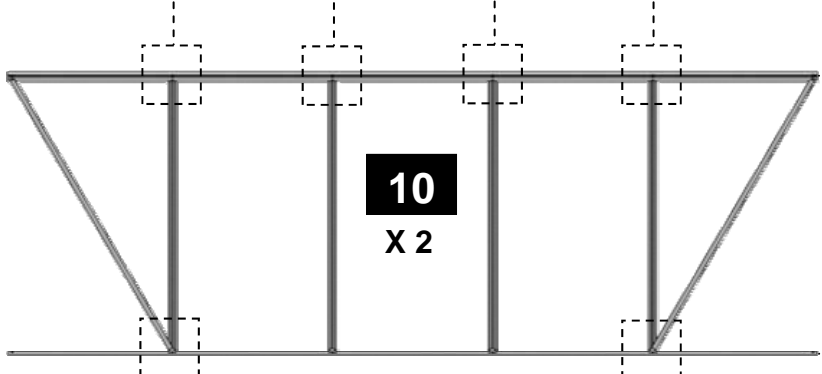

10
X 2

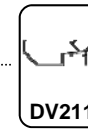

DV211



D022

10 X 2 DWARF		
Part No	mm	Quantity
DV211	3137	2
D022	3134	2
D609	1160	8
D604	1316	4
D174		8
SYBOLM6X11		8
SYBOLM6X15		12
SYBOLM6X22		16
SYNUTM6		20
Rubber	1000	19

e.g. ③

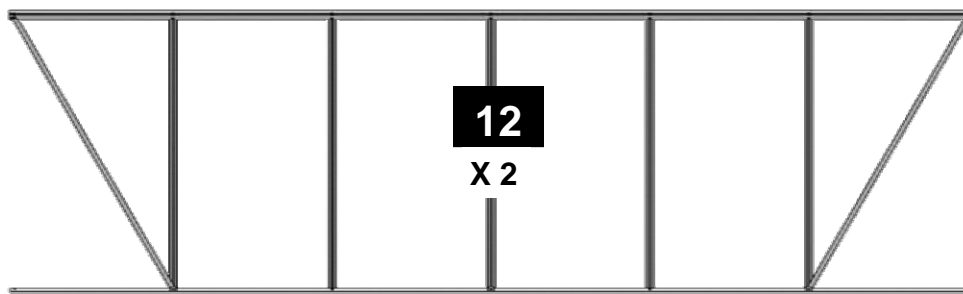

12
X 2

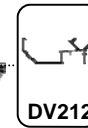

DV212



D023

12 X 2 DWARF		
Part No	mm	Quantity
DV212	3757	2
D023	3754	2
D609	1160	10
D604	1316	4
D174		8
SYBOLM6X11		10
SYBOLM6X15		14
SYBOLM6X22		20
SYNUTM6		24
Rubber	1000	24



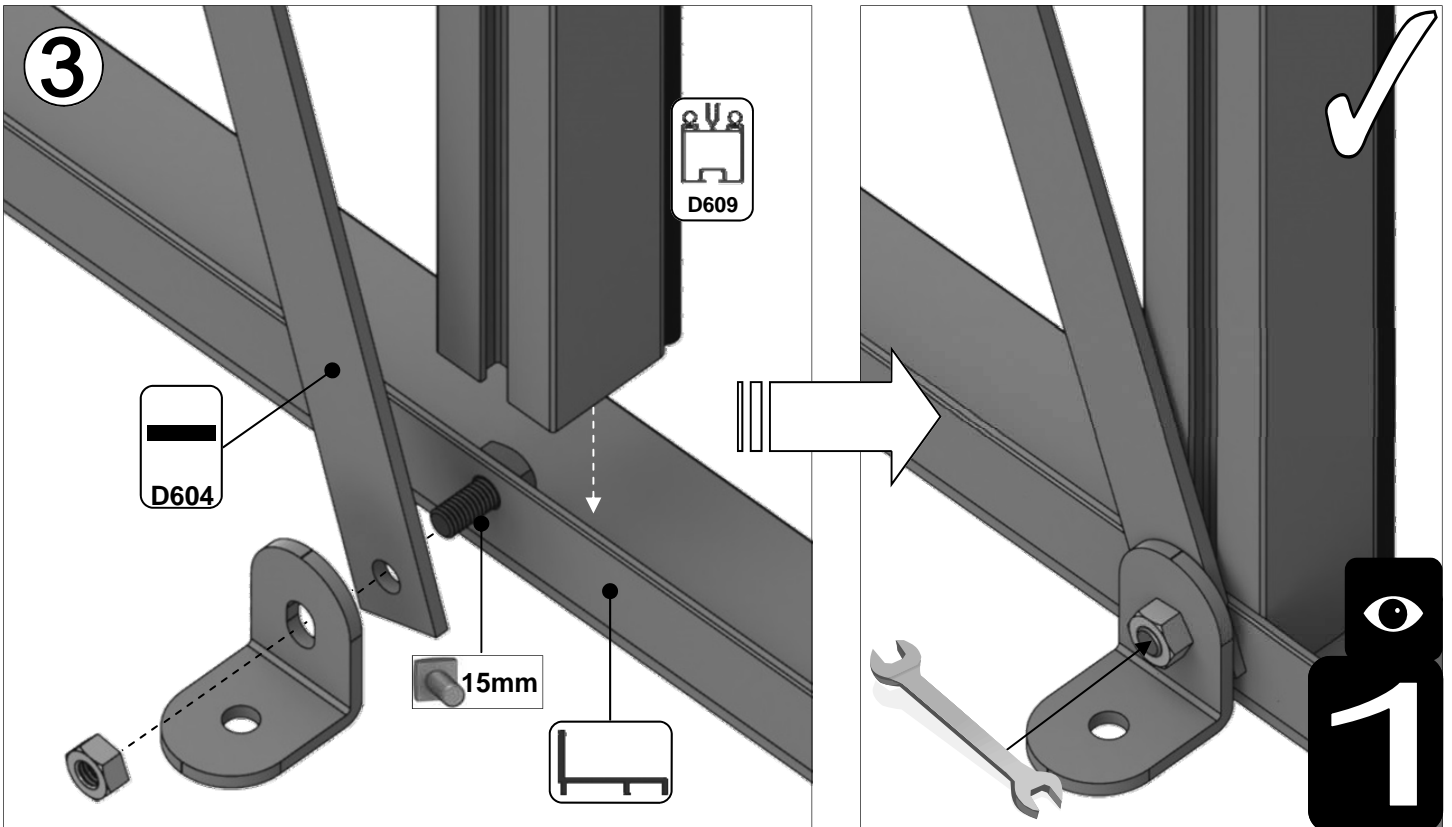
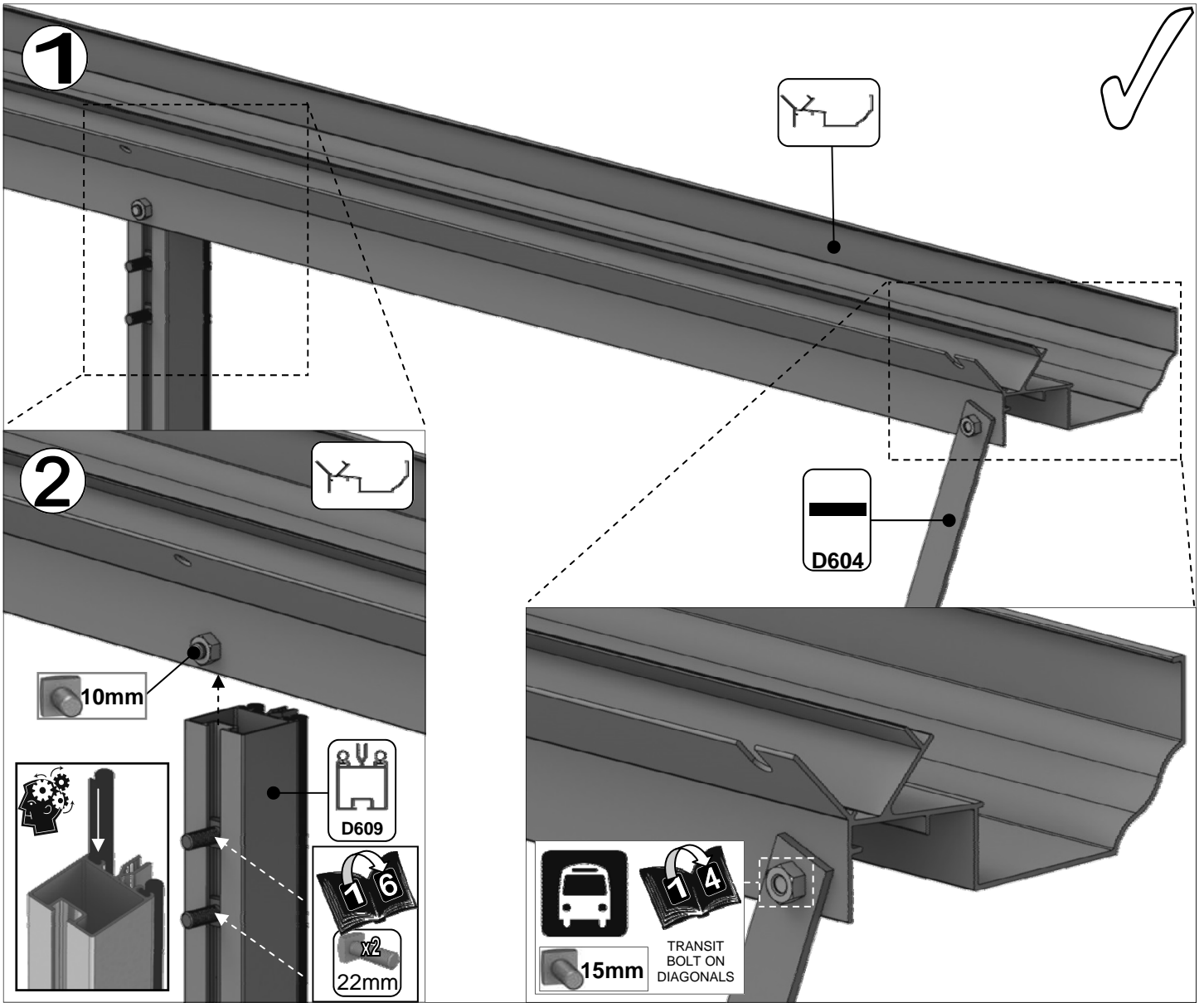

11' dwarf front

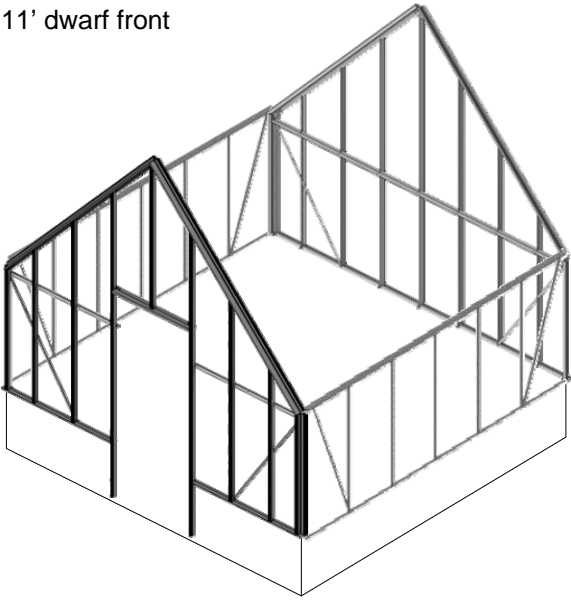

Part No	mm	Quantity
DV066L	1505	1
DV066R	1505	1
D608	1160	2
DV239L	2960	1
DV239R	2960	1
DV252L	2451	1
DV252R	2451	1
DV264	1398	1
DV271L	1249	1
DV271R	1249	1
DV275	904	1

Part No	mm	Quantity
DV303L	1319	1
DV303R	1319	1
DV307	1350	2
DV310L	1972	1
DV310R	1972	1
DV104		2
DV105		1
D163		2
D174		4
D227		35mm
M6X10		40
M6X15		10
M6NUT		50

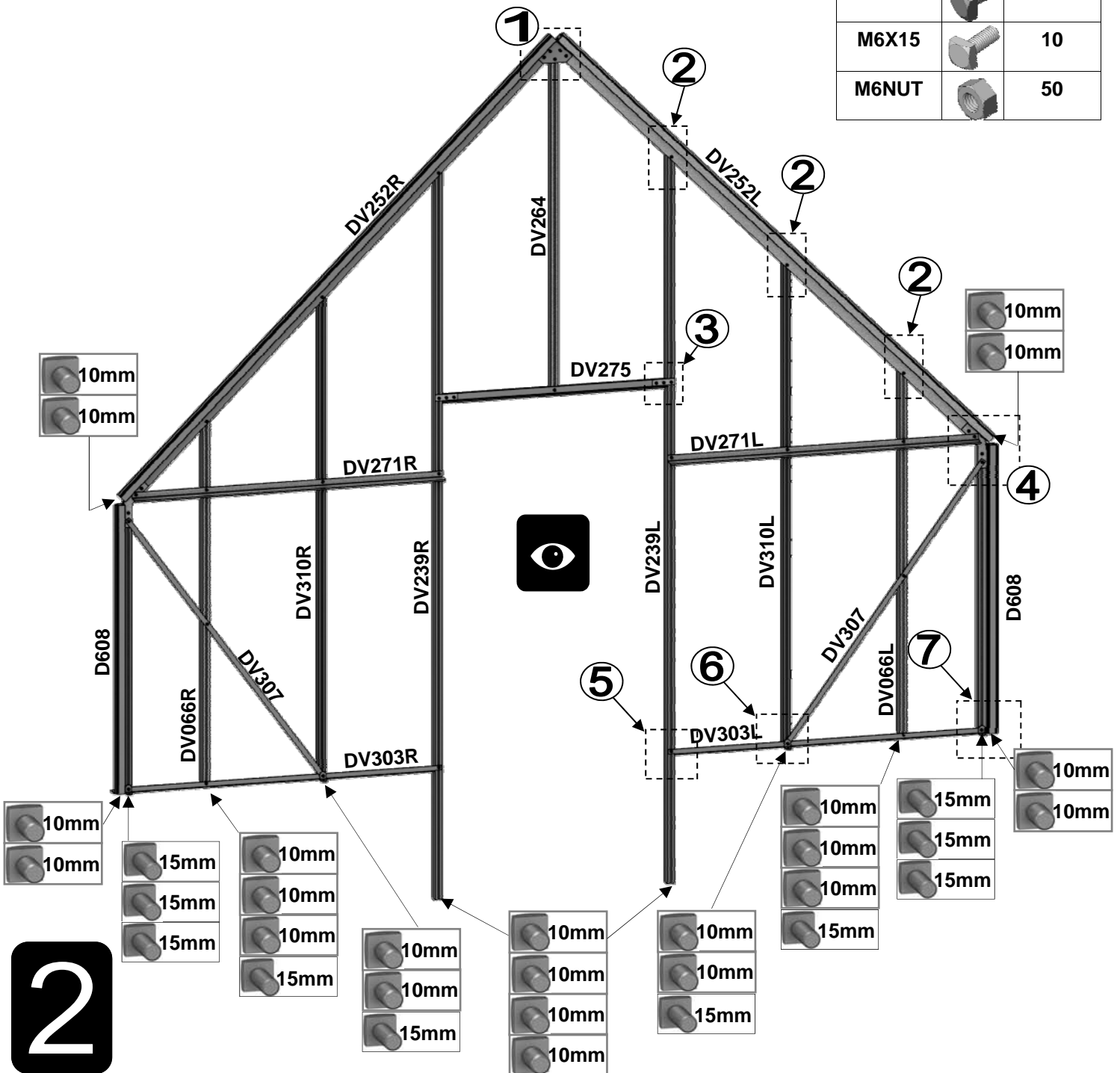

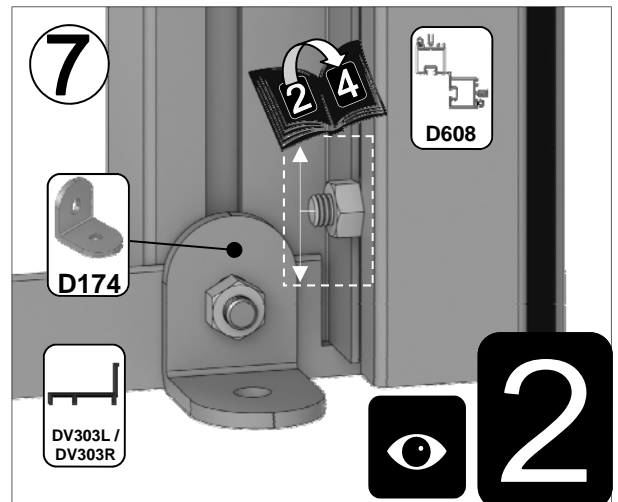
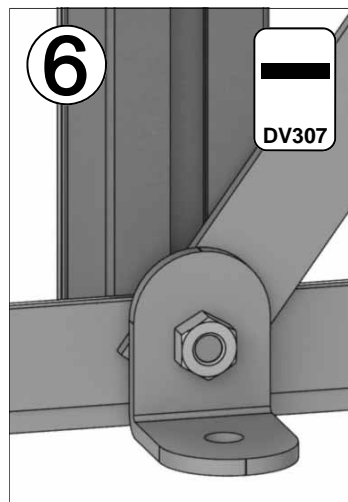
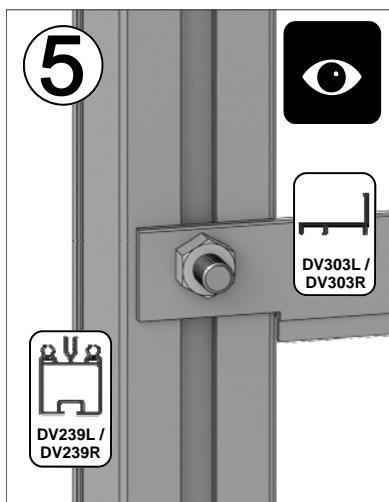
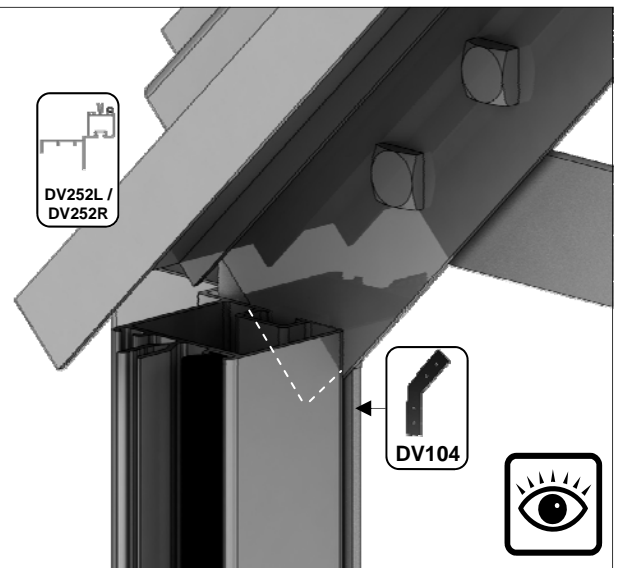
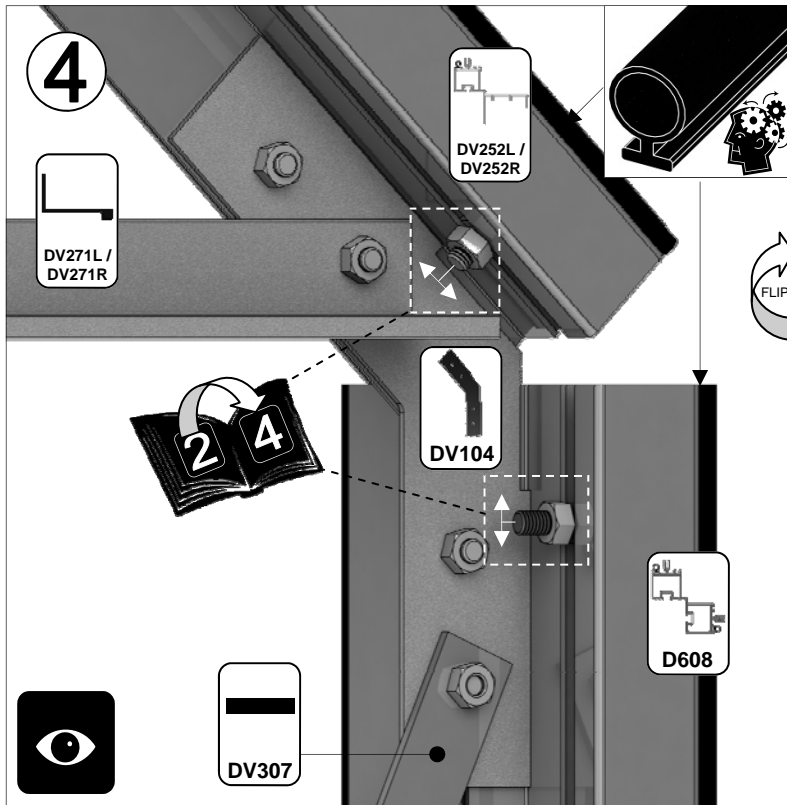
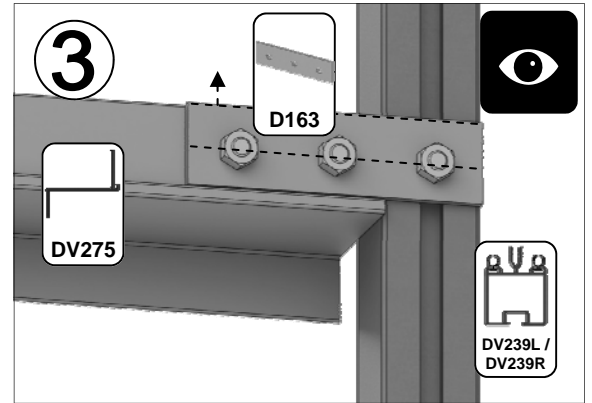
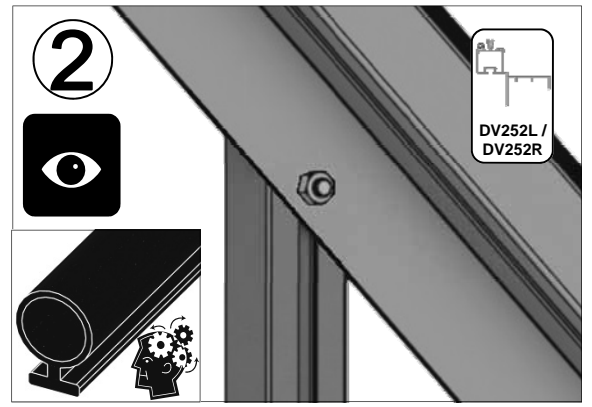
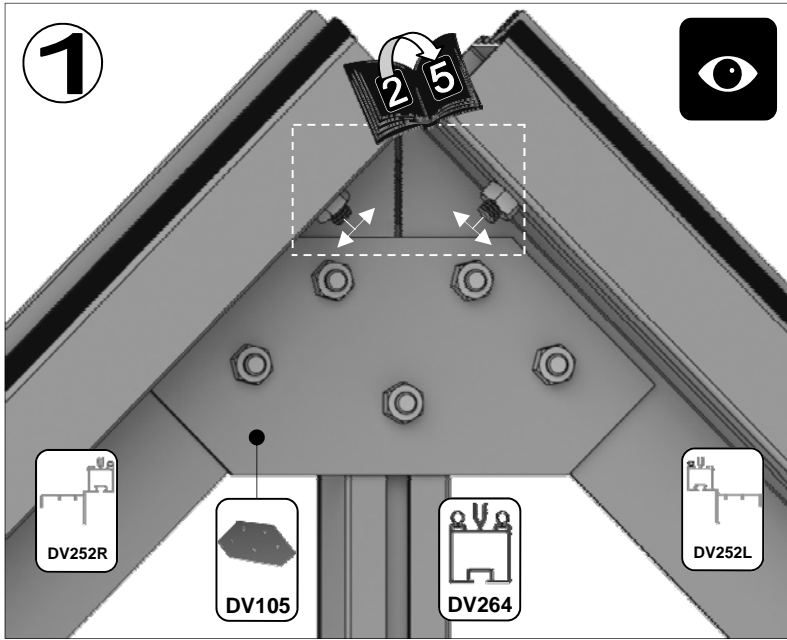

11' dwarf rear

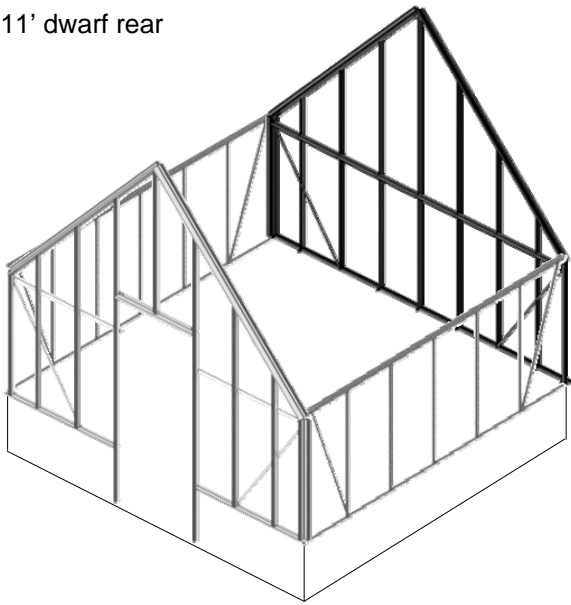

Part No	mm	Quantity
DV066L	1505	1
DV066R	1505	1
D608	1160	2
DV232	3548	1
DV252L	2451	1
DV252R	2451	1
DV259	2879	1
DV274	3402	1
DV307	1350	2
DV310L	1972	1
DV310R	1972	1
DV312L	2438	1
DV312R	2438	1

Part No	mm	Quantity
DV104		2
DV105		1
D174		7
D227		36m
M6X10		32
M6X15		13
M6NUT		45

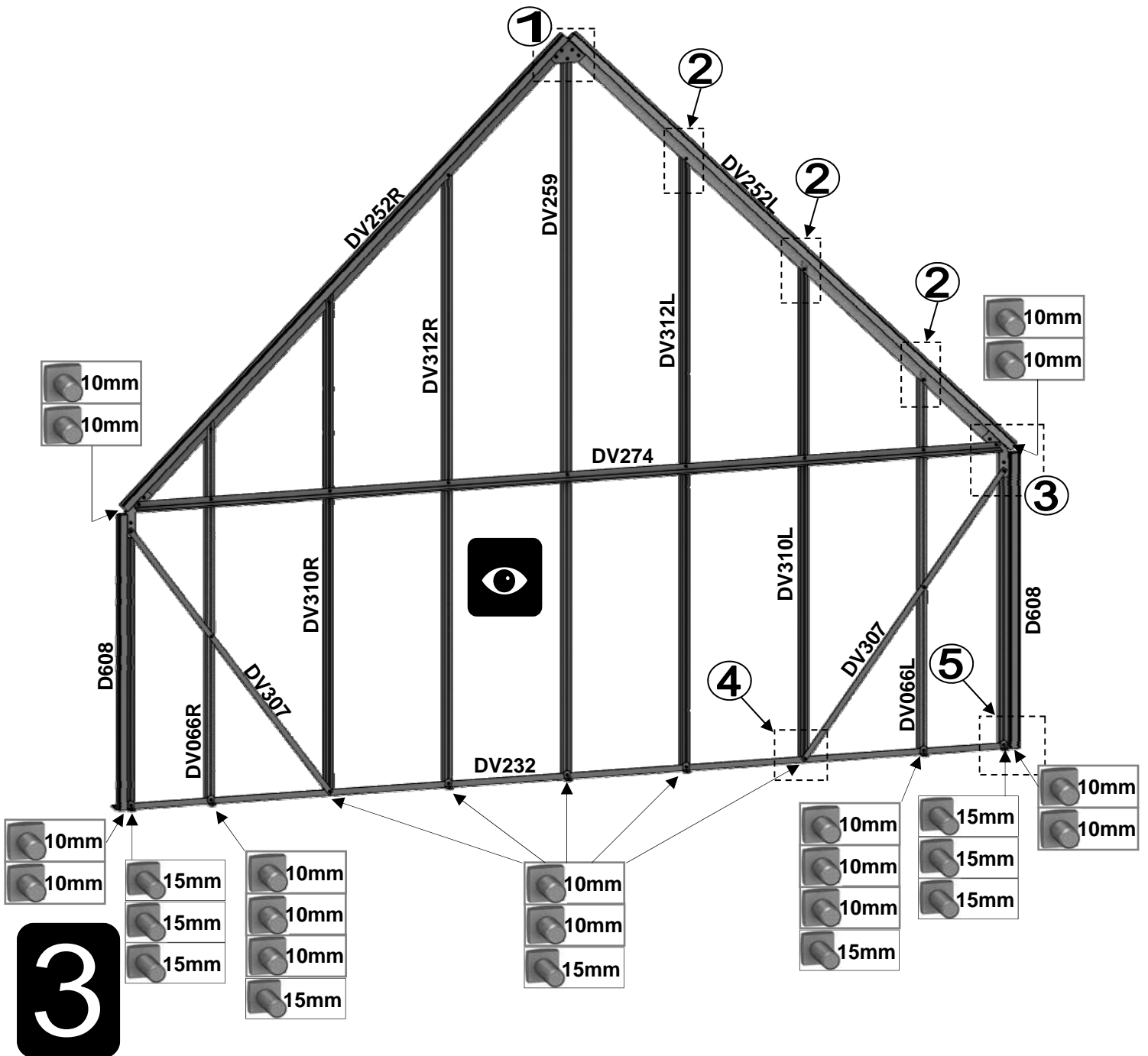

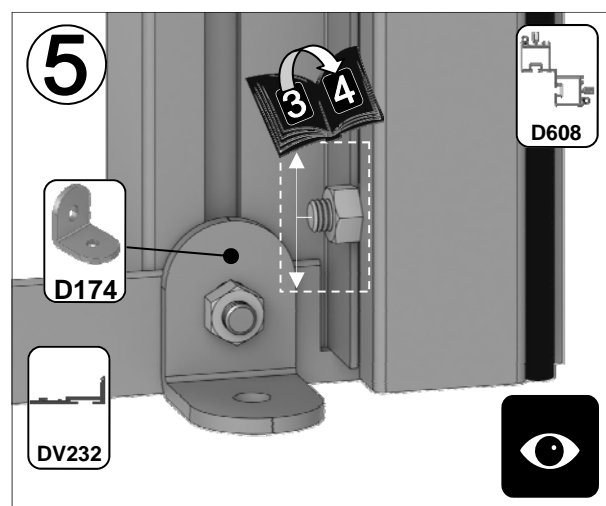
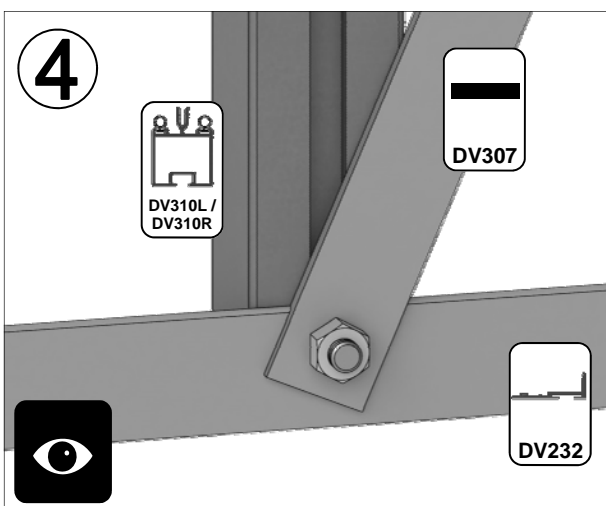
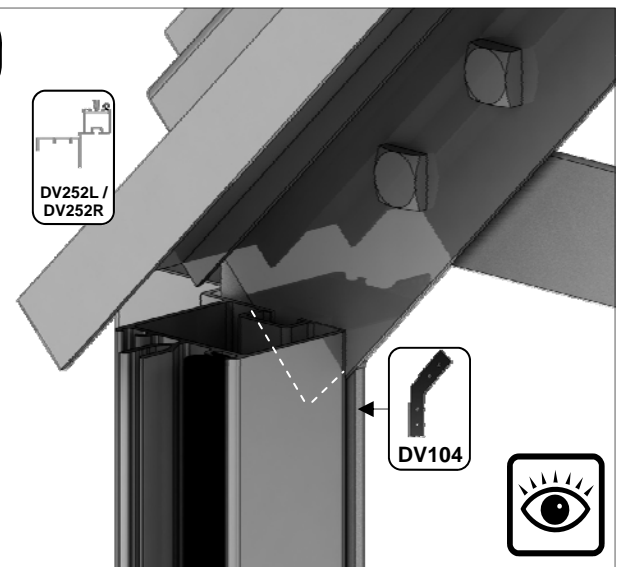
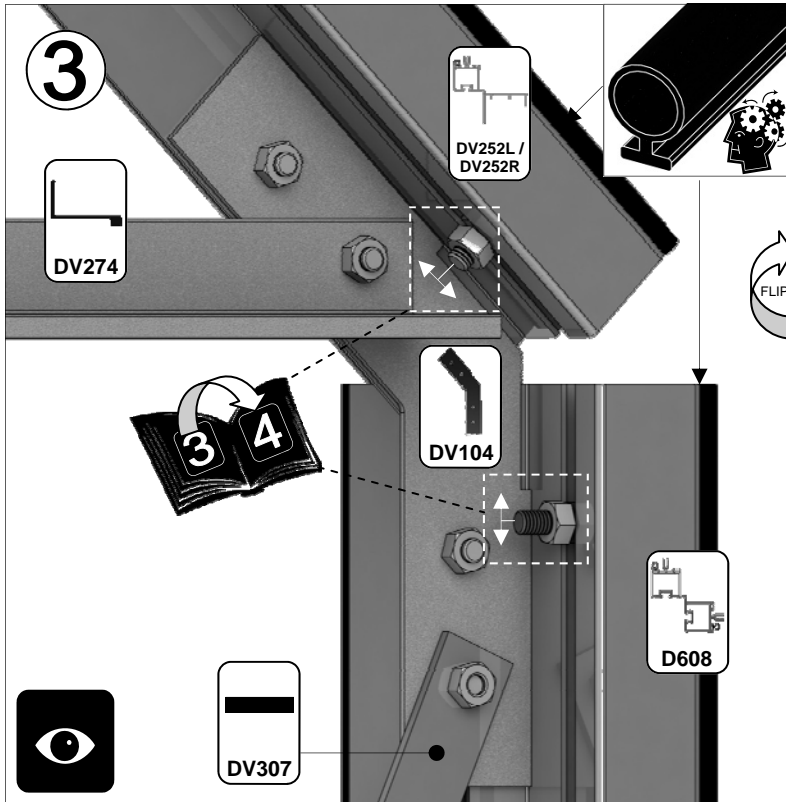
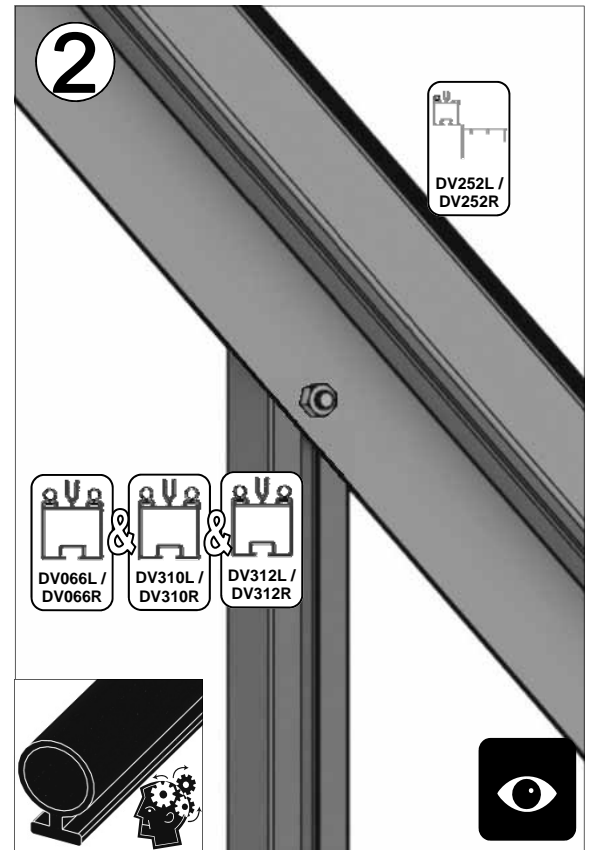
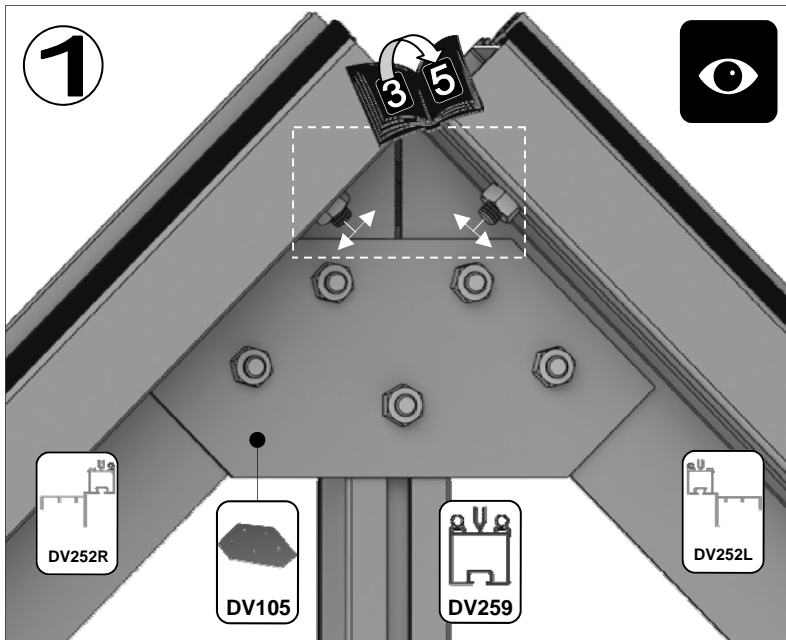

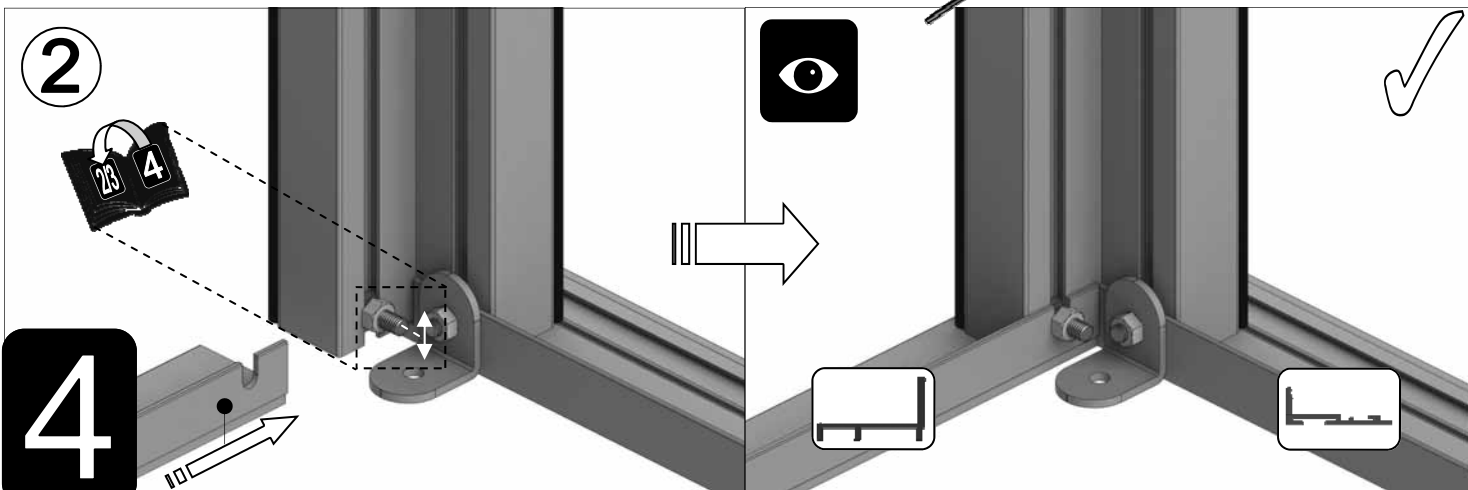
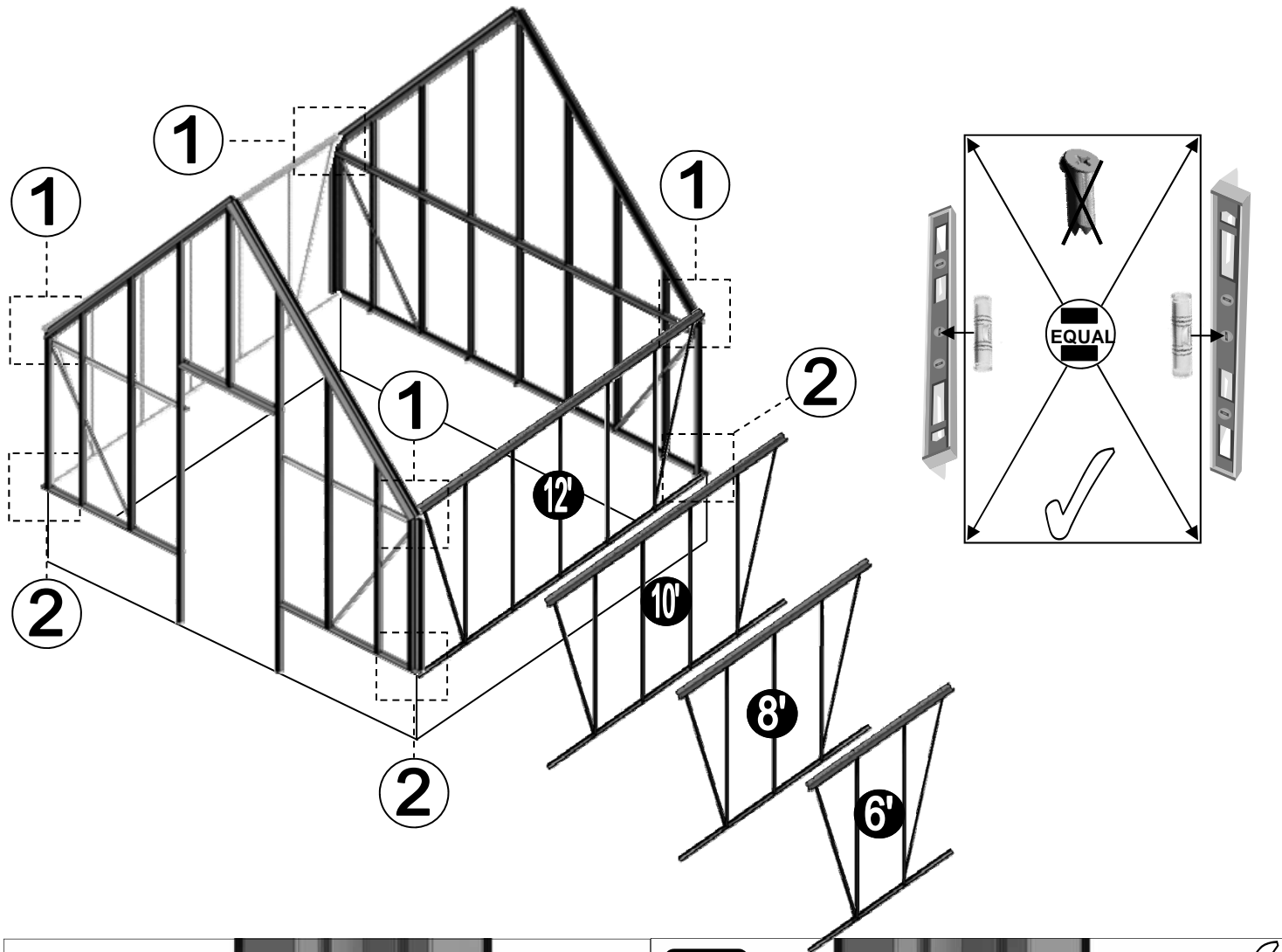
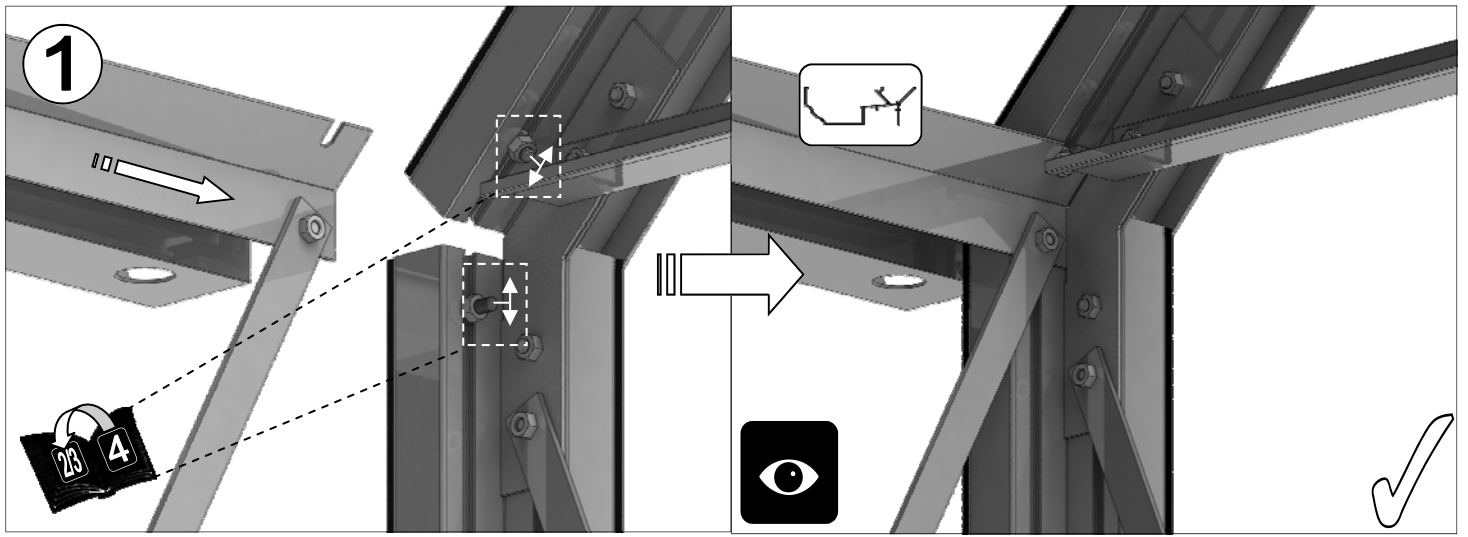

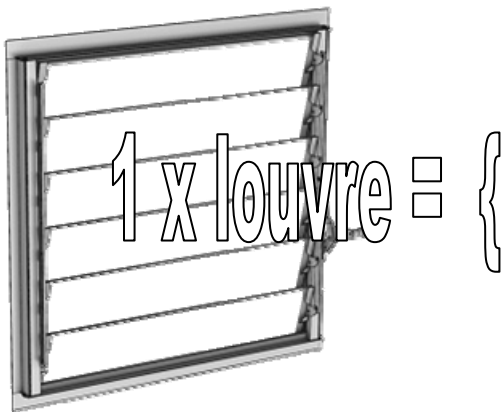



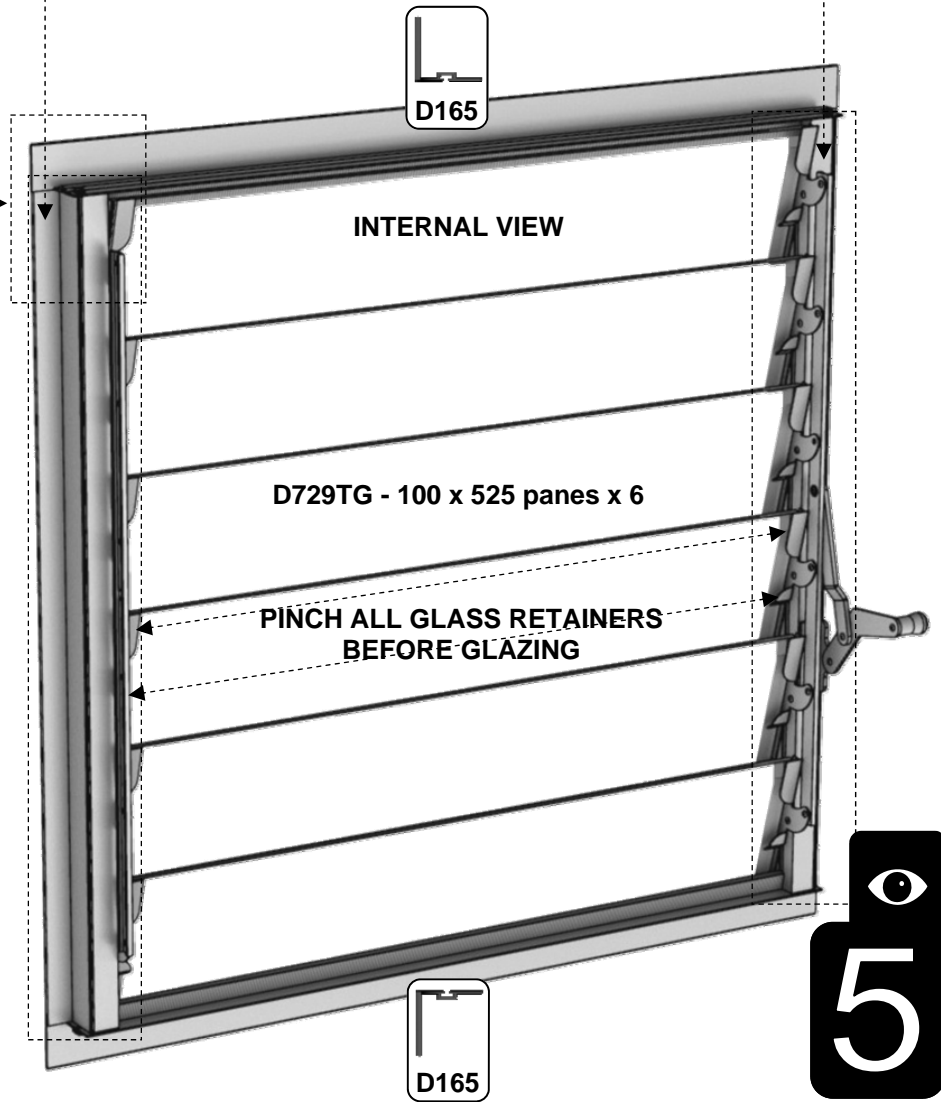
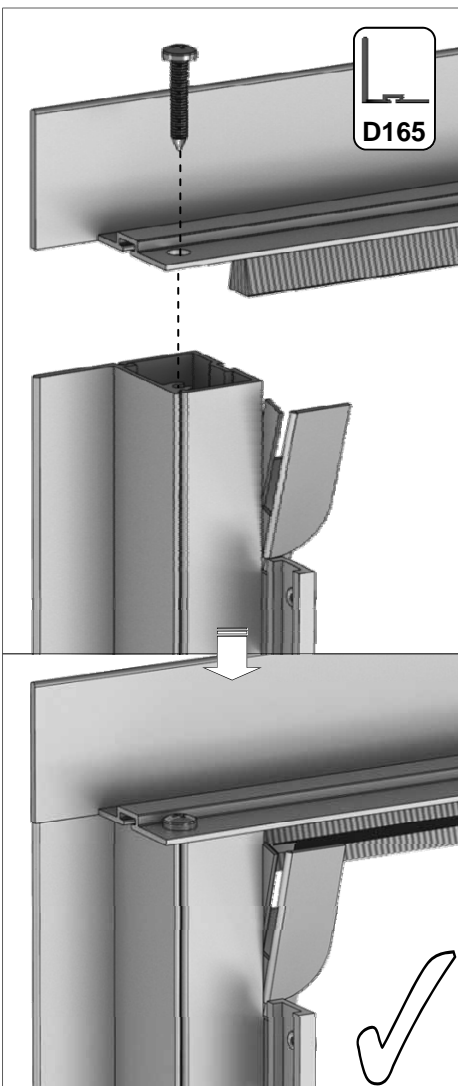
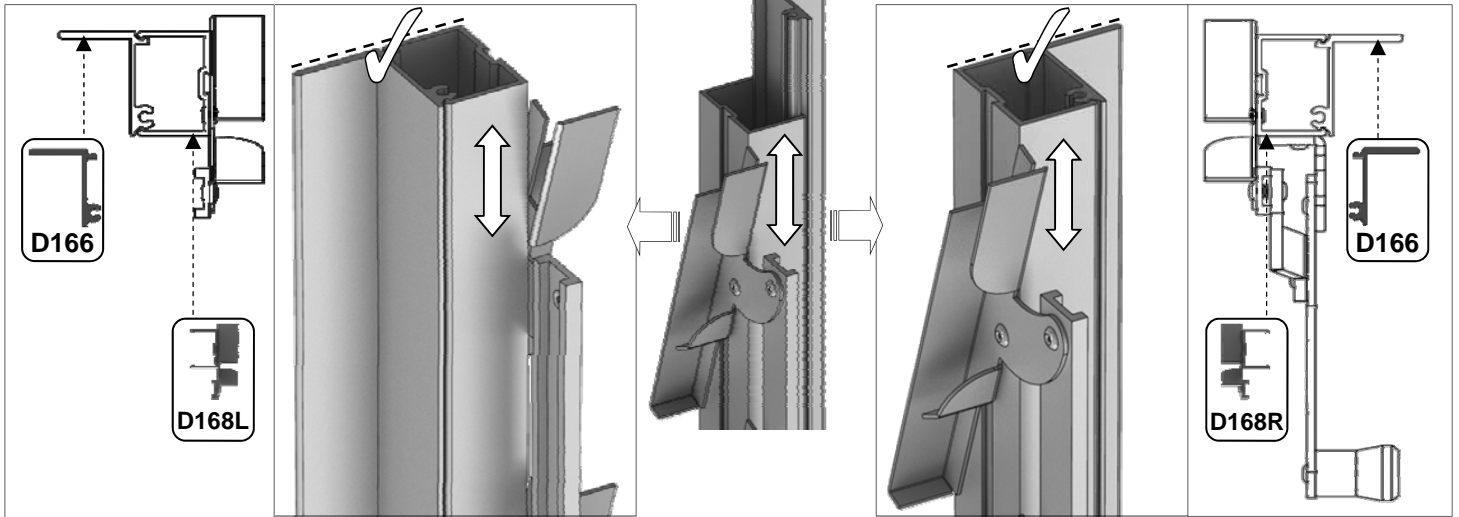







Part No		mm	Quantity
D168L		552	1
D168R (handle)		552	1
D165		612	2
D166		552	2
FS6013		12	4



6'		
Part No	mm	Quantity
DV204	1897	1
DV255	2450	4
DV100	n/a	4
DV101	n/a	2
RUBBER	1000	15
SYBOLM6X11		8
SYBOLM6X22		16
SYNUTM6		32

8'		
Part No	mm	Quantity
DV201	2517	1
DV255	2450	6
DV100	n/a	6
DV101	n/a	3
RUBBER	1000	22
SYBOLM6X11		12
SYBOLM6X22		24
SYNUTM6		48

10'		
Part No	mm	Quantity
DV202	3137	1
DV255	2450	8
DV100	n/a	8
DV101	n/a	4
RUBBER	1000	30
SYBOLM6X11		16
SYBOLM6X22		32
SYNUTM6		64

12'		
Part No	mm	Quantity
DV203	3757	1
DV255	2450	10
DV100	n/a	10
DV101	n/a	5
RUBBER	1000	36
SYBOLM6X11		20
SYBOLM6X22		40
SYNUTM6		80

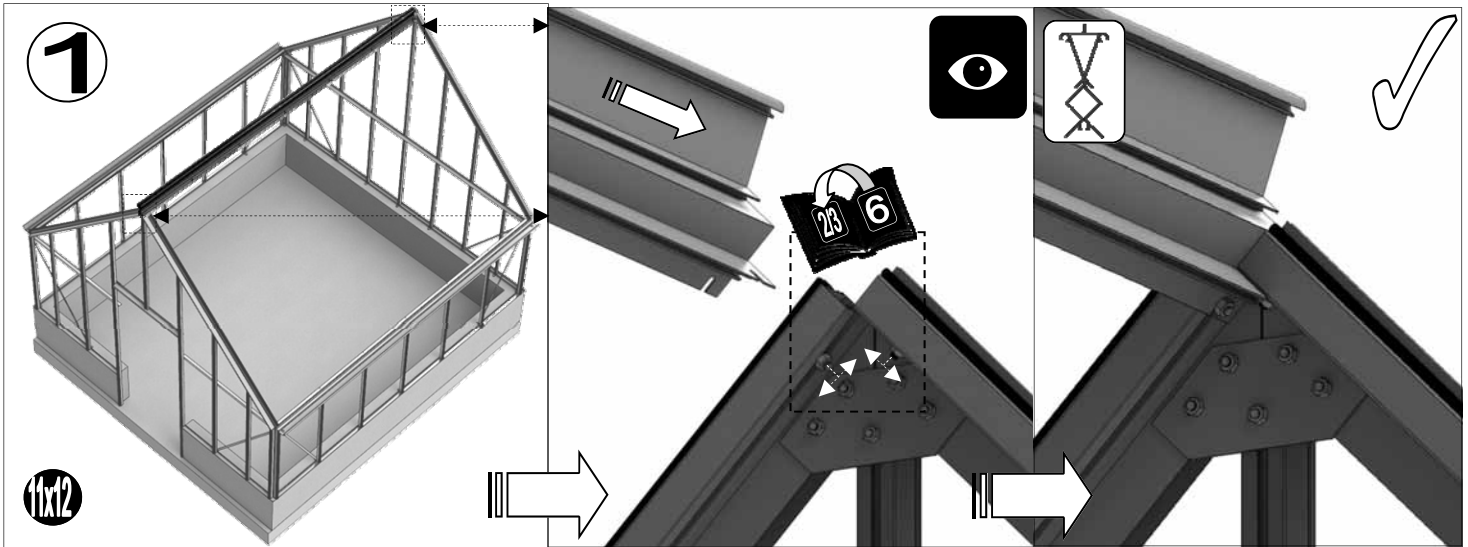

2

- End finials need to be pinched onto the ridge using 'DV282' grub screws.
- Depending on your ridge length a half cresting may need to be cut. Some spacer bar may also be required 'DV281' cut into two equal sections.
- Each finial and cresting piece needs to be siliconed 'D119' into place.

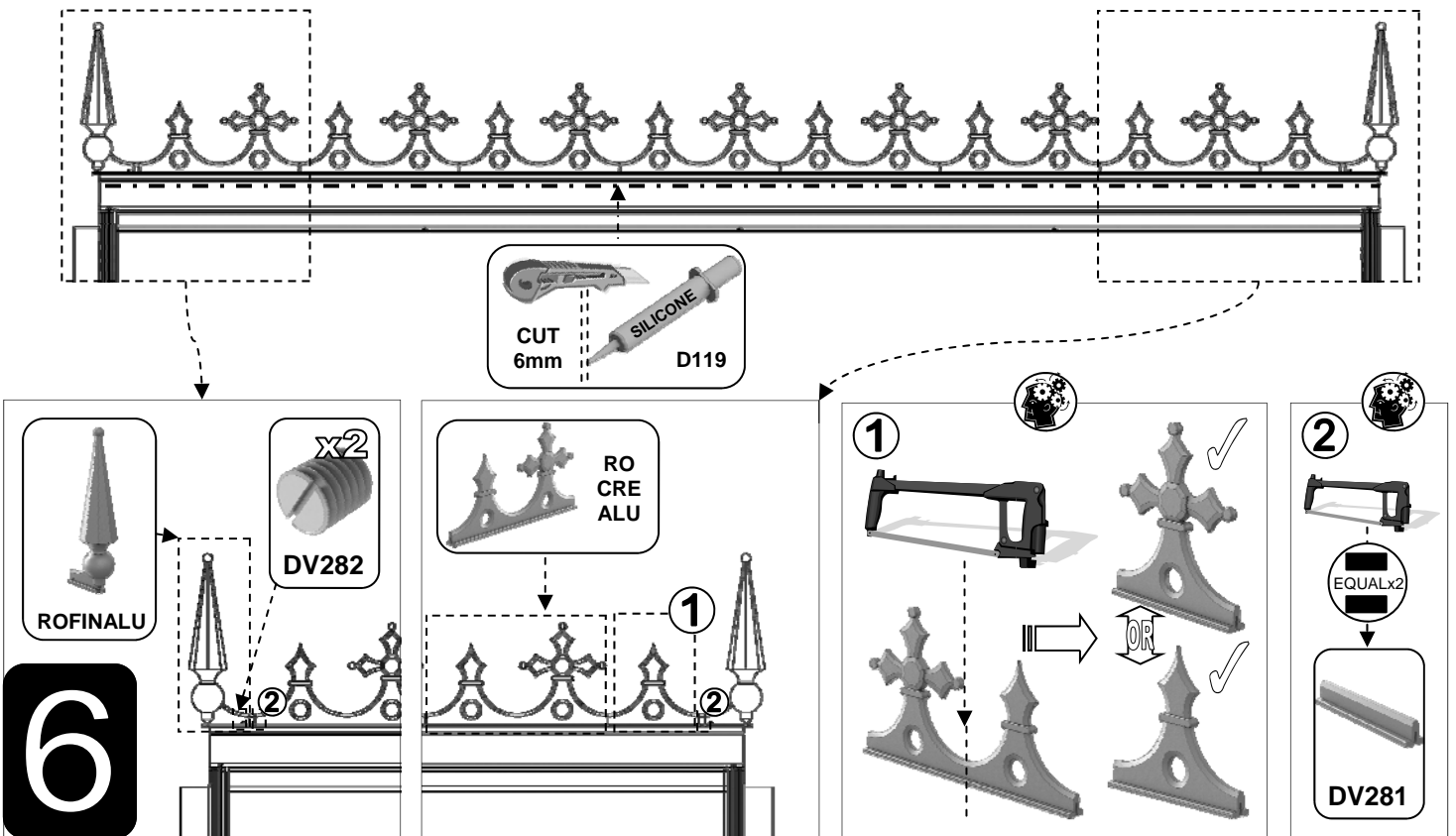

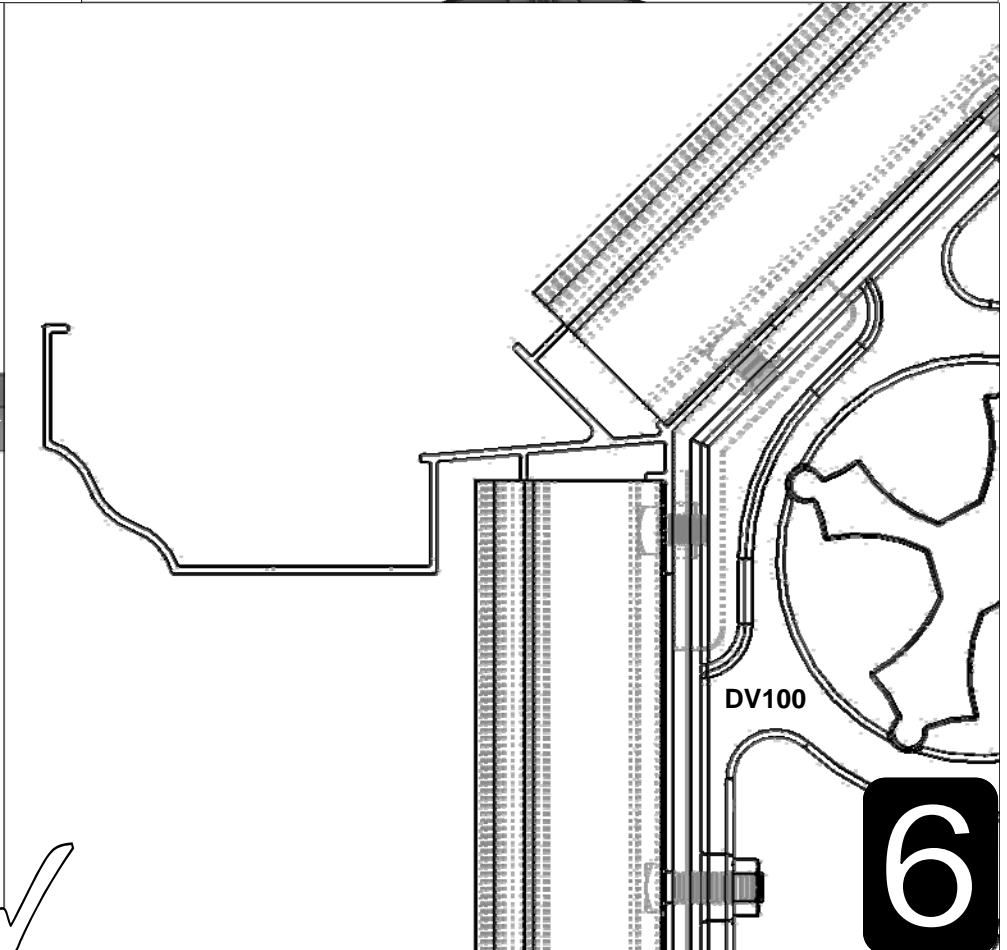
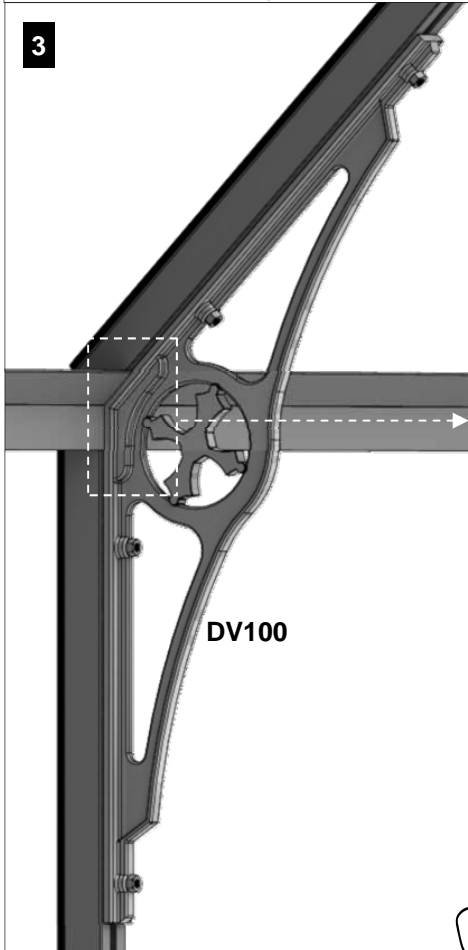
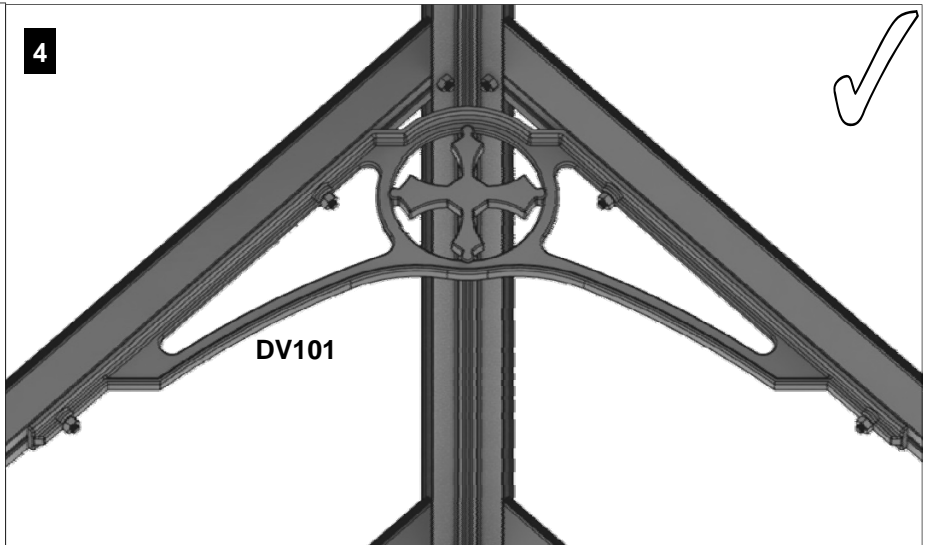
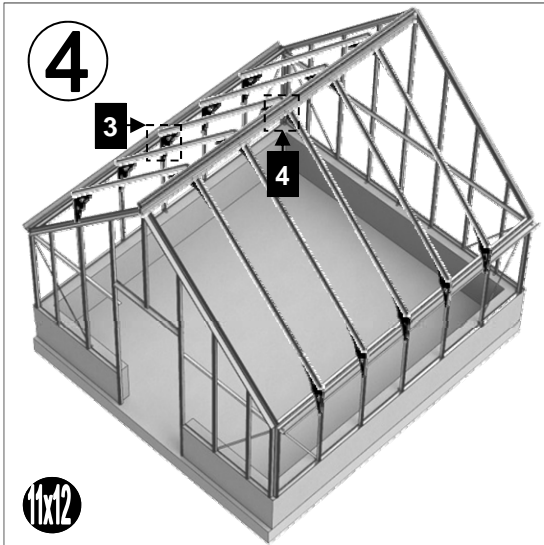
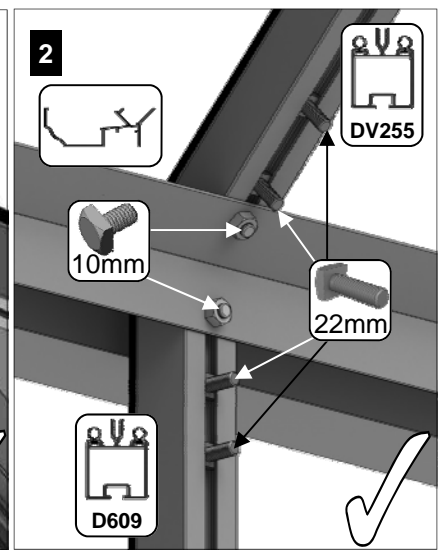
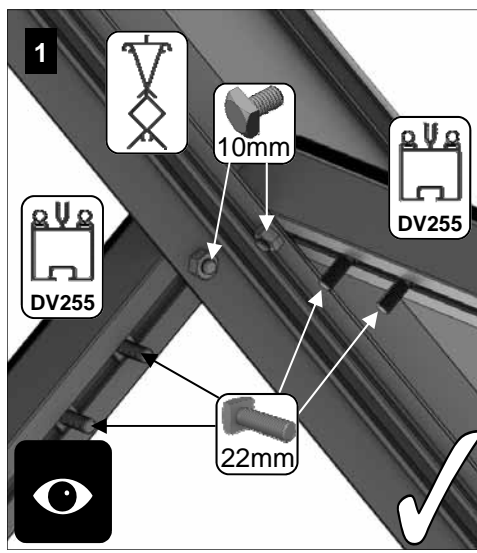
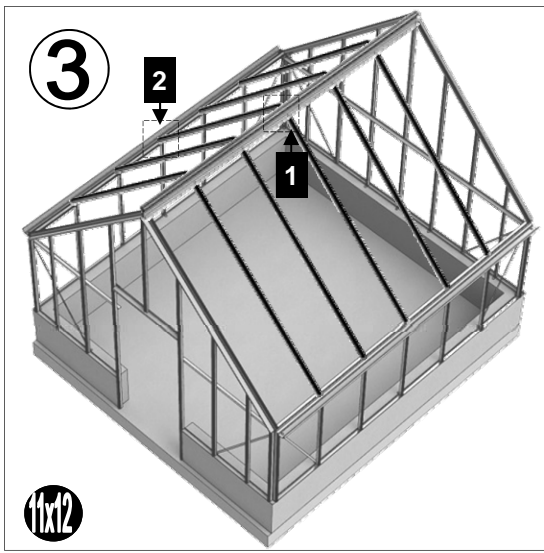





D1208
1 of -
610 x 610
pane

Part No		mm	Quantity
D866		639	1
D863L		613	1
D863R		613	1
D862		593	1

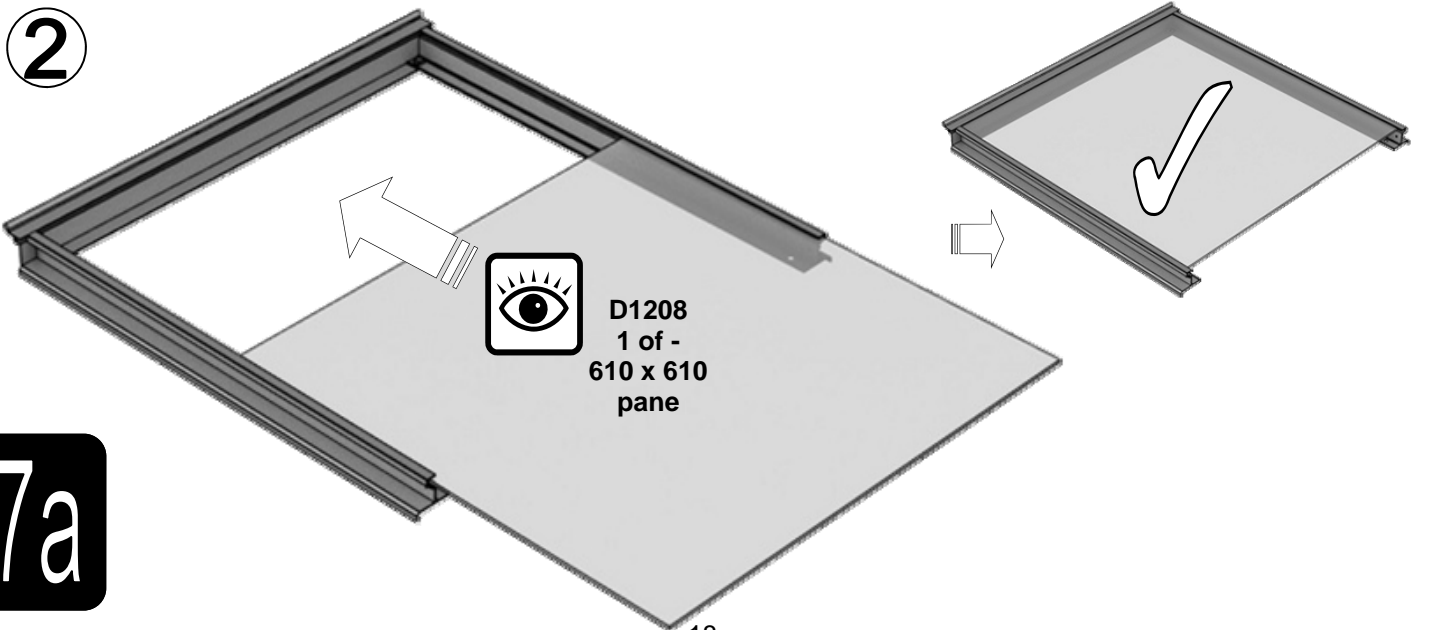
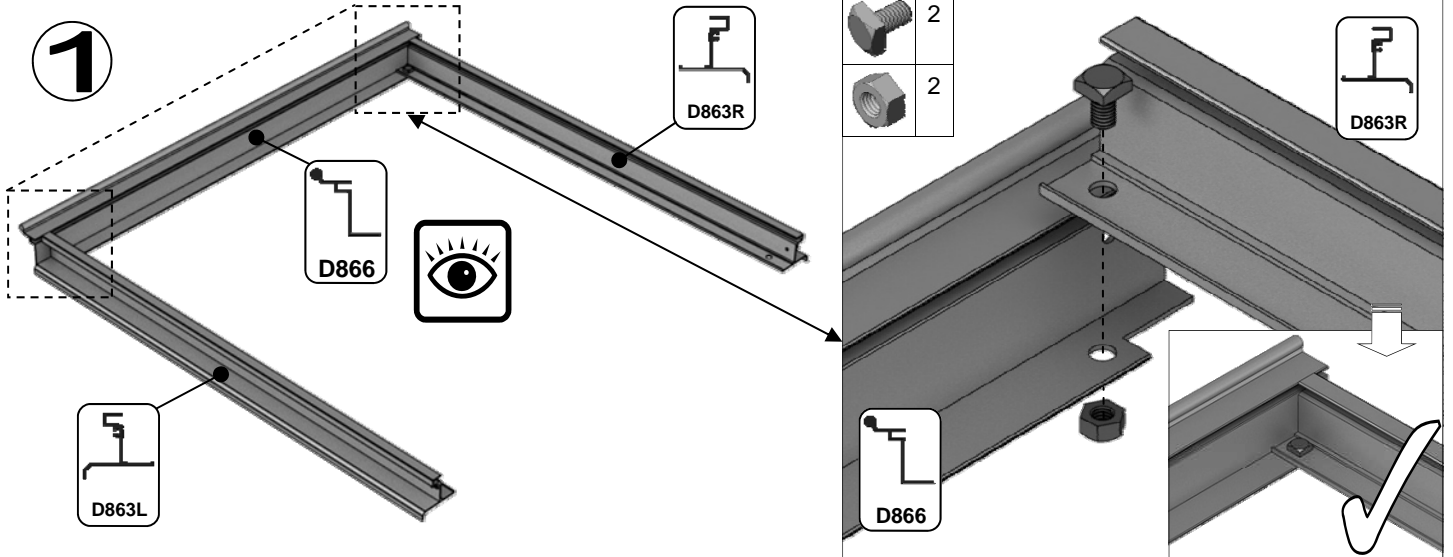
Part No		mm	Quantity
D220 PLUS SCREW		N/A	2
D205		N/A	2
SY-BOLM6X11		10	4
SYNUTM6		M6	4
8 X 12 S/T FS6017		10	2
8 x 19 S/T FS6018		19	2



7a

3 

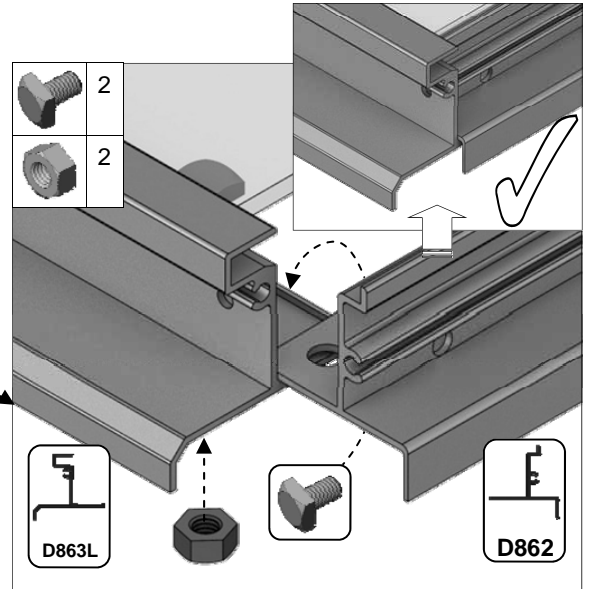
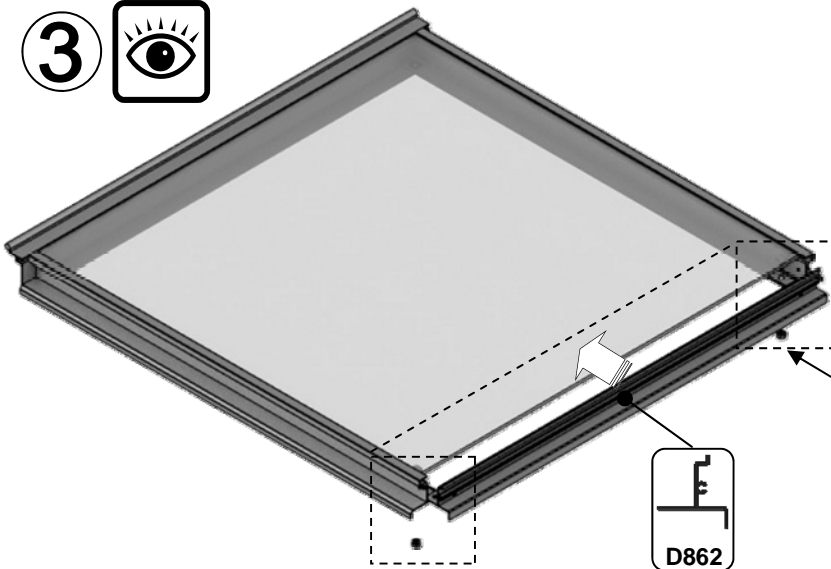

4 

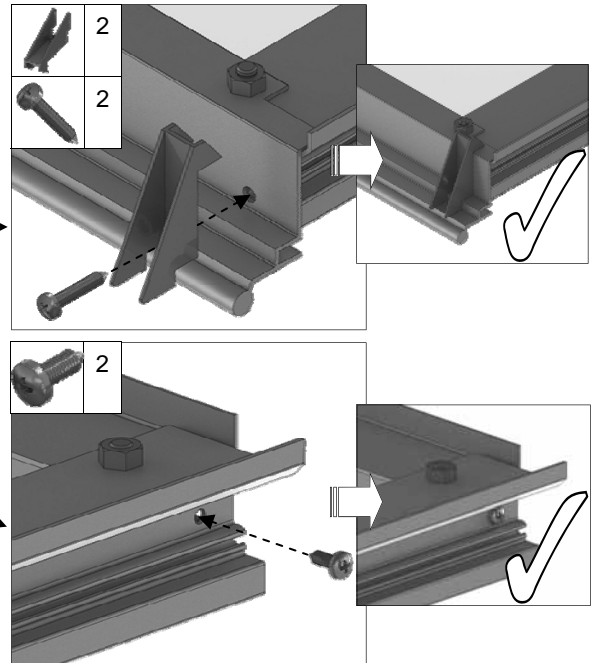
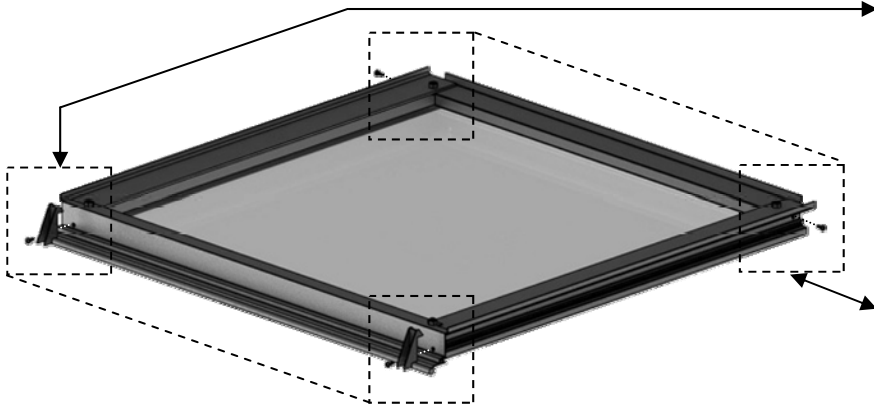
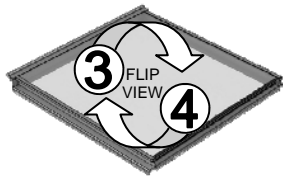



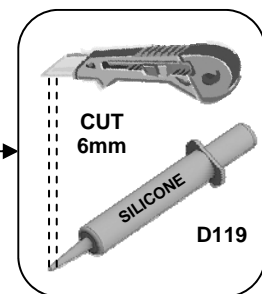
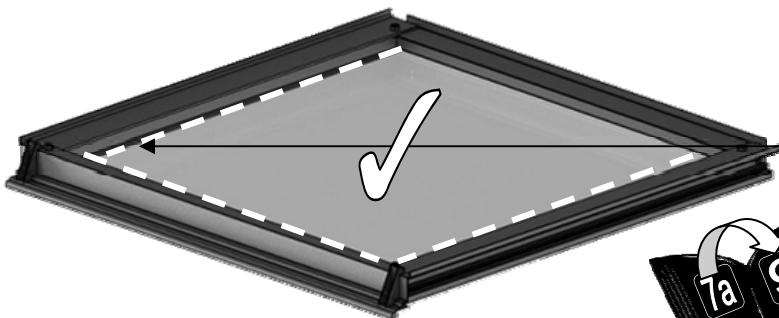



5 



7a

1 vent
slam bar = {

Part No		mm	Quantity
SY-BOLM6X11		10	2
SY-BOLM6X15		15	2
SYBOLM6 X11CROP		10	2
SYNUTM6		N/A	4

Part No		mm	Quantity
D079 PLUS FLUFF		590	1
D114		N/A	2

6

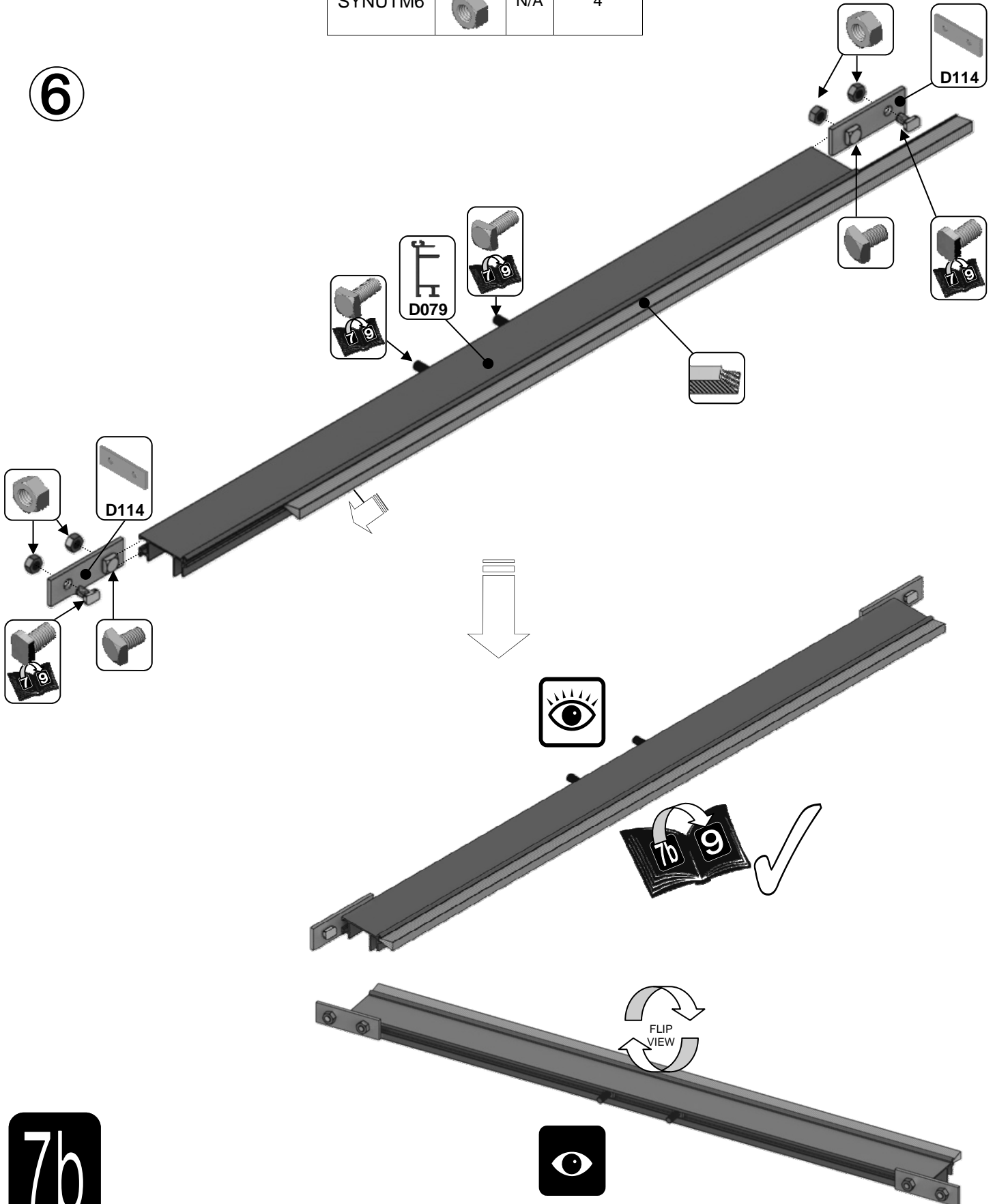

7b



7b

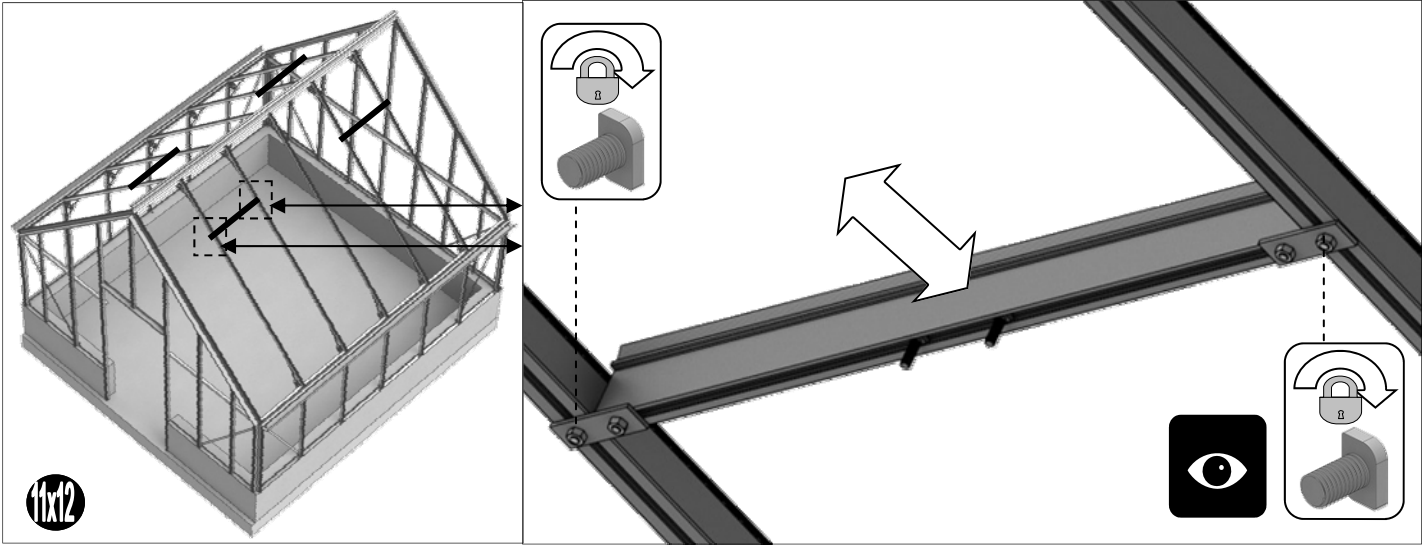
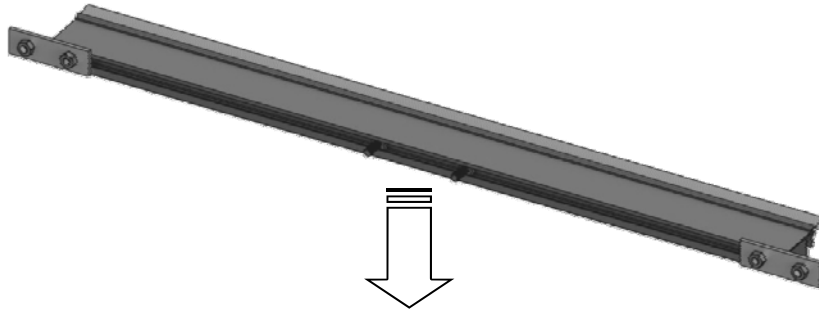

fix12

GLAZING (plans pto):

Glass and aluminium can potentially cause injury. Please ensure you wear protective goggles, gloves, headgear and suitable footwear when assembling and glazing the building.

Please remember that glass is fragile and should be handled with extreme care. Always clear up and dispose of any breakages immediately.

Layout the plastic bar cappings e.g. D618 and covers e.g. D619 around the building like a sundial checking that all is present and correct, see right and pto. You can also place the roof cappings in the gutters so they are closer to hand.

Use the capping e.g. 618 and the self tapping screws to then hold the glass in place. The covers then enclose the screw heads giving a neat finish e.g. D619.

IMPORTANT: On the roof sections please make sure that you place a screw around 25mm / 1" from the bottom of each capping strip (create a hole in the plastic if required) and that the screws are nice and tight to avoid any glass slippage.



8

PART No	Section	Size (mm)
D618		1144
DV403L/R		1505
DV479		1384
DV610L/R		1972
DV612L/R		2438
DV639L/R		2960
DV655		1880
DV659		2879
DV664		1373
D870		601
D610		1160
D620		1144
D871		601
DV652		1871
D614		1162
D619		1144
DV480		1384
DV611L/R		1972
DV613L/R		2438
DV615L/R		1505
DV640L/R		2960
DV658		2481
DV665		2879
DV670		1373

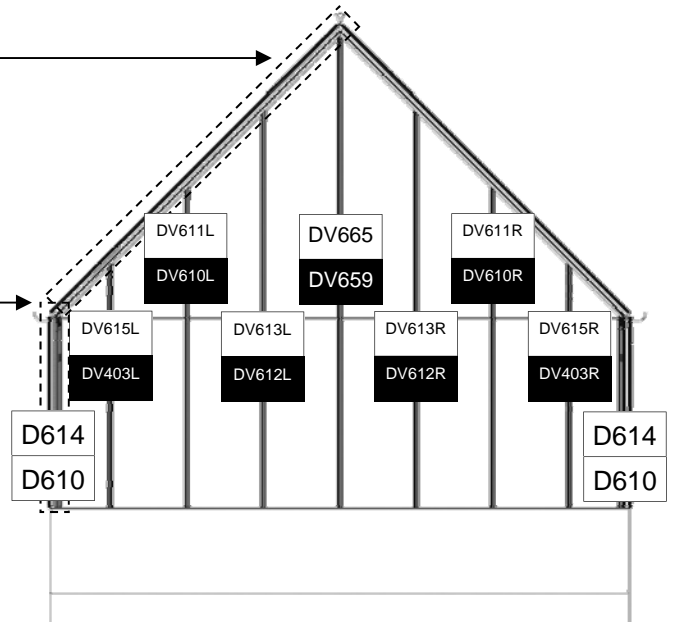
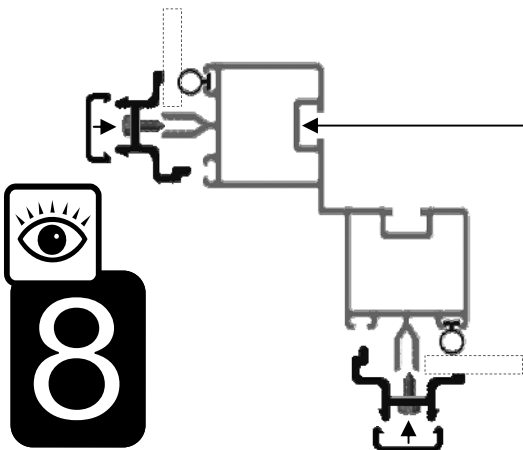
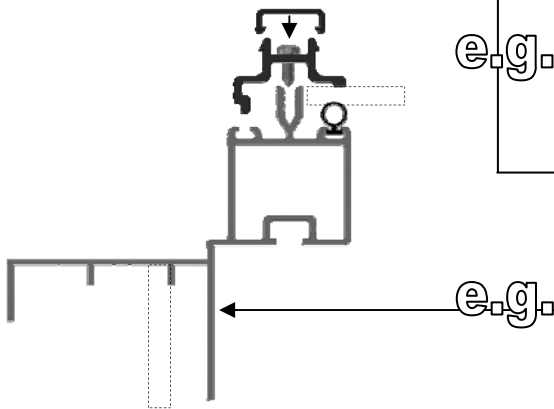
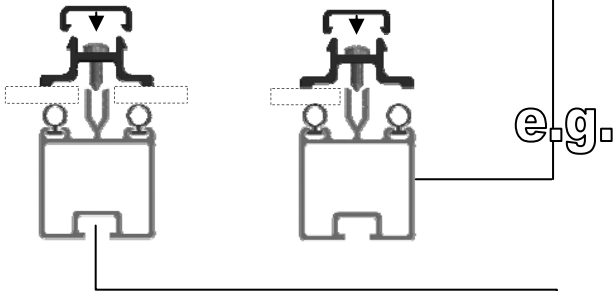
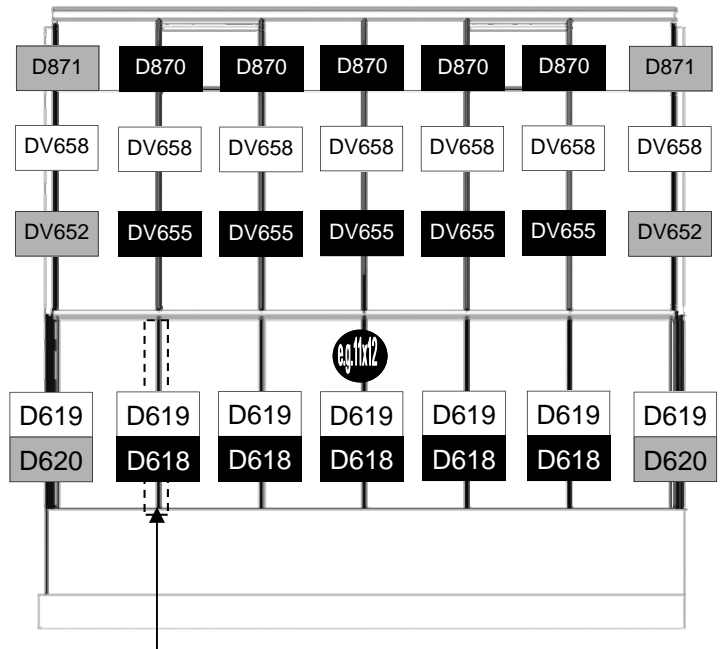
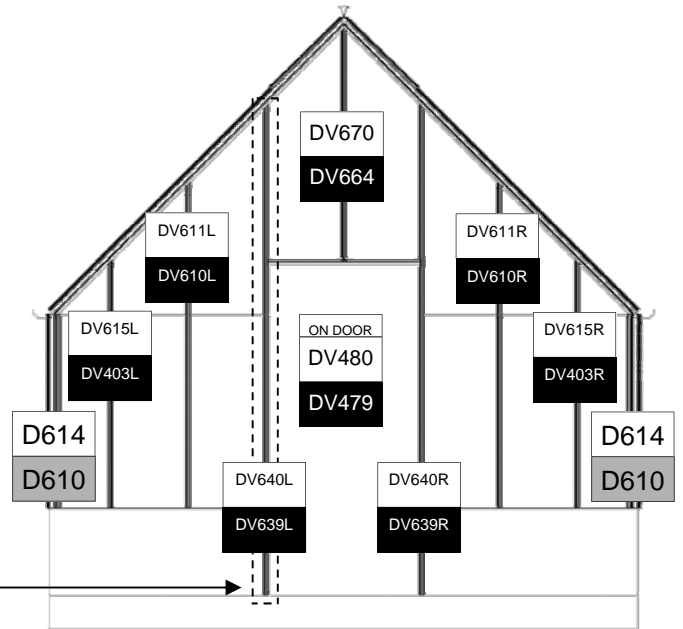

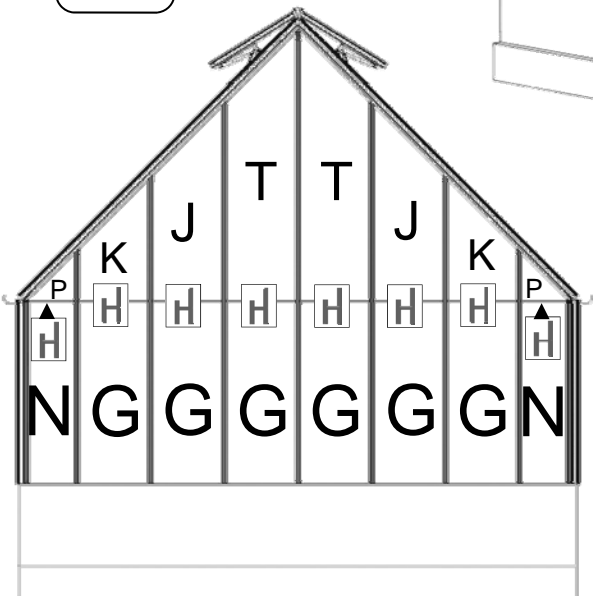
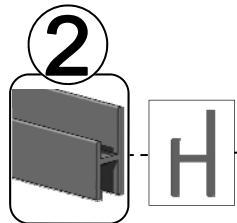
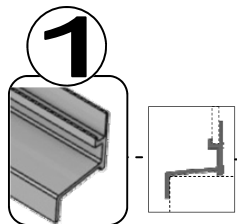
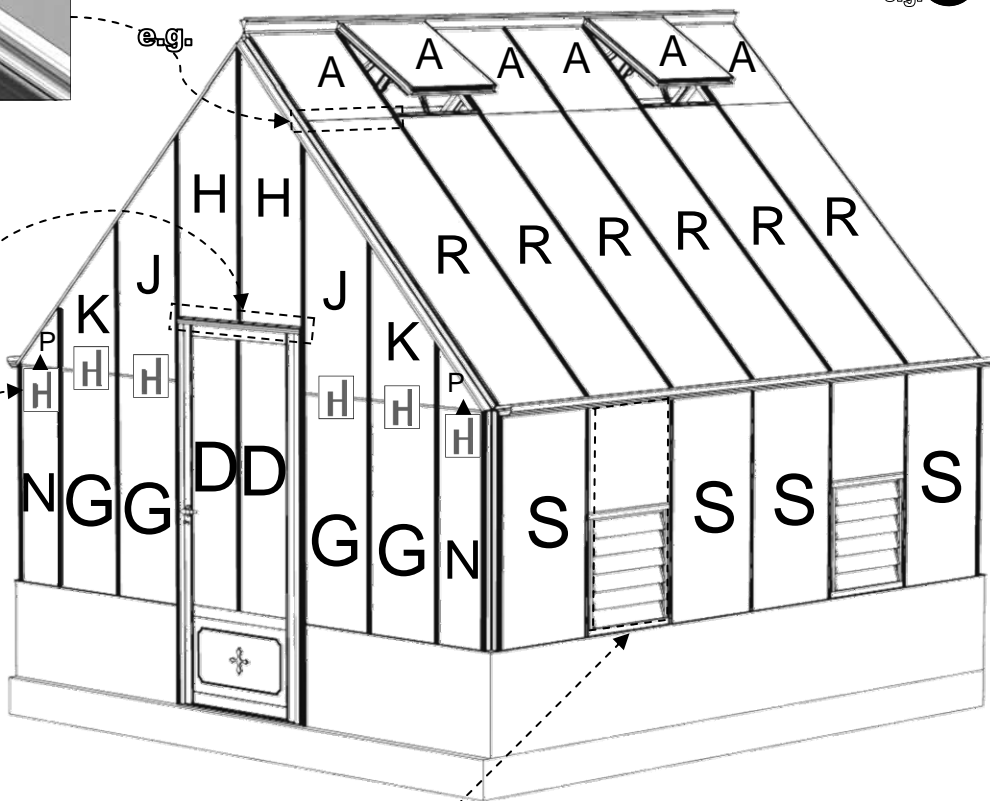
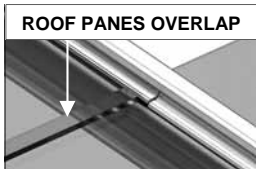

D624	M	610 X 550	1
D729	L	525 X 100	6
D101 / ROSEPS	H	610 long	1

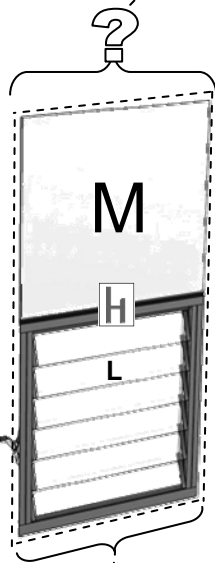

PART No		Size (mm)	6'	8'	10'	12'
D1216	S	610 X 1162	4	6	8	10
610x1890	R	610 X 1890	6	8	10	12
D1208	A	610 X 610	6	8	10	12
D625	N	305 X 1162	4			
D769	G	457 X 1162	10			
DV700	D	357 X 1384	2			
DV507	P	ANGLE	4			
DV713	K	ANGLE	4			
DV714	J	ANGLE	4			
DV716	T	ANGLE	2			
DV717	H	ANGLE	2			
D223/B		Cut to 904mm	1			
D101 / ROSEPS	H	610 long (inc cuts to 457&305mm)	12 + (1 per louver)			

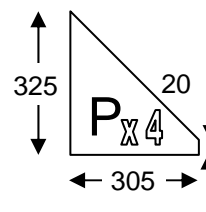
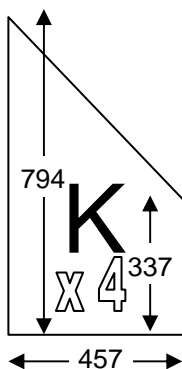
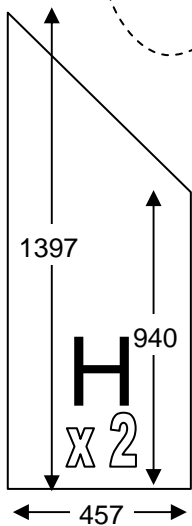
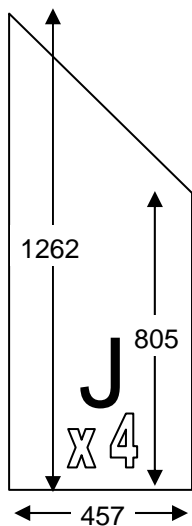
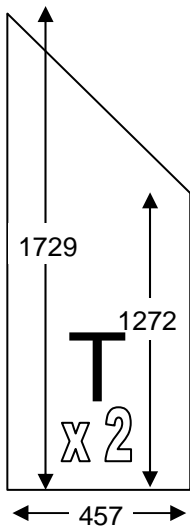

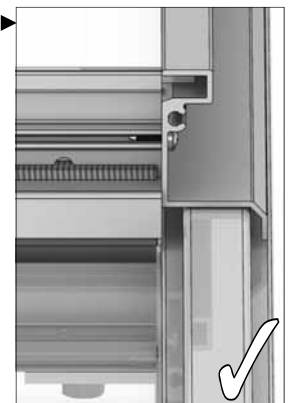
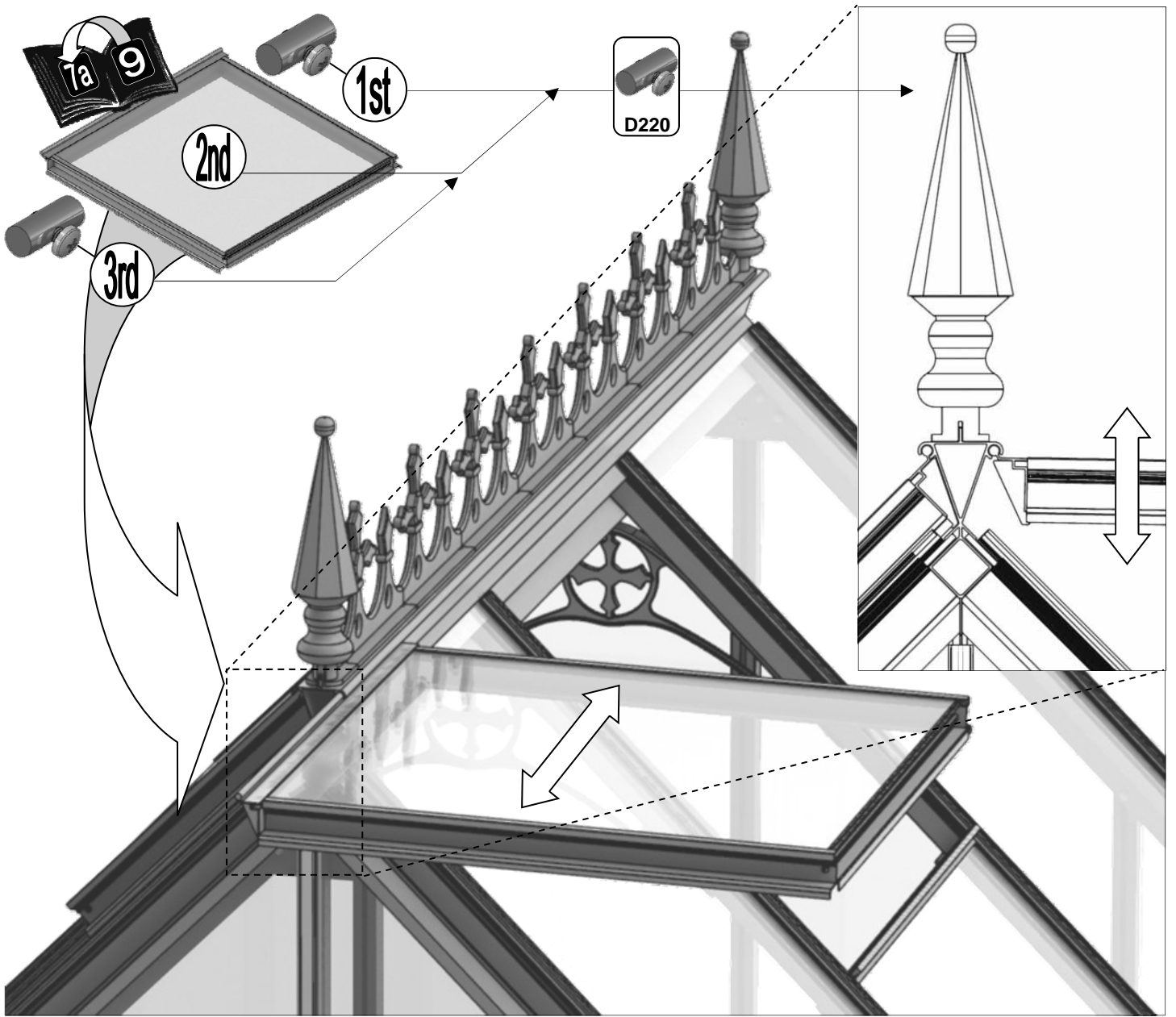

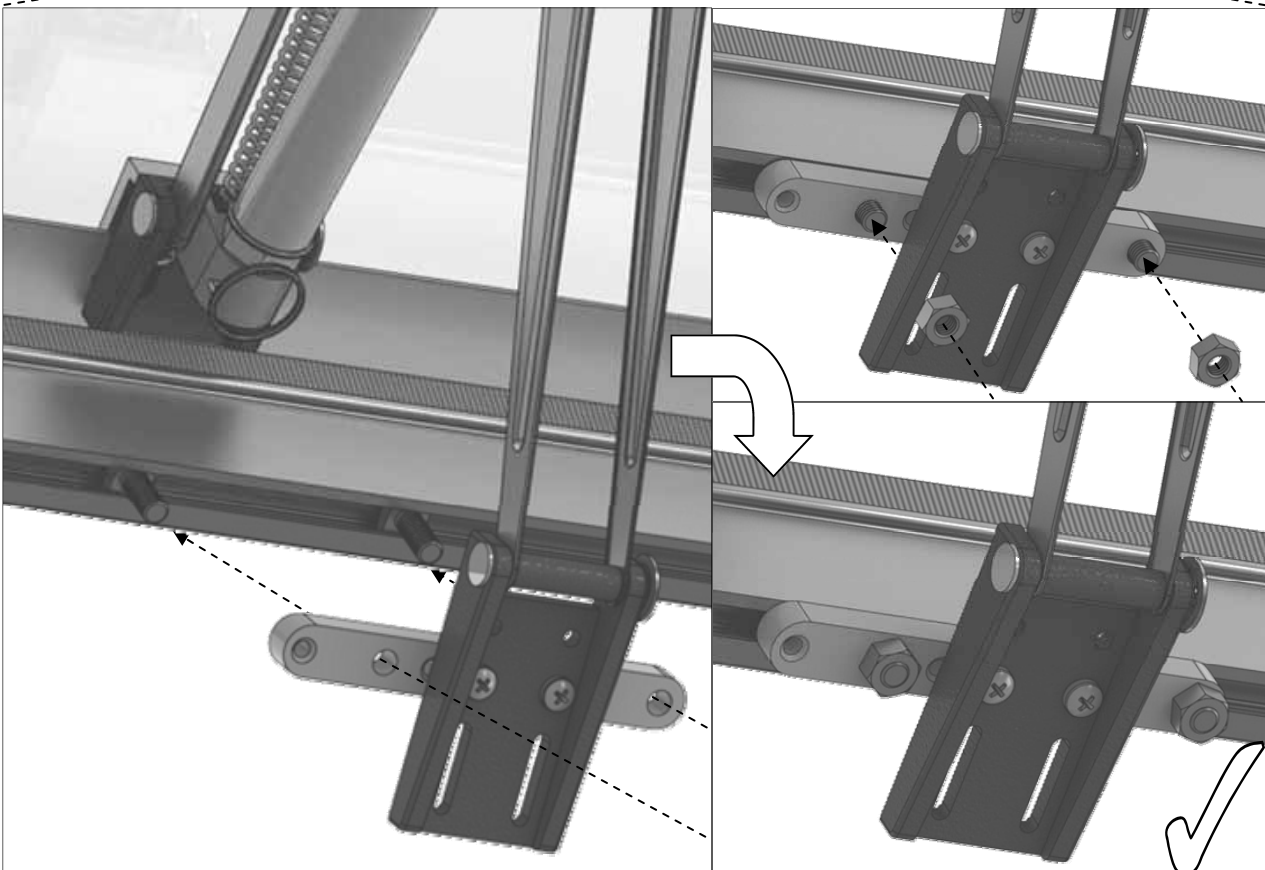
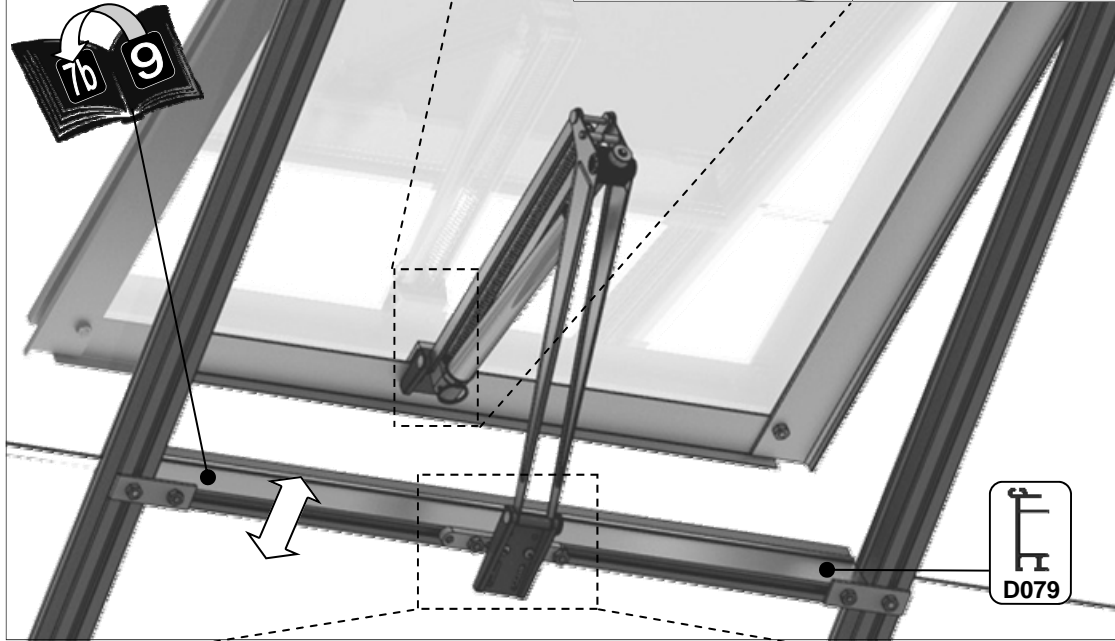
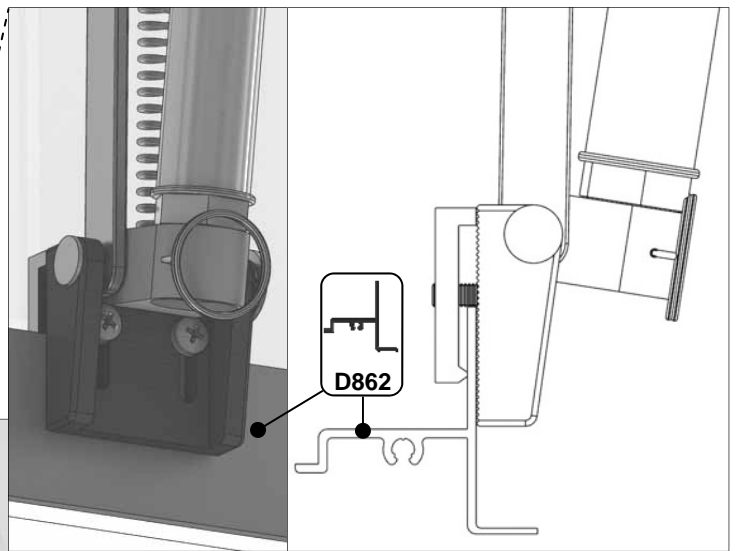
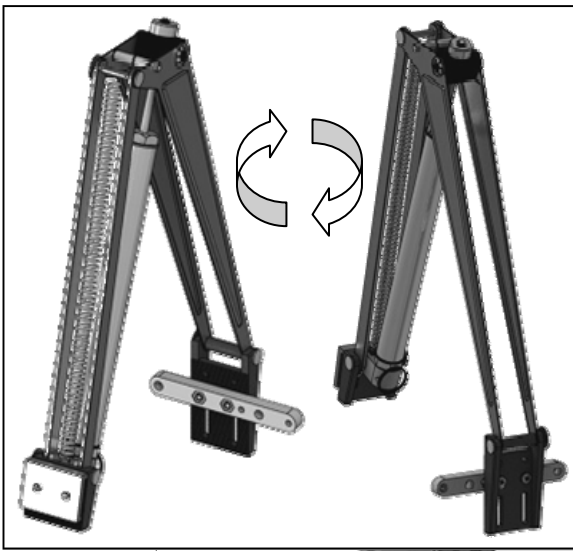

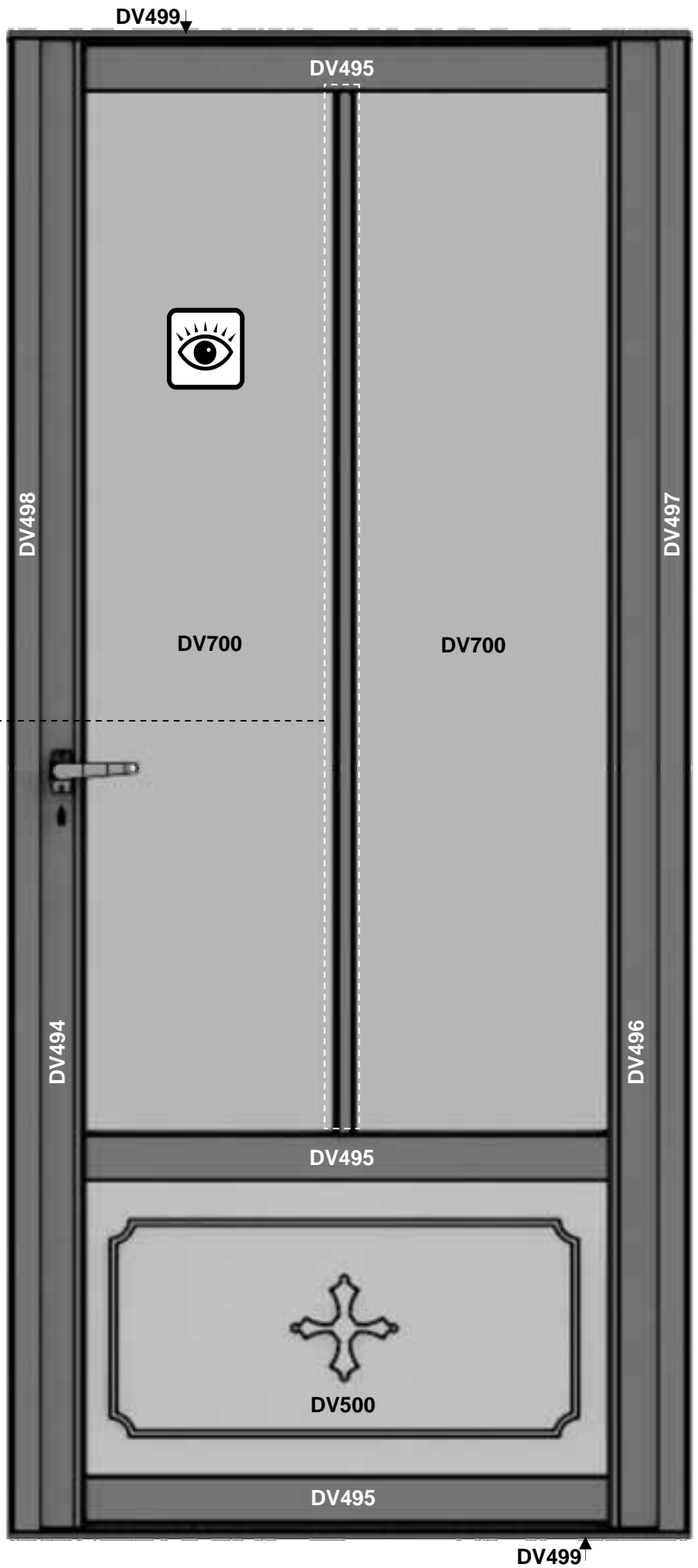
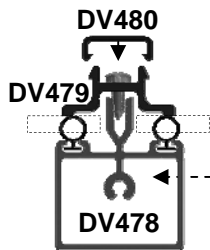
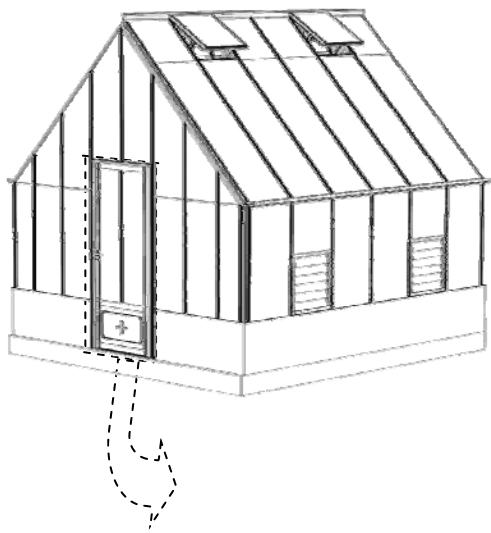

9



10

Part No		Quantity
D522		10
SYBOLM6 X11CROP		20
SYNUTM6		20

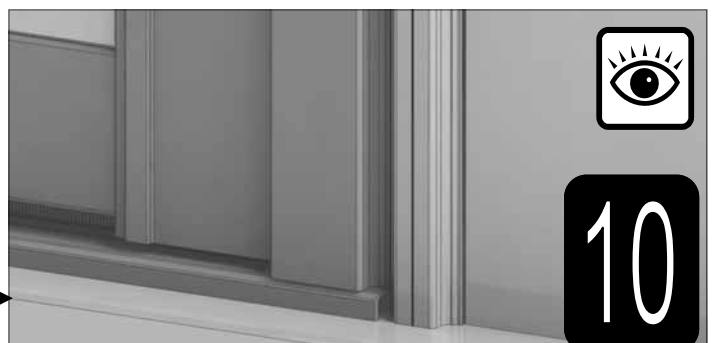
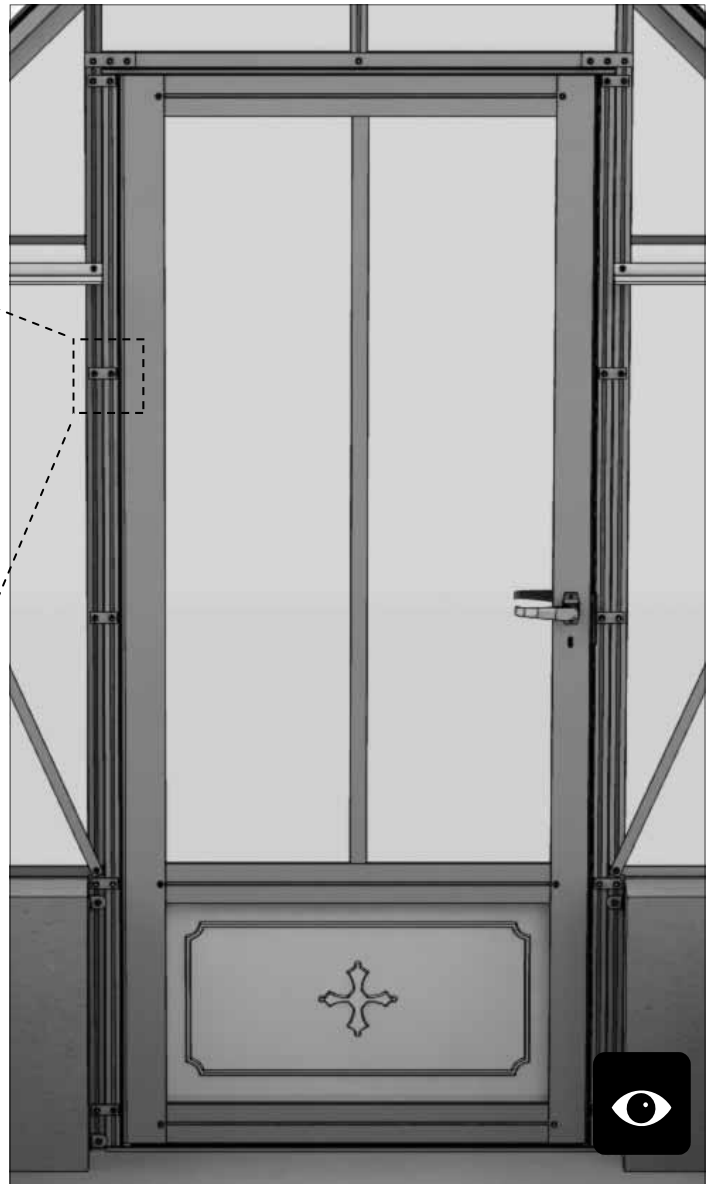
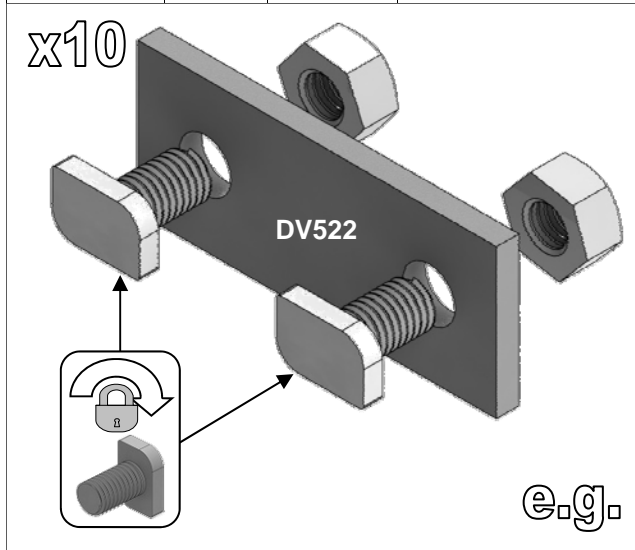

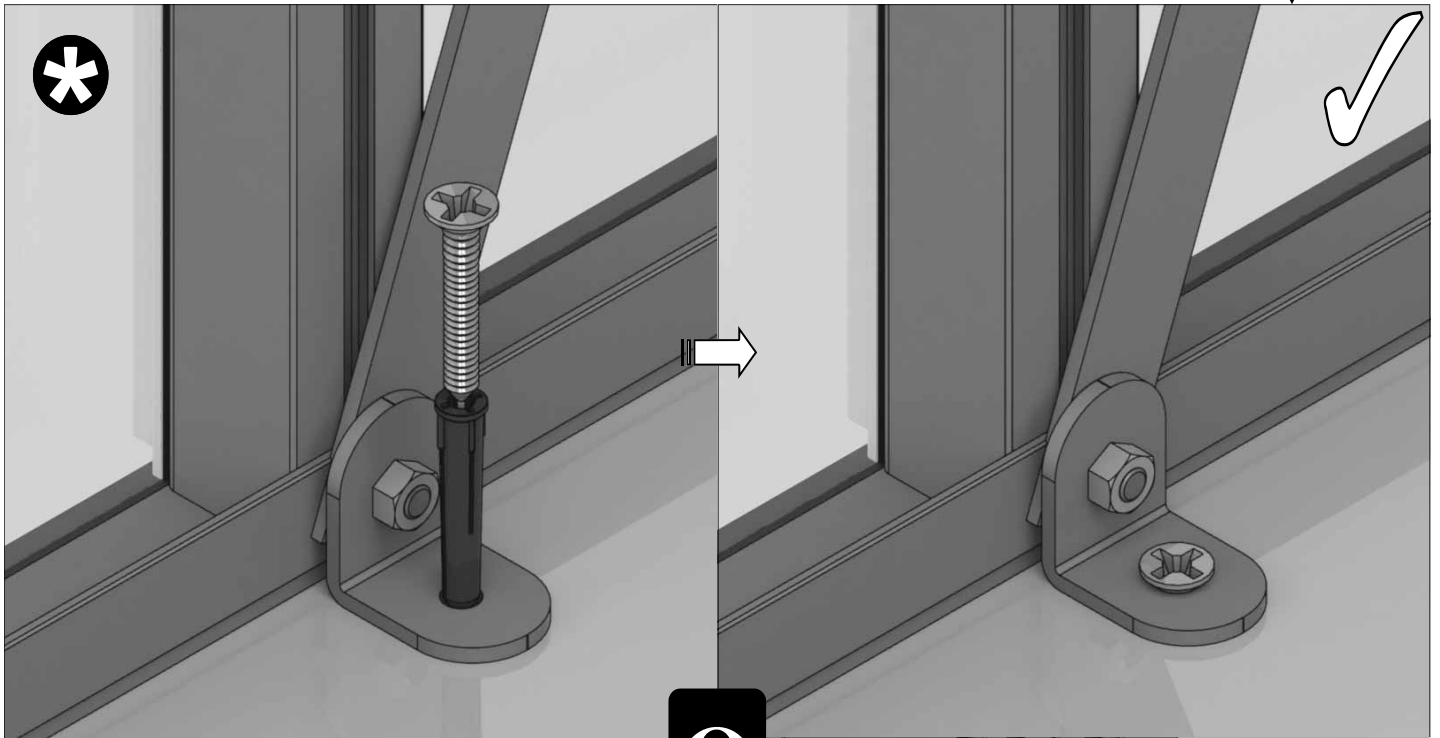
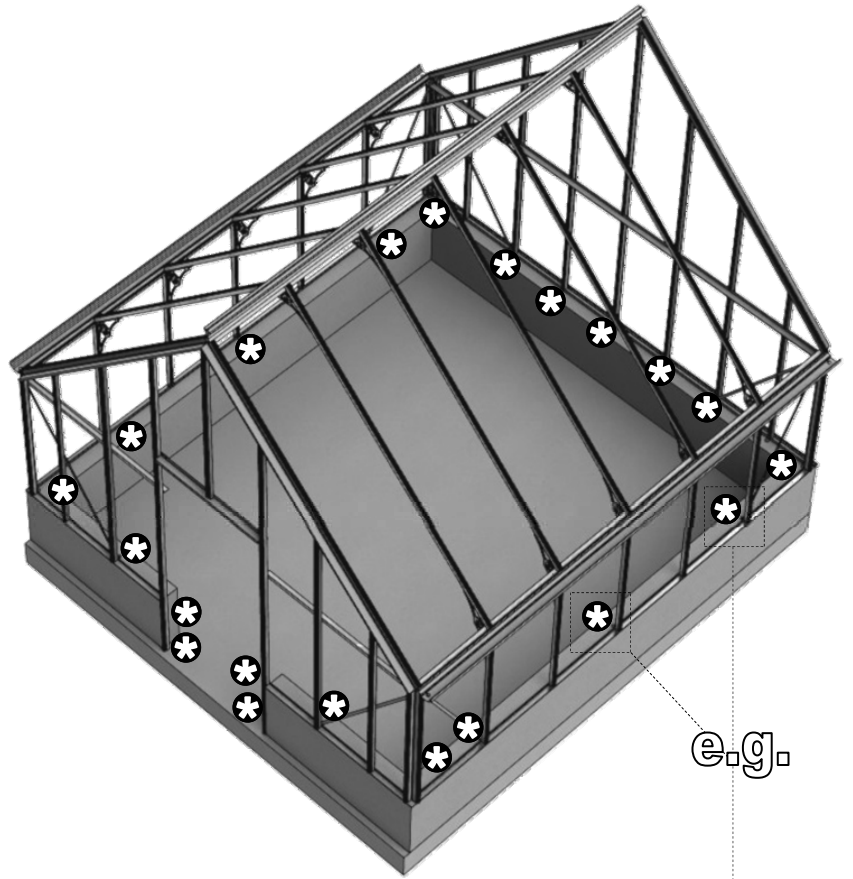
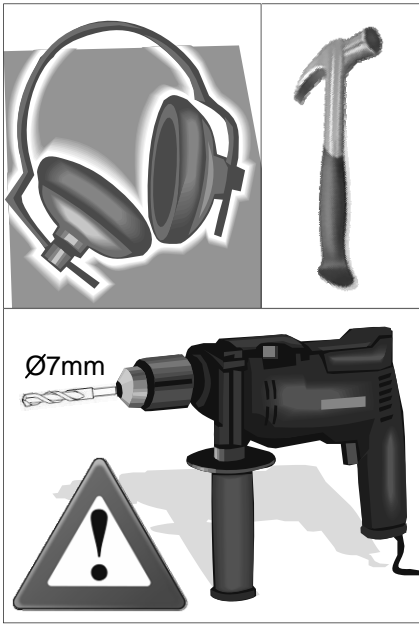

11

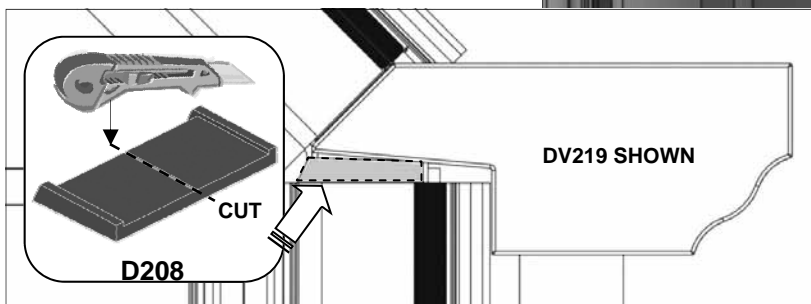
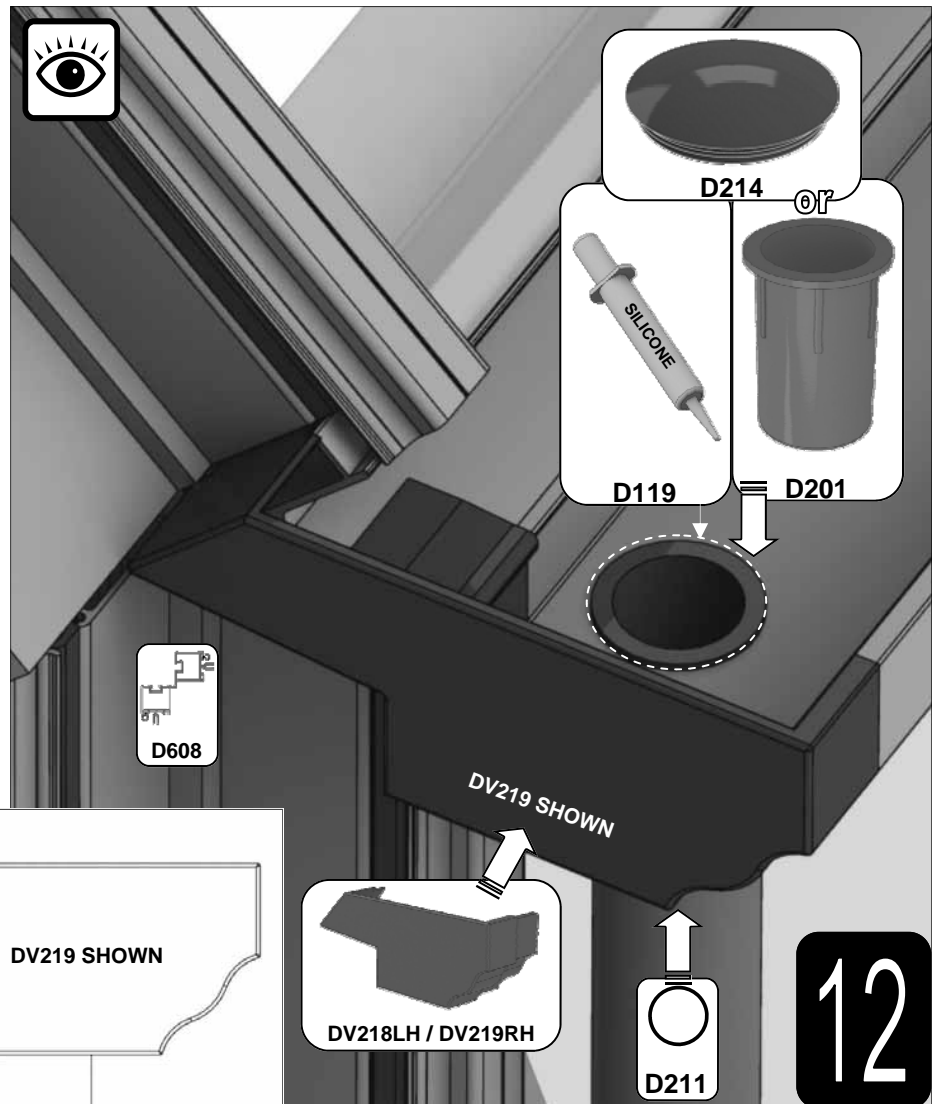
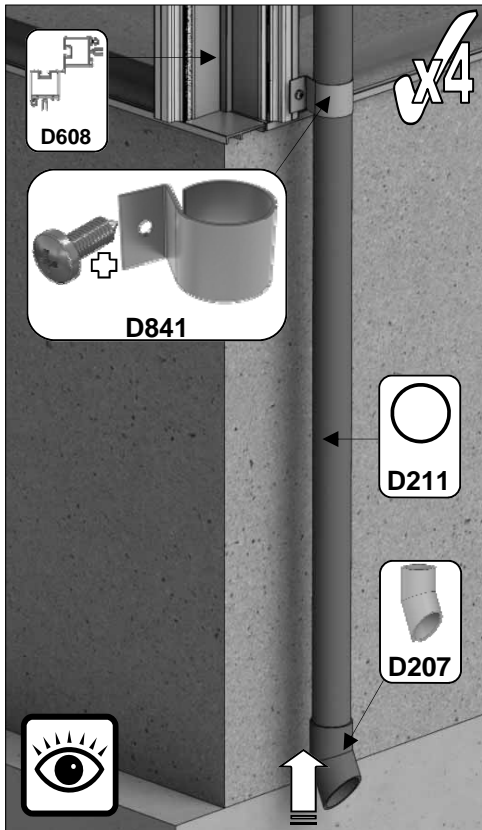
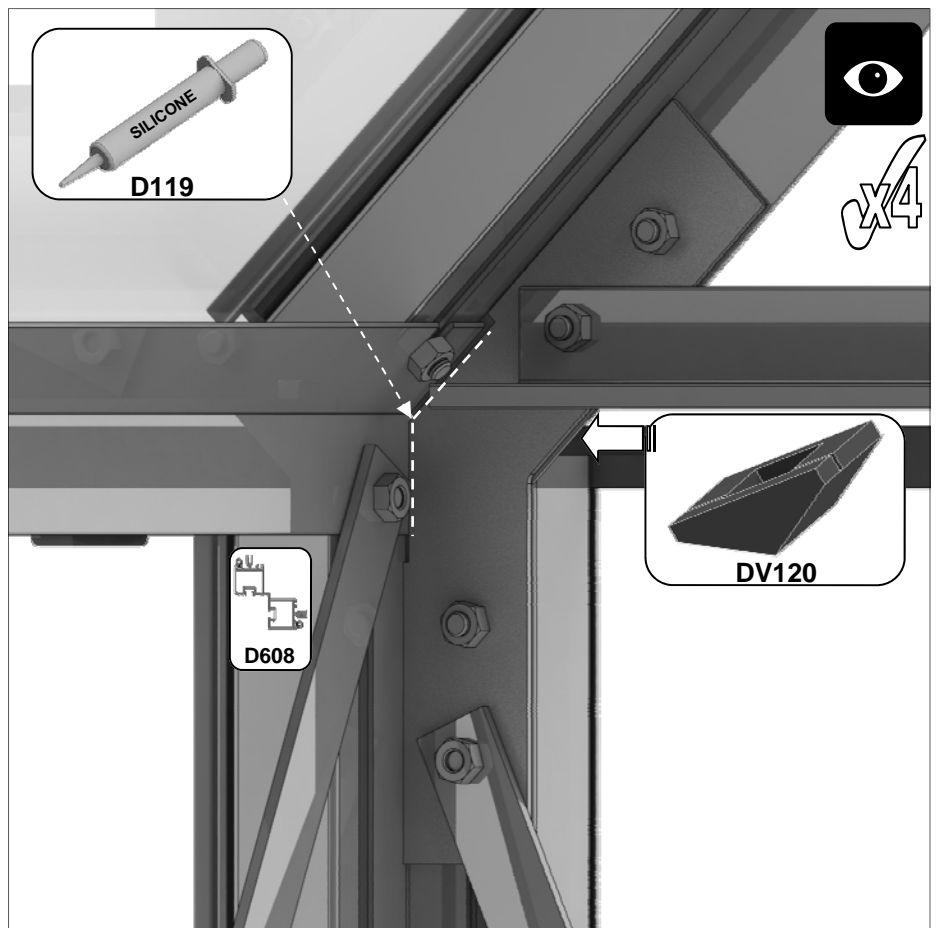
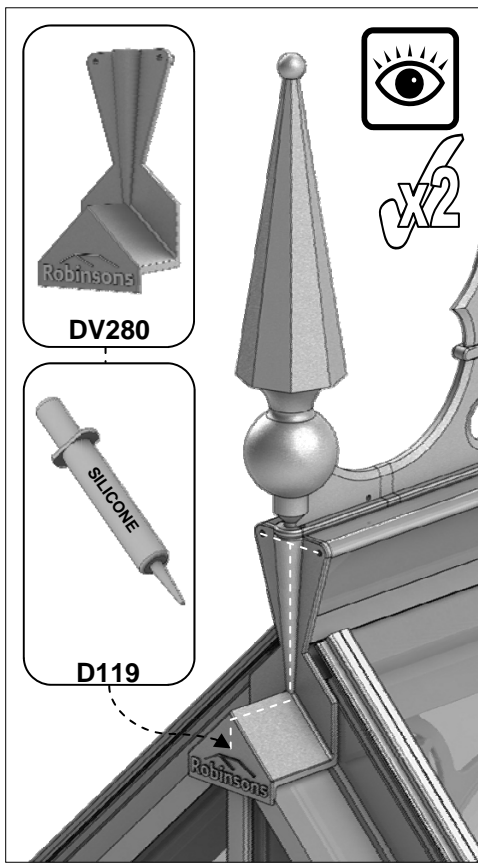

12

Example: 2x 4' 3 slat shelves 'ST0304' = 8' run

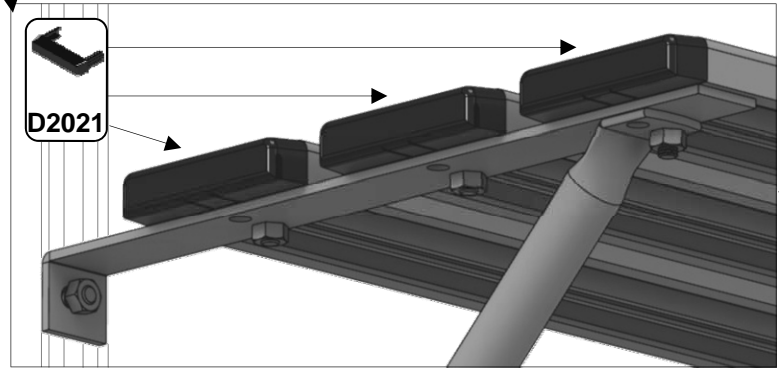
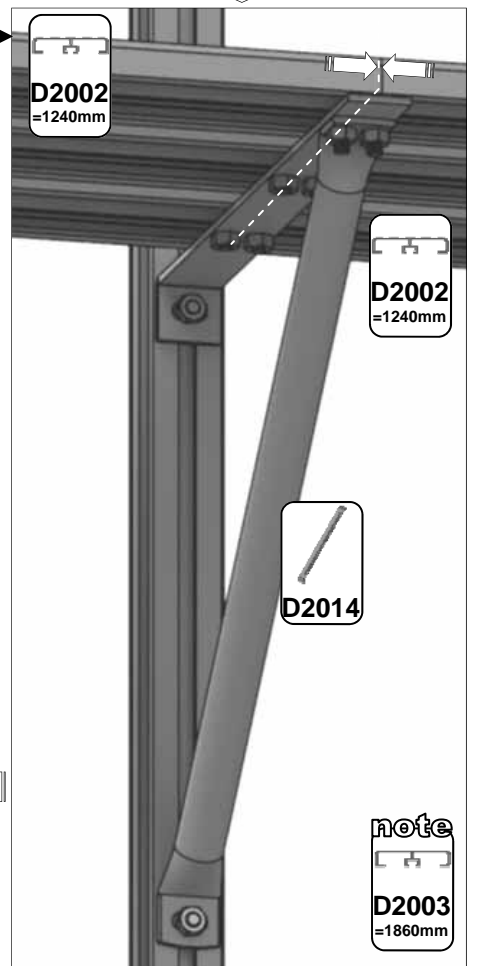
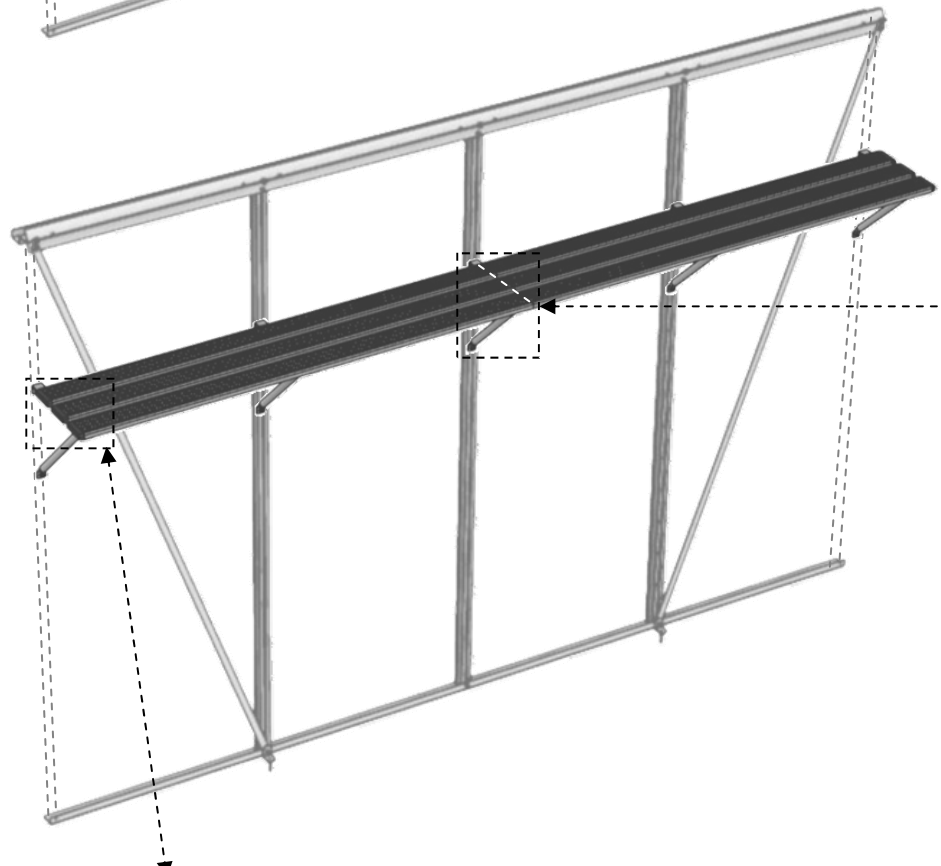
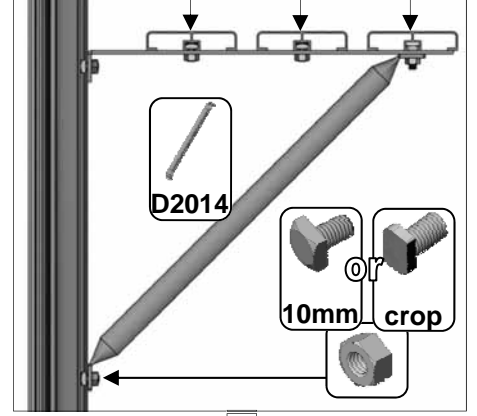
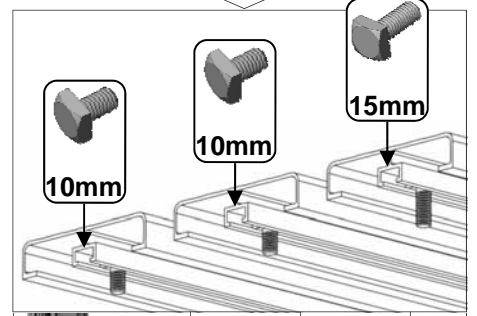
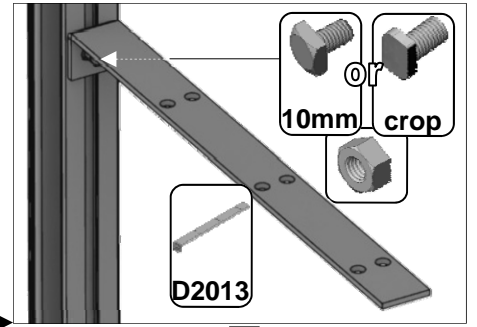
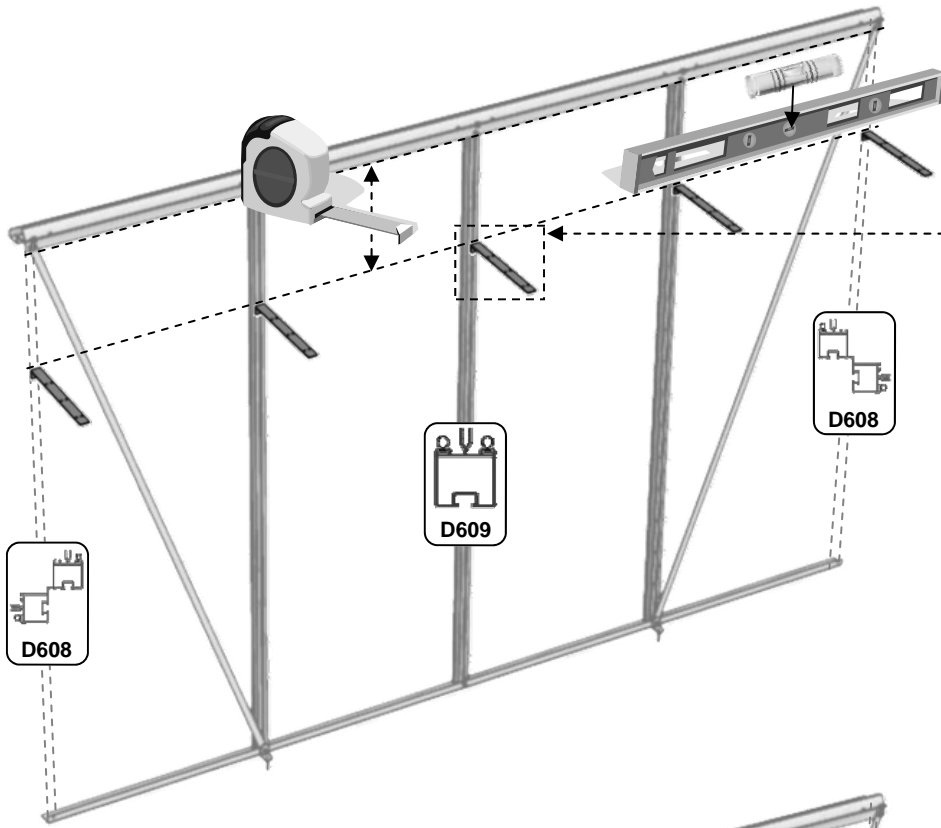

13

note
D2003 =1860mm

Example: 2x 4' 7 slat staging 'ST0704' = 8' run

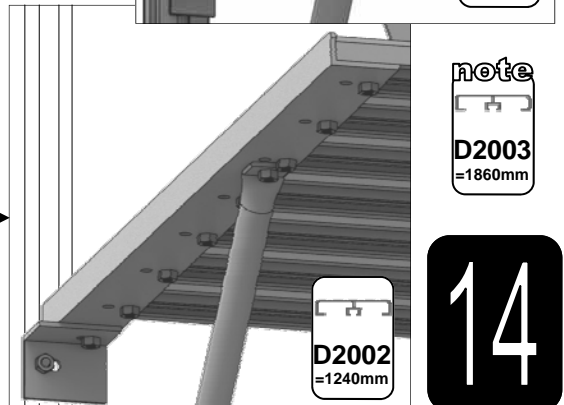
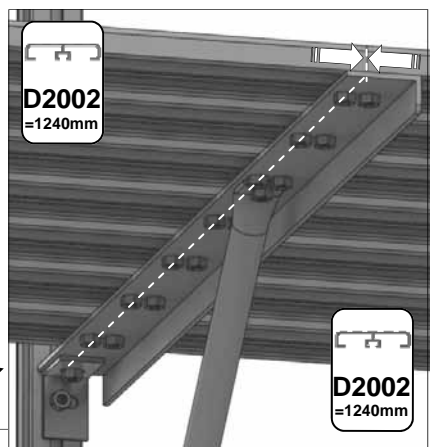
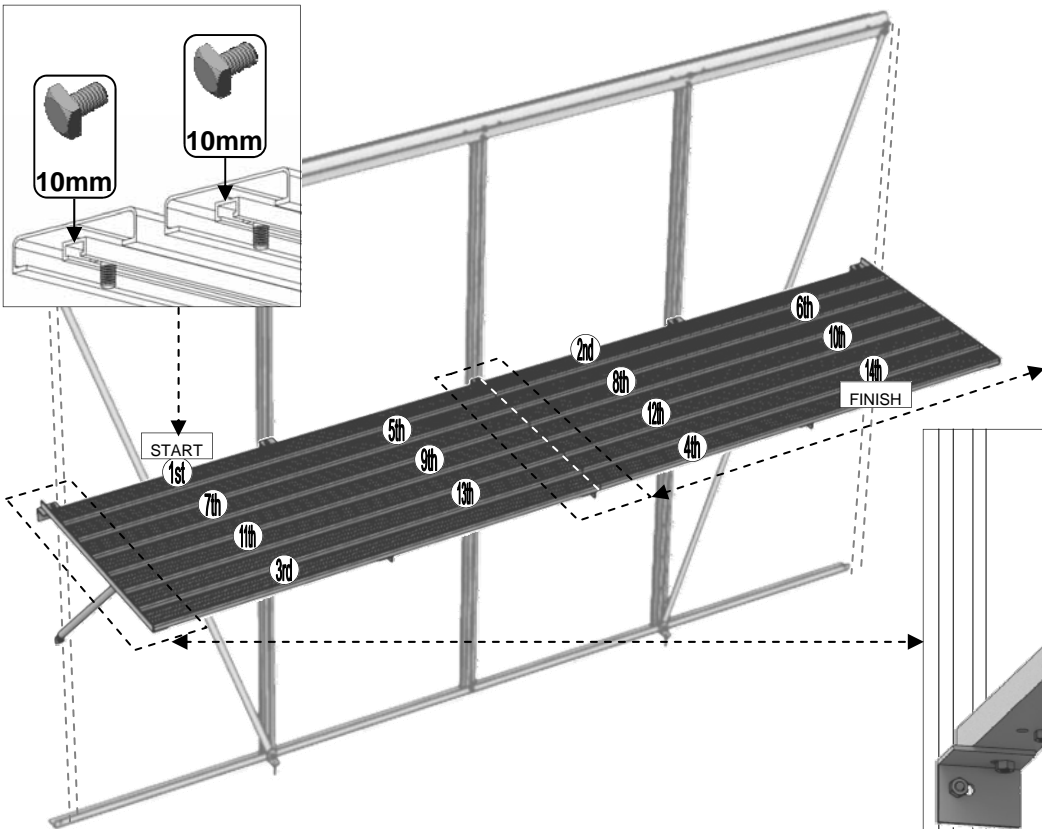
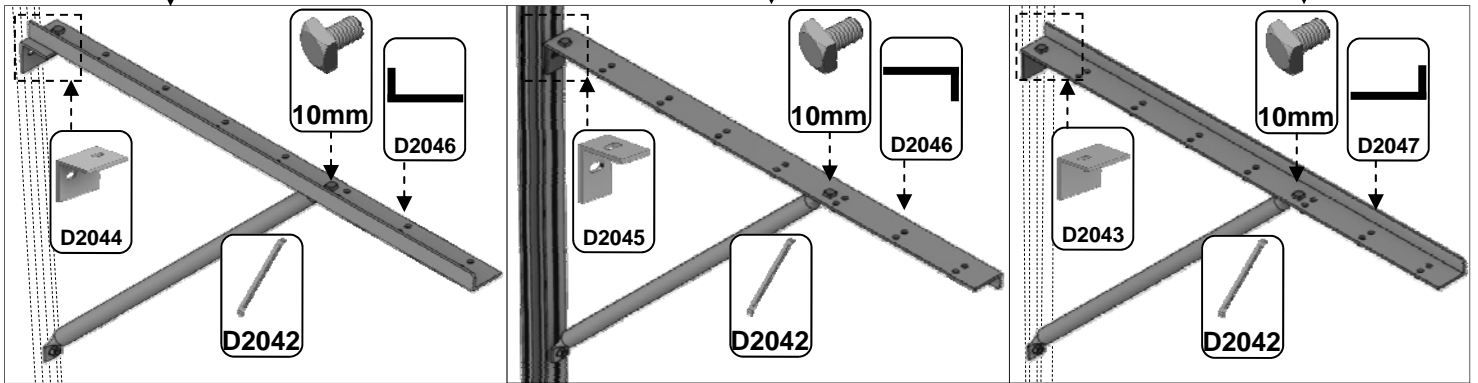
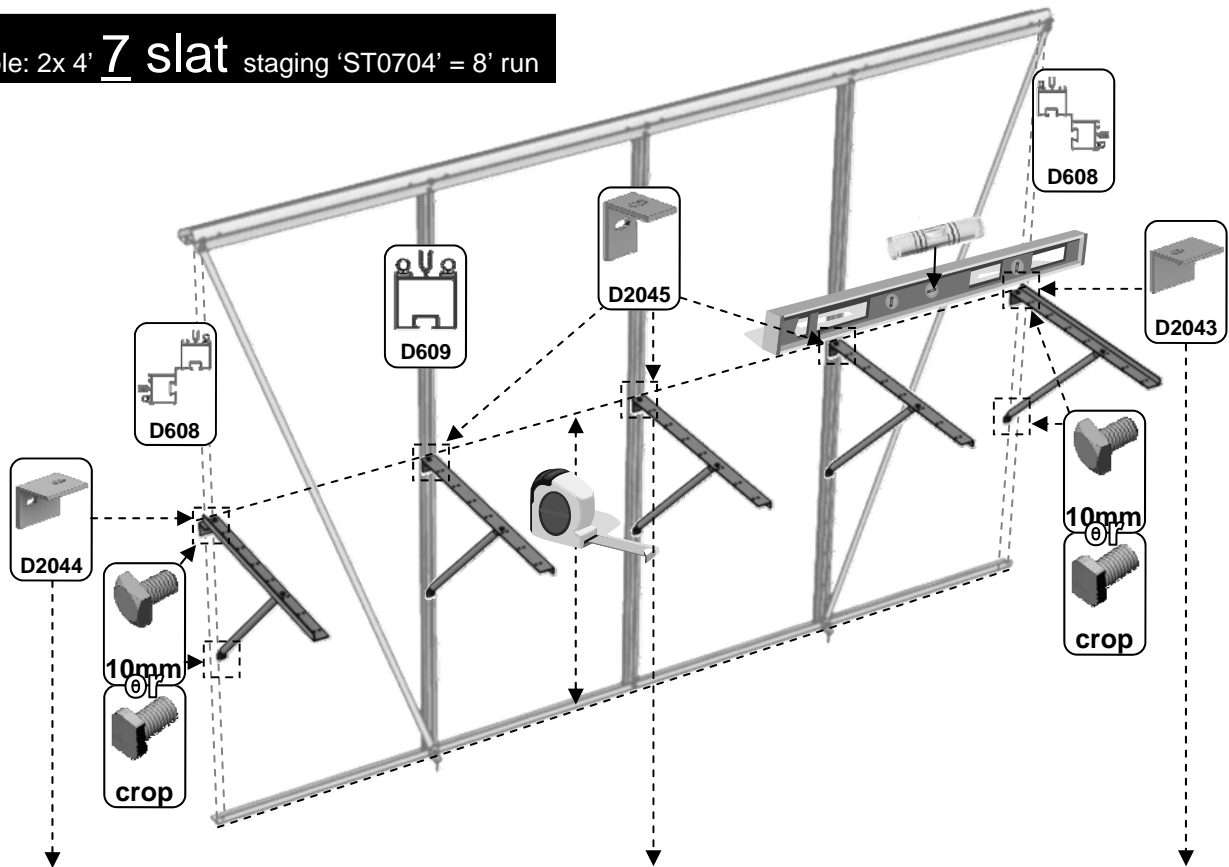

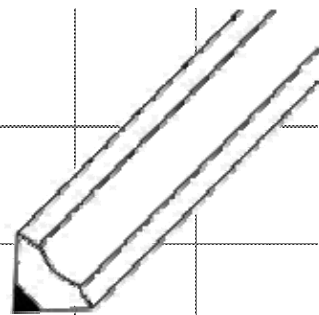

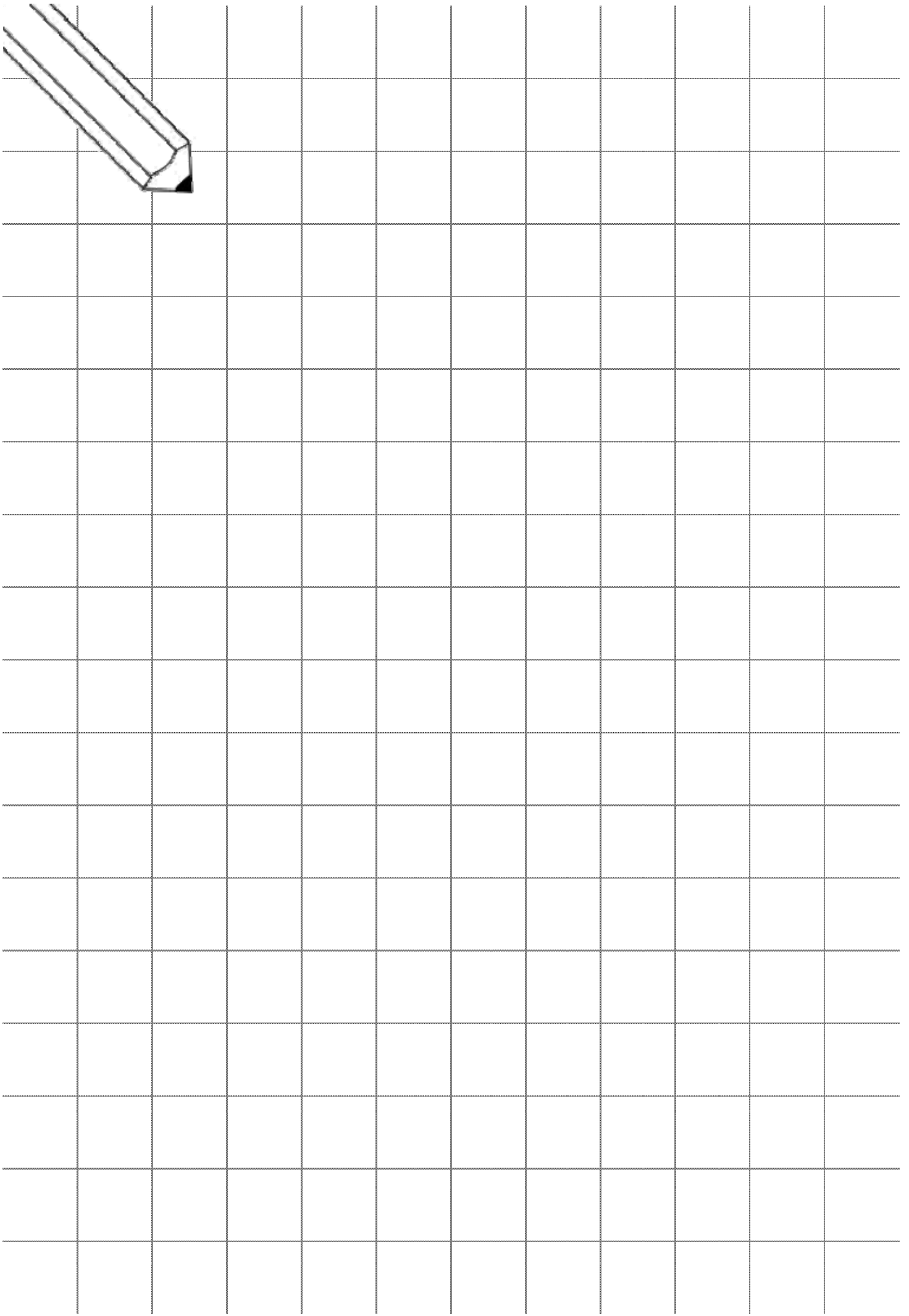
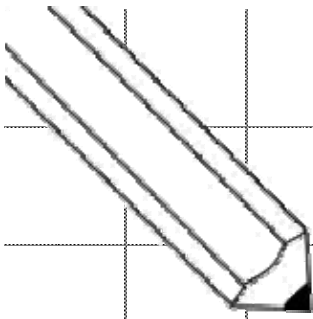

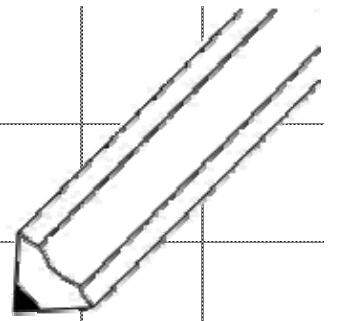

Please be aware that this is a new multi-national manual. If you spot any errors or have any constructive comments regarding the manual please email james.spooner@greenhousepeople.co.uk and I will make the necessary amendments. In addition any photographs of completed buildings would be most appreciated to add to our portfolio.

THIS GREENHOUSE BOX WAS PACKED BY: _____

DATE: _____



www.robinsonsgreenhouses.co.uk

To contact Robinsons Customer Services email us at sales@robinsonsgreenhouses.co.uk or call us on 01782 385 409.

Our address is Robinsons Greenhouses, Unit 19 Blythe Park, Cresswell, Stoke-on-Trent, Staffordshire, ST11 9RD